

A tradition of innovation since 1966

HAYBUSTER[®]

CMF-1000

[vertical mixer]



Haybuster introduces the NEW CMF-1000 Vertical Mixer! Get more capacity for maximum feeding volume!

- The new CMF-1000 has a capacity of up to 1,150 cubic feet and can hold up to 28,800 pounds of feed.
- Featuring two augers, this twin screw unit is equipped with 18-1/4 inch serrated adjustable knives, allowing the user to control the machine's aggressiveness at many levels.
- The large 24-inch by 40-inch door opening allows for quick and even unloading of all mixes.
- The redesigned 36-inch unloading conveyor can be equipped with the optional 3-foot hydraulic unloading extension and HD magnets.
- Heavy Duty Oscillating axles for even weight distribution on uneven ground.
- 24-inch (60.9cm) replaceable steel wall liner on the inside lower portion of the sidewalls.
- Unload from the right, left or both sides with the optional extension.

HAYBUSTER[®]

TUB GRINDERS

GRAIN DRILLS

ROCK PICKERS

SPECIFICATIONS

CAPACITIES:

Mixing Capacity w/o extensions	1,000cu ft(28.32cu.m)
Mixing Capacity w/12" extension	1,150cu ft (32.56 cu m)
Gross weight capacity	50,000 lbs (22,679.62kg)
Tare Weight-TMR	28,800 lbs 13,063.46kg)

AUGERS

Number	2
Diameter	88" (282.52cm)
Flighting thickness	5/8" (1.59cm)
Number/thickness-Knives	18-1/4" (.635cm)self sharpening

DOOR OPENING

24" (60.96cm) X42" (106.68cm)

SIDE WALL THICKNESS

1/4" (0.635cm)
w/24" (60.96cm) 12 gauge replaceable steel wall liner

FLOOR THICKNESS

3/4" (1.91 cm)

OBSERVATION WINDOWS

2

DRIVELINE AND GEAR BOXES

1 3/4" (4.45cm) constant velocity 1,000 rpm PTO shaft w/Two Speed Gearbox(Standard Equipment)
Protection Free Motion Automatic Clutches(2)
(2) RR USA Gear Boxes with 2 Year Warranty

UNLOADING CONVEYOR

Discharge height	36" (91.44cm) Chain w/ hydraulic orbital motors 26 5/8" (67.63cm) to 55" (139.7cm)
Discharge options	Left,Right or both. Rear Commodity door

SCALE

Digi-Star 4 point scale with Choice of Digi-Star Scale monitor

WEIGHT

Total	21,200 lbs (9,616.16kg)
Tongue Weight	2,800 lbs (1,270.06kg)

TRANSPORT DIMENSIONS

Width	132", 11ft (3.35m)
Length	308",25 ft 8 in (7.82m)
Height(w/o ext)	132",11 ft. 0 in (3.35 m)

WORKING DIMENSIONS

Loading Height w/extensions	142", 11ft 10" (3.61m)
Width	143 3/4",11ft 11" (3.65m)

CHASSIS

Towing Arrangement	V-Block or Clevis type hitch
Tires	(4) 315/80R 22.5 20 ply rated
Wheels	(4) 22.5x 9"-10 hole
Axle	Oscillating
Bearings	Tapered Roller
Jack capacity	7,000lbs (3175.2kg) 10" travel
Extensions	12" rubber

REQUIREMENTS FOR OPERATION-TRACTOR

PTO Horsepower Required	150 recommended minimum HP
PTO requirement	1,000 rpm,1 3/4" dia w/20 spline
Min. Hydraulic Output	8 gpm at 1,500 psi (46 lpm. x 10,345 kpa)
Electrical	12 VDC(Battery included)
SMV Sign and Road Lights	Standard Equipment

SPECIFICATIONS

[CMF-1000 VERTICAL MIXER]



Oscillating Heavy Duty Axles provide even weight distribution on uneven and frozen ground.

Twin 88" (282.5cm) Augers with 18 adjustable 1/4"(.635cm) thick serrated knives. Boil ring and extension are standard equipment.



CMF-1000

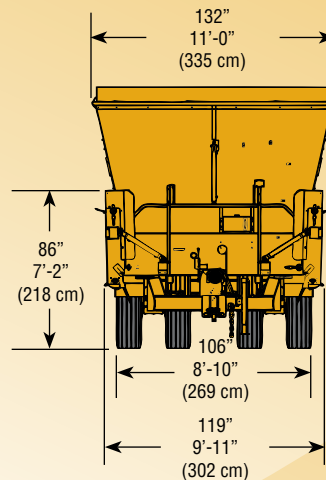
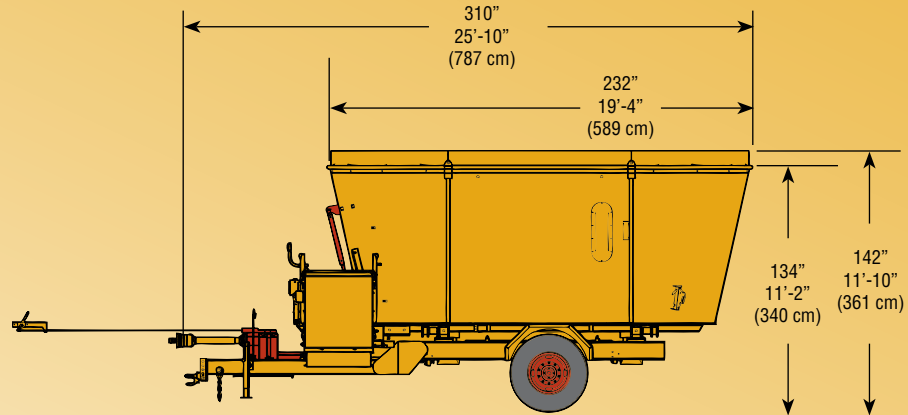

PO Box 1940
Jamestown, ND 58402-1940
Phone: (701) 252-4601
Fax: (701) 252-0502
Website: www.haybuster.com



DuraTech Industries International, Inc. reserves the right to change its products or their specifications at anytime without notice or obligation. Illustrations, specifications, and descriptions contained herein were accurate at the time of publication, but are subject to change without notice. Illustrations may include optional equipment or accessories and may not include all standard equipment.