



# CMF-700

[ cutter-mixer-feeder ]



TUB GRINDERS

GRAIN DRILLS

ROCK PICKERS

- "NEW" Vertical Mixer from Haybuster
- Cuts, mixes and feeds total mix rations in one operation
- 135 hp minimum required
- 1 3/4 in. 1000 rpm heavy duty constant velocity PTO drive line
- Drive line protection-Free motion automatic clutch
- 36 inch discharge conveyor can be set up to unload either side
- 55 inch maximum unloading height
- 700 cu. ft., 850 cu. ft. with extension
- 22,500lbs maximum feed capacity
- Digi-star 4pt scale with EZ 2000 monitor
- Heavy Duty 88 inch Twin Screw Augers, with self sharpening serrated knives, driven by 2 RR USA gear boxes with 2 year warranty
- Adjustable vertical knives for more aggressive cutting
- Rigid axles for stability in soft conditions
- Two observation windows.

[ cutter-mixer-feeder ]

# GMF-700

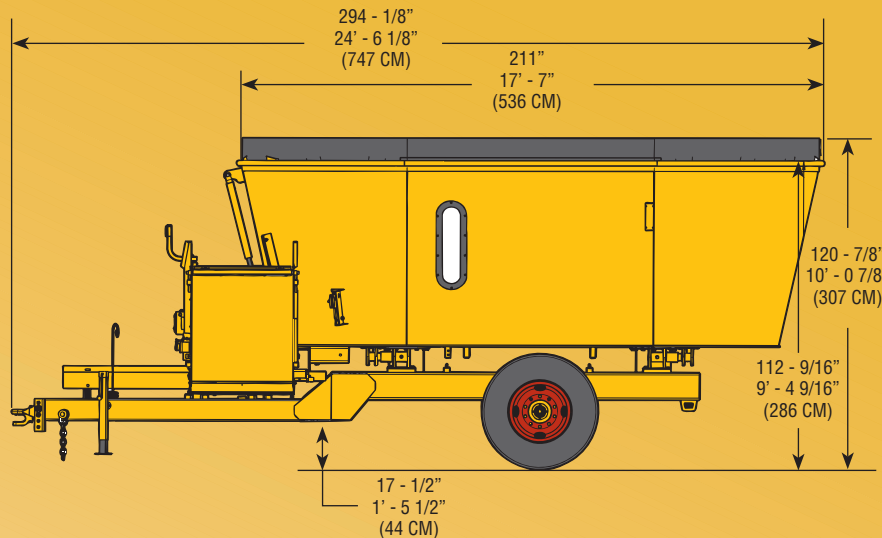
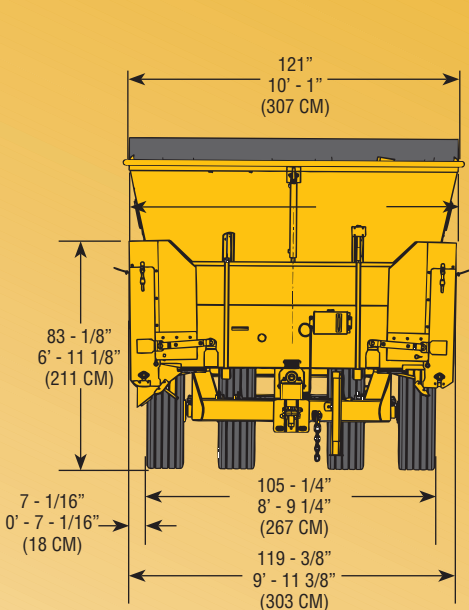

## FEATURES

### CAPACITIES

Mixing capacity w/o extensions	705cu ft (214.88 cu. m)
Mixing capacity w/ 12" extension	858 cu ft(261.52 cu m)
Gross Weight capacity	39000 lbs(17,690.1 kg)
Tare weight-TMR	21550 lbs (9,774.92kg)

### AUGERS

Number	2
Diameter	88 in ( 282.52cm)
Flighting thickness	5/8 in ( 1.59cm)
Number/thickness Knives	16 -1/4 in (.635 cm) self sharpening, serrated

### DOOR OPENING

24 in ( 60.96cm) X
42 in(106.68 cm)

### FLOOR THICKNESS

5/8 in ( 1.58 cm)
-------------------

### SIDE WALL THICKNESS

1/4 in ( 0.635 cm)
--------------------

### DRIVE LINE AND GEAR BOXES

Drive line 1 3/4 in (4.45cm) constant velocity 1000 rpm PTO
Free Motion Automatic clutch protected
Gear Boxes- 2) RR USA 100HP gear boxes, 2 year warranty pending

### SCALE

Digi-Star 4 point scale with EZ 2000 monitor
--

### OBSERVATION WINDOWS

2
---

### UNLOADING CONVEYOR

Type - 36 in ( 91.44cm) Chain
Discharge height- 26 5/8 in (67.63 cm) to 55 in (139.7cm)
Drive - Hydraulic Orbital Motor
Discharge options- Left, Right, Dual

### OPTIONS:

Discharge magnets on conveyor
Left, right or dual discharge conveyors
Rear Discharge door
2 Speed gear boxes

## SPECIFICATIONS

### WEIGHT

Total	17,400lbs. ( 7915.2kg) empty
Tongue Weight	1775lbs. (805.1 kg)

### TRANSPORT DIMENSIONS

(Fully raised conveyor)	
Width	119 3/8", 9' 11" (303cm)
Length	294 1/8", 24' 6 1/8", (747cm)
Height	120 7/8", 10' 7/8", (307cm) rubber extension 112 9/16", 9' 4", (286cm) w/o rubber extension

### WORKING DIMENSIONS

Width	143 3/4", 11' 11" (m) w/ conveyor at 45 degree angle
Loading Height	112 1/2", 9' 5" ( 2.86m) w/o rubber extension 120 7/8", 10' 7/8"(286cm) w/ rubber extension

### CHASSIS

Towing Arrangement	Clevis type hitch.
Jack Capacity	7000 lbs (3175.2 kg)
Jack Travel	10" (25.4 cm)
	Tires - 4)315/80R22.5 20ply Wheels - 4) 22.5x9-10 hole
Axle	Rigid
Bearing Type	Tapered Roller

### REQUIREMENTS FOR OPERATION

PTO Horsepower Required - 135 HP minimum
PTO Type - 1000 RPM, 1 3/4" dia PTO Shaft with 20 Splines
Min. Tractor Hydraulic Output - 8 gpm at 1500 psi (46 lpm x 10,345 kpa)

FEATURES & SPECIFICATIONS

PO Box 1940  
 Jamestown, ND 58402-1940  
 Phone: (701) 252-4601  
 Fax: (701) 252-0502  
 Website: [www.haybuster.com](http://www.haybuster.com)

*DuraTech Industries International, Inc. reserves the right to change its products or their specifications at anytime without notice or obligation. Illustrations, specifications, and descriptions contained herein were accurate at the time of publication, but are subject to change without notice. Illustrations may include optional equipment or accessories and may not include all standard equipment.*

