

HAYBUSTER

1068 DRILL

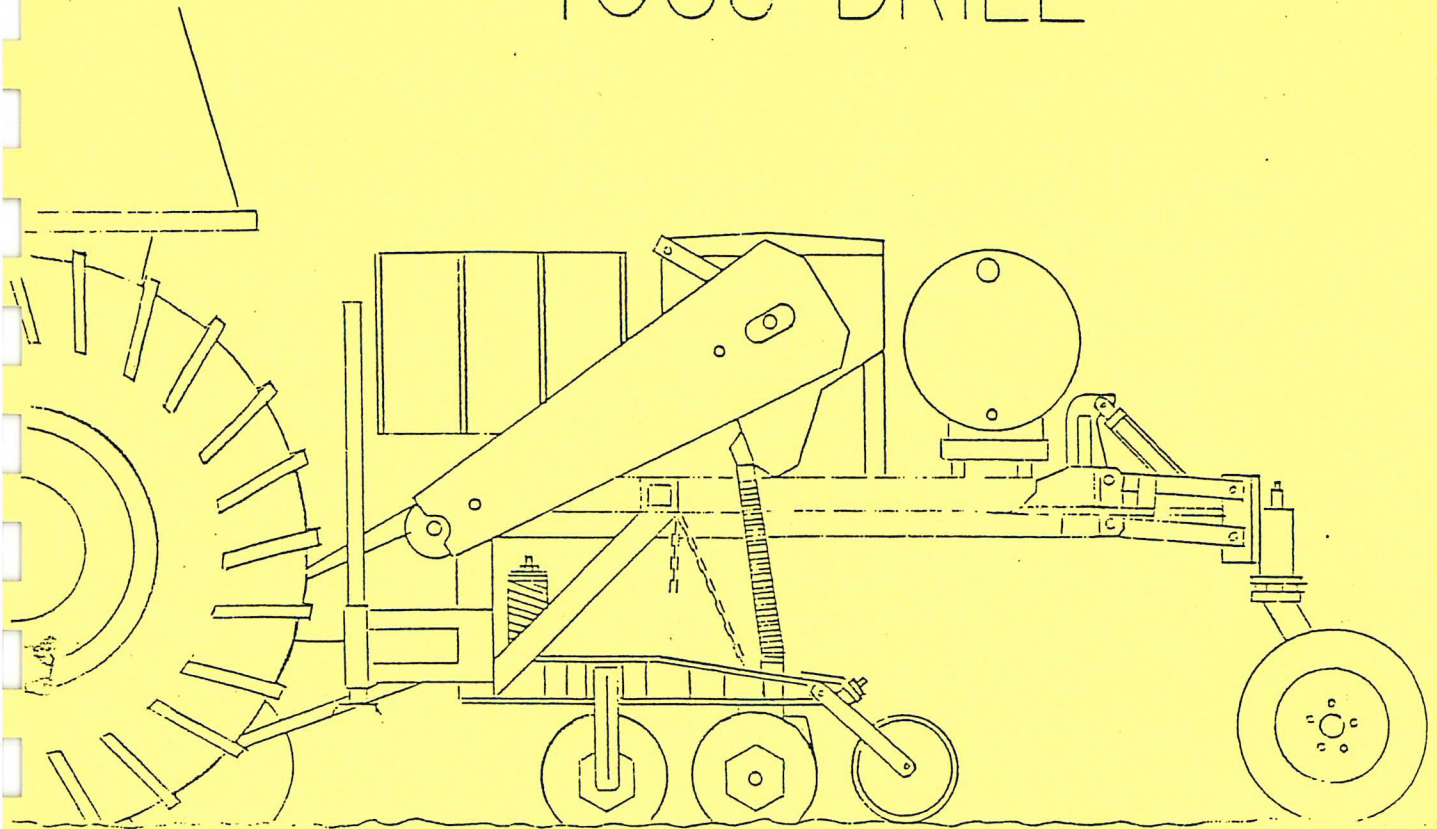

PARTS  
BOOK

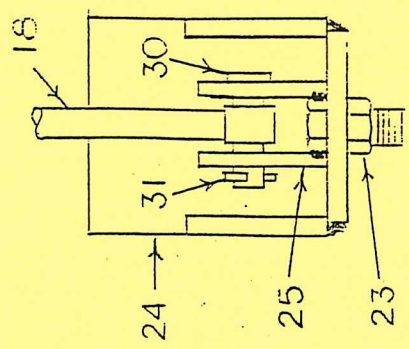
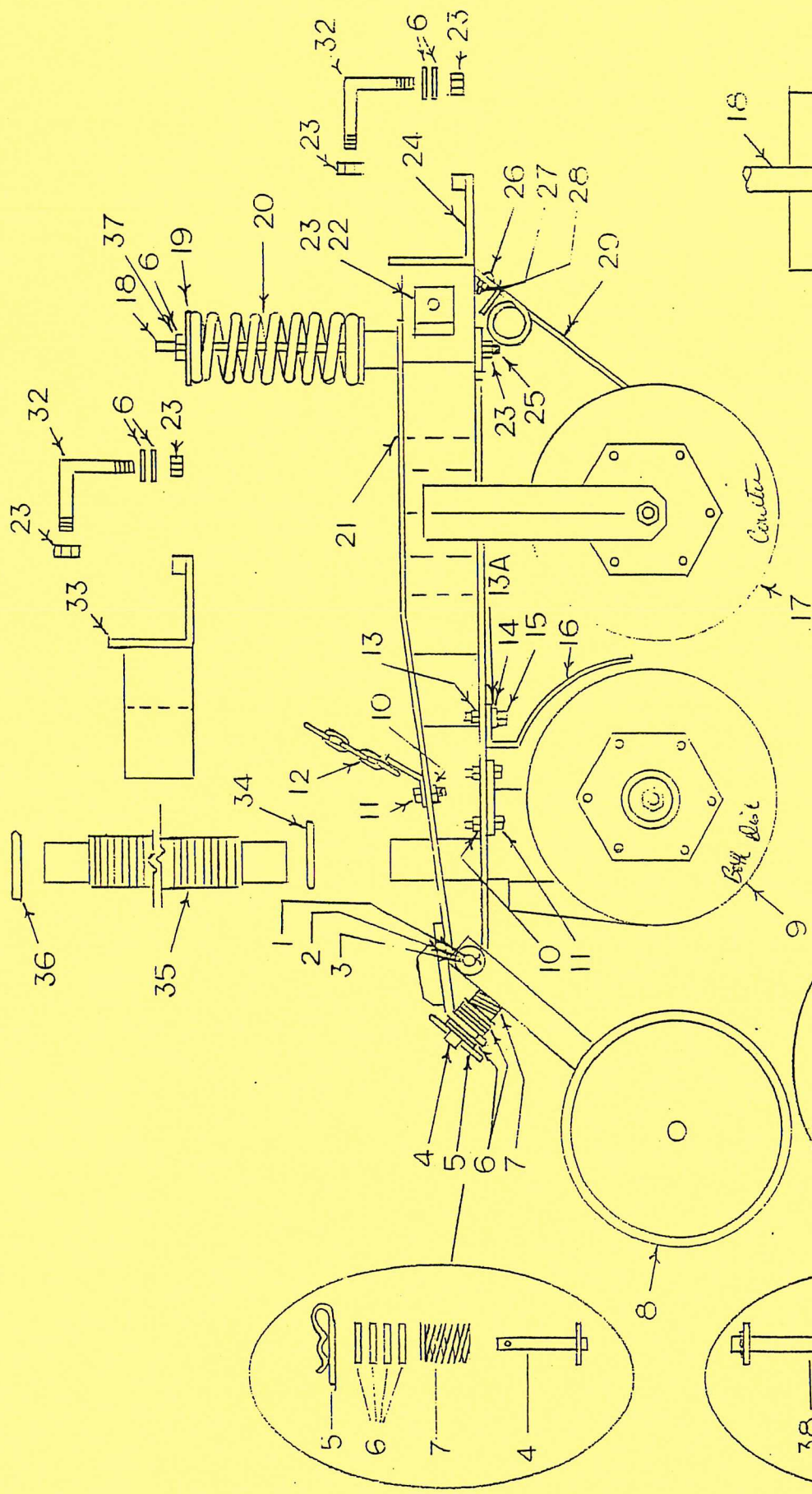

(3 Blades)  
 DOUBLE SPRING  
 DEPTH ROD ASSEMBLY

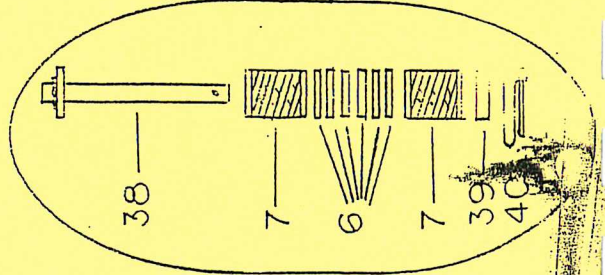
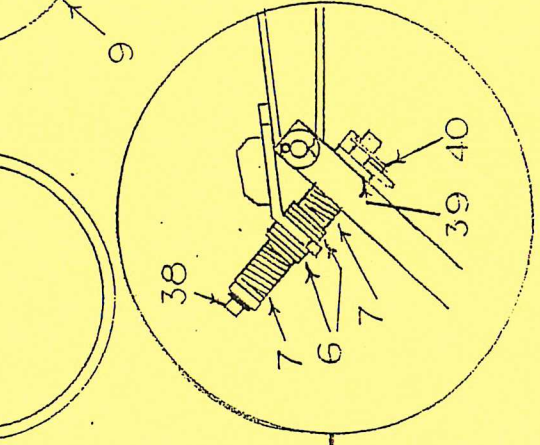
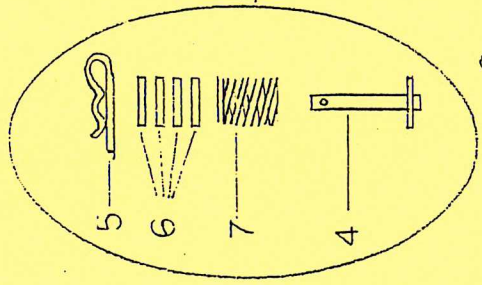

1068 DRILL PARTS BOOK

REF.	PART NO.	QTY.	DESCRIPTION
1	4800119	1	5/8 X 3 1/2 Clevis Pin Plated
2	5000002	1	5/8 Flat Washer (Double Press Wheel Only)
3	4800120	1	3/16 X 1 3/4 Cotter Key Plated
4	4800121	1	Press Wheel Depth Rod
5	4800122	1	5/16 Hair Pin
6	5000005	4	(Per Depth Rod) 3/4 Flat Washer Plated
7	6100005	1	2 3/8 Long, 1 1/2 O.D. Spring
8	2800015	1	Dual Press Wheel Assembly Optional Single Press Wheel Assembly
9	7500017	1	Disk Assembly
10	4900014	5	1/2" Crimp End Lock Nut Plated
11	4800082	5	3/8 X 1 1/2 Grade 5 Bolt Plated
12	1100101	1	Run Lift Chain
13	4900003	1	5/16 Nut Plated
13A	5000022	1	5/16 Lock Washer
14	5000023	1	5/16 Flat Washer
15	4800013	1	5/16 X 1" Bolt Plated
16	7400189	1	Boot Fender
17	7500035	1	Colter Assembly
18	7400190	1	Spring Rod, 15" Long
19	7400191	1	Spring Rod Cap, 7/8" Hole
20	6100021	1	Spring 3 1/2" X 9 1/2"
21	7400192	1	Run
22	7400193	1	Run Hinge Pin, 3/4 X 6 3/4 O.A. 6" useable
23	4900013	4	(Per Short Run) 3/4 Crimped End Lock Plated
		6	(Per Stagger)
24	7400194	1	Run Hinge Block
25	7400195	1	Spring Rod Anchor
26	4800053	1	3/8 X 1" Plated Carriage Bolt
27	5000019	1	3/8 Lock Washer
28	4900002	1	3/8 Hex Nut Plated
29	6100026	1	Trash Spring
30	4800004	1	5/8 X 2 Clevis Pin
31	4800123	1	1/8 X 1 1/2 Cotter Pin
32	4800116	1	(Per Short Run) L Bolt, 3/4" Dia. X 4 1/2" X 4 1/2"
		1	(Per Stagger Run)
33	7400196	1	(Per Stagger Run) Spacer Blocks
34	7500009	1	Hose Clamp Lower A-30
35	7500036	1	Convolutd Hose, 2" I.D. on large end
36	7500037	1	Hose Clamp, Upper A-42
37	4900004	1	3/4" Nut Plated
38	7400255	1	3/4" x 7 1/2" pin
39	5000030	1	3/4" flat washer 1/4" thick
40	7500044	1	5/16" klik pin

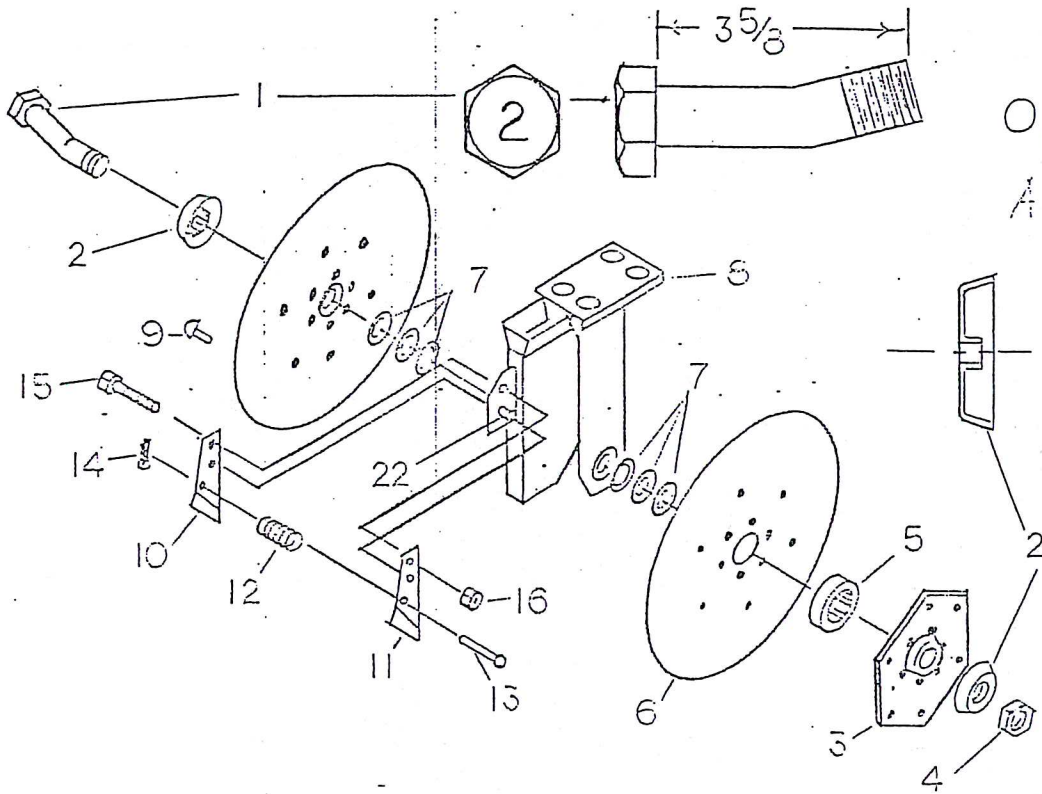

Operator Disk  
ANS End

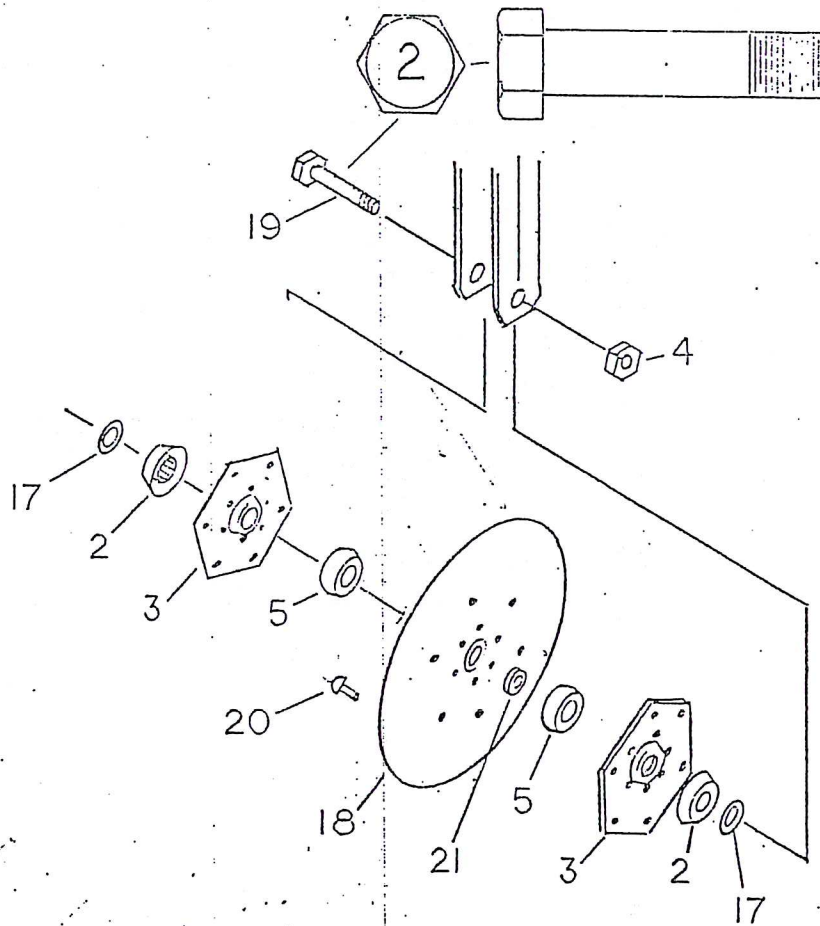

Cutting Colter

106<sup>R</sup> DRILL PARTS BOOKS

REF.	PART NO.	QTY.	DESCRIPTION
1	4 <sup>R</sup> 00036	1	Bolt #2 5/8 x 3 5/8" Bent
2	7400071	4	Cap W/Brg. Pilot
3	7400072	4	Bearing Cage 12 Rivet
4	4900012	2	5/8 Crimped Lock Nut Plated
5	2000004	4	Bearing 3/4"
6	7500010	2	14" Disk 12 Rivet
7	5000009	6	Shim Washer 1" O.D. x 5/8" ID x .030
8	7400228	1	Boot
9	4 <sup>R</sup> 00039	24	Rivet 1/4 x 1/2 Rd. Head
10	7400178	1	Scraper Left Hand
11	7400177	1	Scraper Right Hand
12	6100023	1	Spring 1/2 x 1"
13	4 <sup>R</sup> 00111	1	Clevis Pin 5/16" x 1 3/8"
14	4 <sup>R</sup> 00110	1	Cotter Pin 1/8" x 3/4"
15	4 <sup>R</sup> 00071	1	Bolt 5/16 x 1 1/4 Plated
16	4900006	1	5/16 Nylon Insert Lock Nut
17	5000002	2	5/8 Flat Washer
18	<del>7500042</del>	1	<del>14" Colter IP 24-6027 75-64</del>
19	4 <sup>R</sup> 00133	1	5/8 x 3 5/8 Bolt #2 on Head
20	4 <sup>R</sup> 00132	12	Rivet 1/2 x 7/8 Rd. Head
21	5000026	1	Preload Washer 13/16 ID x 1 1/4 OD x .138"
22	4800112	1	7/16 x 1 1/2 Plated Rolled Pin
23	4800153	6	1/2" X 1 1/4" Button Head
24	4900014	6	1/2" Lock Nut
25	5000006	6	1/2" Lock Washer
26	5000016	6	7/16" Flat Washer
3A	<del>8400054</del> 7400257	2	Bolt on BRG Cage
18A	7500064	1	14" Coulter Disk ( 6 hole)

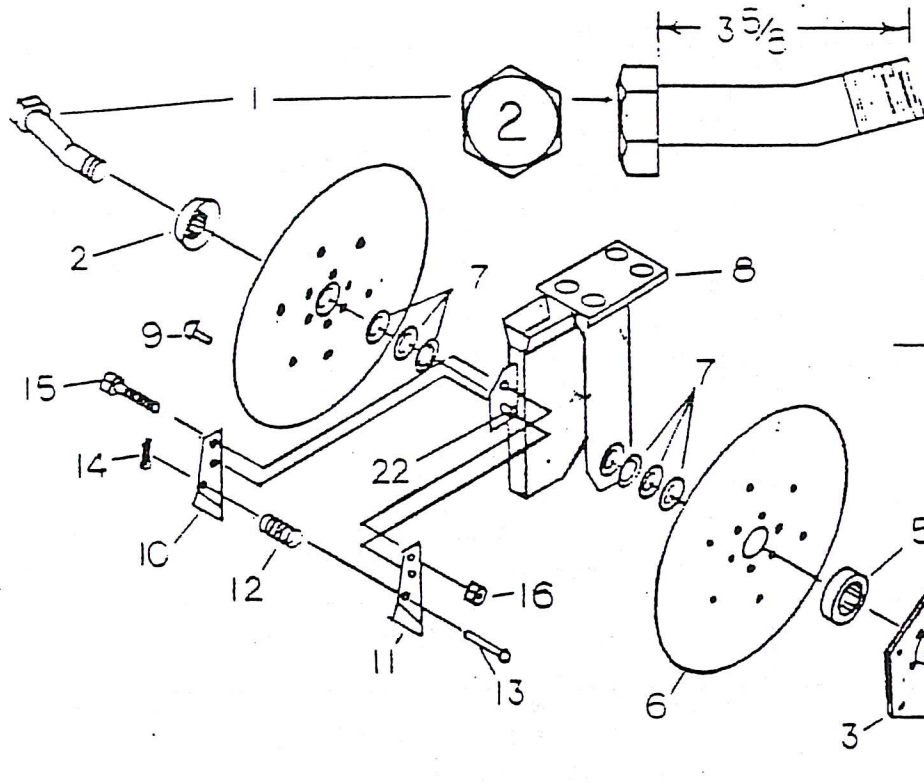

Control Unit  
 And Base

84-93

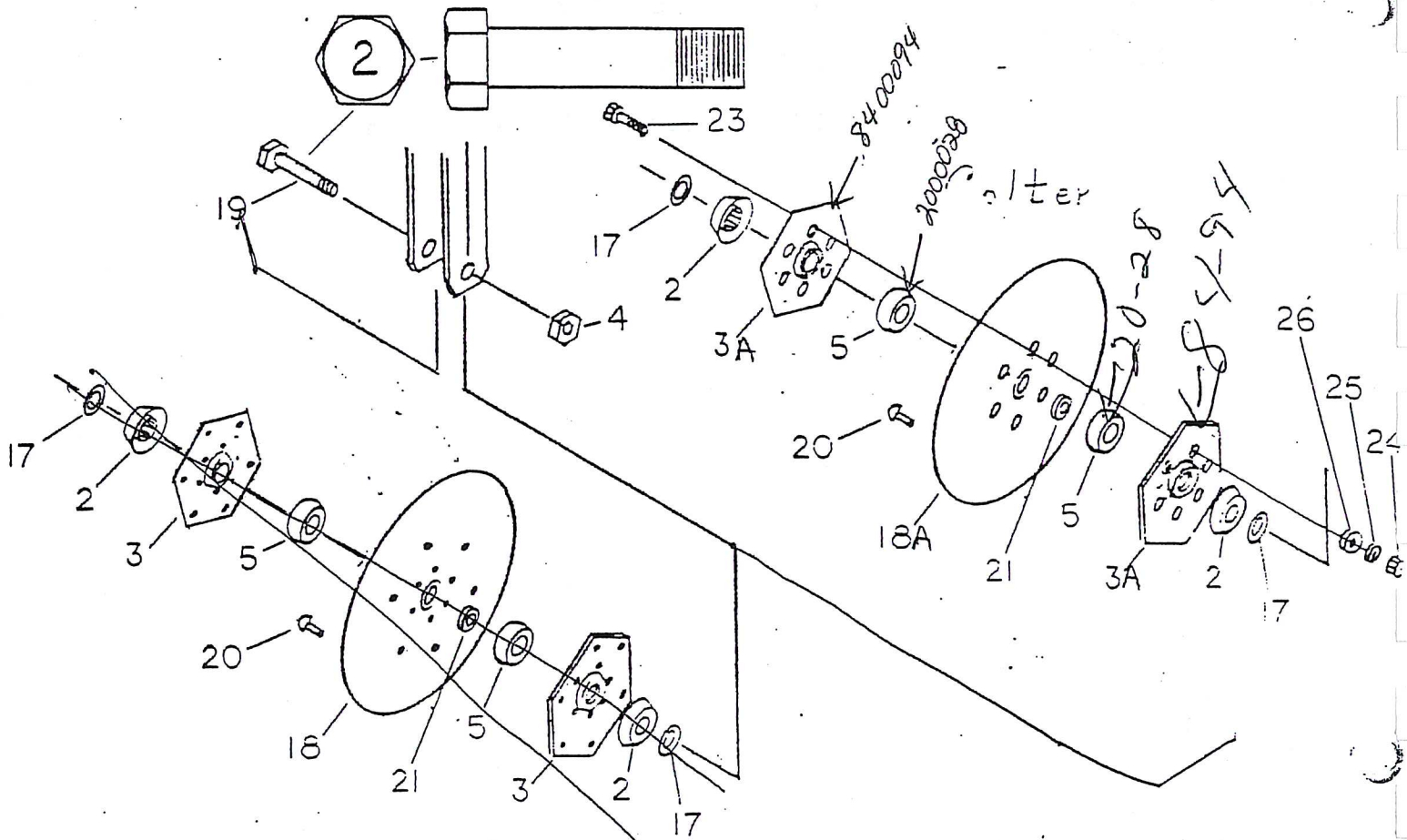

1068 DRILL PARTS BOOKS

REF.	PART NO.	QTY.	DESCRIPTION
1	4200035	1	Bolt #2 5/8 x 3 5/8" Bent
2	7400071 <del>258</del>	4	Cap W/Brg. Pilot
3	7400072	4	Bearing Cage 12 Rivet
4	4900012	2	5/8 Crimped Lock Nut Plated
5	2000004 <del>28</del>	4	Bearing 3/4"
6	7500010 <del>64</del>	2	14" Disk 12 Rivet
7	5000009	6	Shim Washer 1" O.D. x 5/8" ID x .030
8	7400222	1	Boot
9	4200039	24	Rivet 1/4 x 1/2 Rd. Head
10	7400172	1	Scraper Left Hand
11	7400177	1	Scraper Right Hand
12	6100023	1	Spring 1/2 x 1"
13	4200111	1	Clevis Pin 5/16" x 1 3/8"
14	4200110	1	Cotter Pin 1/8" x 3/4"
15	4200071	1	Bolt 5/16 x 1 1/2 Plated
16	4900006	1	5/16 Nylon Insert Lock Nut
17	5000002	2	5/8 Flat Washer
18	7500042	1	14" Colter IP 24-6027
19	4200133	1	5/8 x 3 5/8 Bolt #2 on Head
20	4200132 <del>275</del> <del>226</del>	1	Rivet 1/2 x 7/8 Rd. Head
21	5000026	1	Preload Washer 13/16 ID x 1 1/4 OD x .138"
22	4200112	1	7/16 x 1 1/2 Plated Rolled Pin
23	4800153	6	1/2" X 1 1/4" Button Head
24	4900014	6	1/2" Lock Nut
25	5000006	6	1/2" Lock Washer
26	5000016	6	5/8-18 Flat Washer
3A	<del>8400057</del> <del>7400257</del> <del>94</del>	2	Bolt on BRG Cage
18A	7500064	1	14" Coulter Disk ( 6 hole)

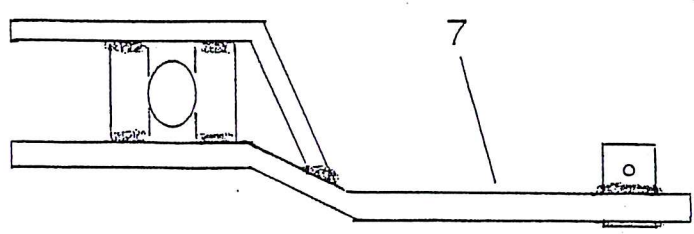
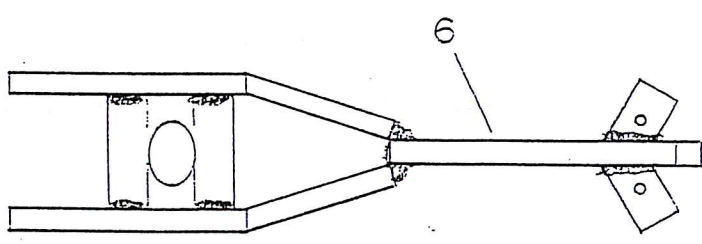
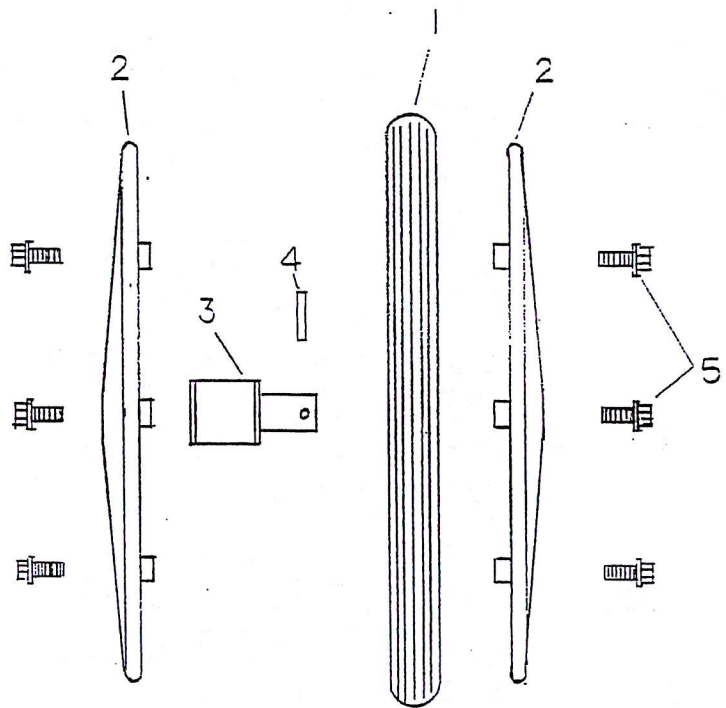



- 1068 DRILL PARTS BOOK

REF.	PART NO.	QTY/PER	DESCRIPTION
1	2600011	1	1" X 12" Rubber Tire
2	2800014	2	12" Cast Wheel Halves
3	2000024	1	Water Pump Bearing (1E07032)
4	4800131	1	$\frac{1}{2}$ " X 1" Rolled Pin
5	4800113	6	$\frac{3}{4}$ " X $\frac{3}{4}$ " Self Tapping Flange Bolt
6	7400226	1	Press Wheel Hanger (For 2 press wheels)
Option			
7	7400227	1	Press Wheel Hanger (For 1 press wheel)

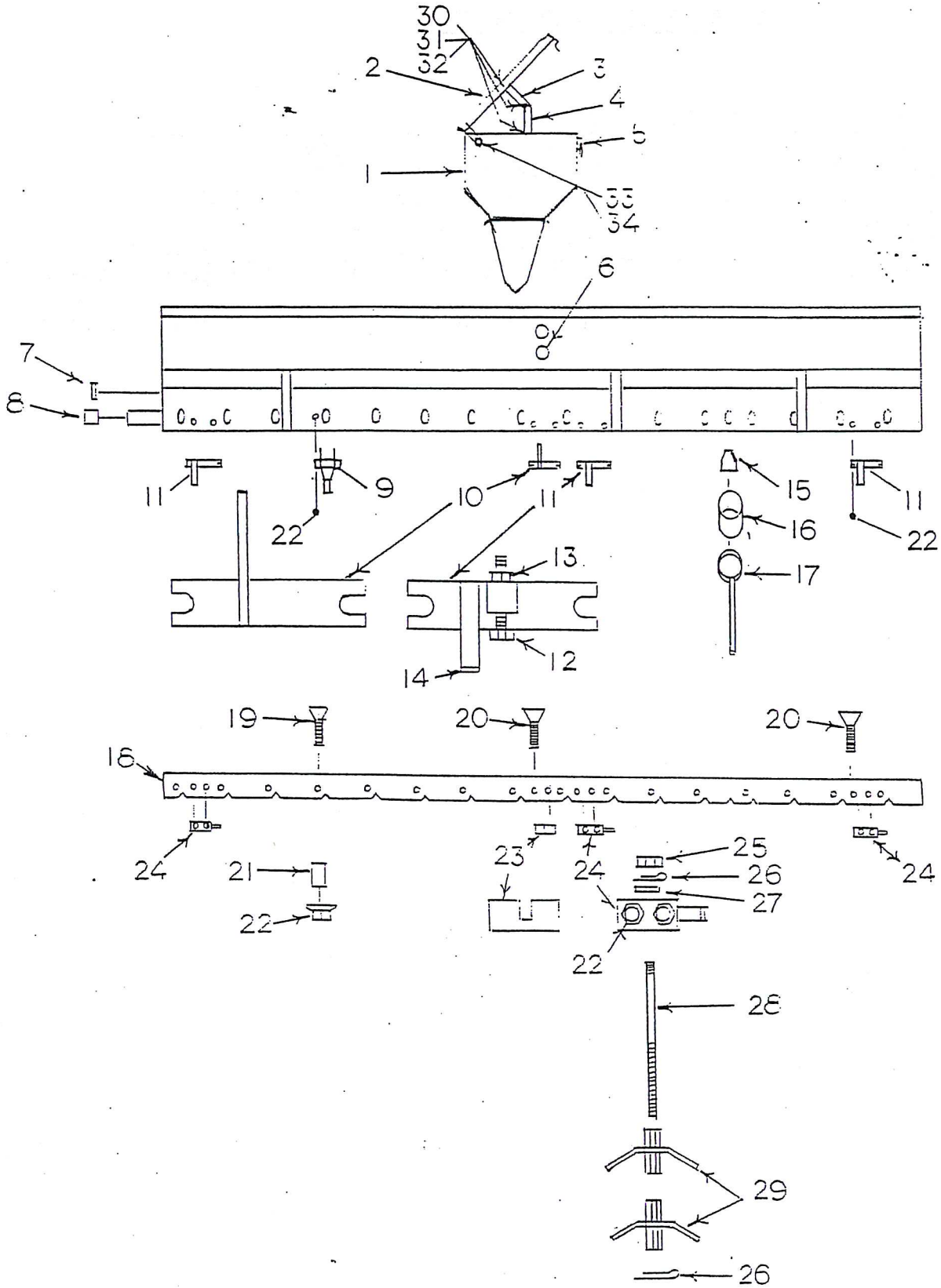

106<sup>o</sup> DRILL PARTS BOOKS

PTP:	PART NO.	QTY.	DESCRIPTION
1	7400197	1	Train Tank
2	740019 <sup>a</sup>	1	Train Tank Cover
3	7400199	2	Cover Holder-Upper
4	7400200	2	Cover Holder-Lower
5	750003 <sup>a</sup>	1	Cover Latch
6	7500039	2	Window
7	66000 <sup>a</sup> 0	1	Hole Plug
8	7500040	1	Auger Tube Cap-2" Pipe Thread
9	7400201	16	Feed Cups
10	7400202	1	Control Plate Guide
11	7400203	3	Control Plate Stop
12	4 <sup>a</sup> 00136	3	Control Plate Stop Screw
13	4900002	3	3/ <sup>a</sup> Nut
14	7400204	3	Nylon Bushing
15	7400205	1	Calibrator Cover
16	7500041	1	Calibrator Cup
17	7400206	1	Calibrator Cup Support
1 <sup>a</sup> 8	7400207	1	Control Plate
19	4 <sup>a</sup> 00124	17	5/16 x 1 $\frac{1}{2}$ Socket Head Plated Screw
20	4 <sup>a</sup> 00125	8	5/16 x 1 $\frac{1}{2}$ Socket Head Plated Screw
21	740020 <sup>a</sup> 8	17	Spring Anchor
22	4900027	59	5/16 Flange Nut M.F #22LFL5161 <sup>a</sup>
23	7400209	1	Control Plate Guide Block
24	7400210	3	Control Plate Fork Block
25	490002 <sup>a</sup> 9	3	3/ <sup>a</sup> Fine Thread Nut
26	4 <sup>a</sup> 00126	6	3/32 x 3/4 Cotter Key
27	4900029	3	3/ <sup>a</sup> " Fine Thread Weld Nut
28	7400211	3	Control Plate Operating Rod
29	7400312	6	Control Rod Locks
30	4 <sup>a</sup> 0009 <sup>a</sup>	6	3/ <sup>a</sup> x 1 $\frac{1}{2}$ Bolts
31	5000019	6	3/ <sup>a</sup> x Lock Washer
32	4900030	6	3/ <sup>a</sup> Nylon Nut
33	4 <sup>a</sup> 0012 <sup>a</sup> 9	2	$\frac{1}{2}$ x 1" Clevis Pin
34	4 <sup>a</sup> 00127	2	Cotter Key

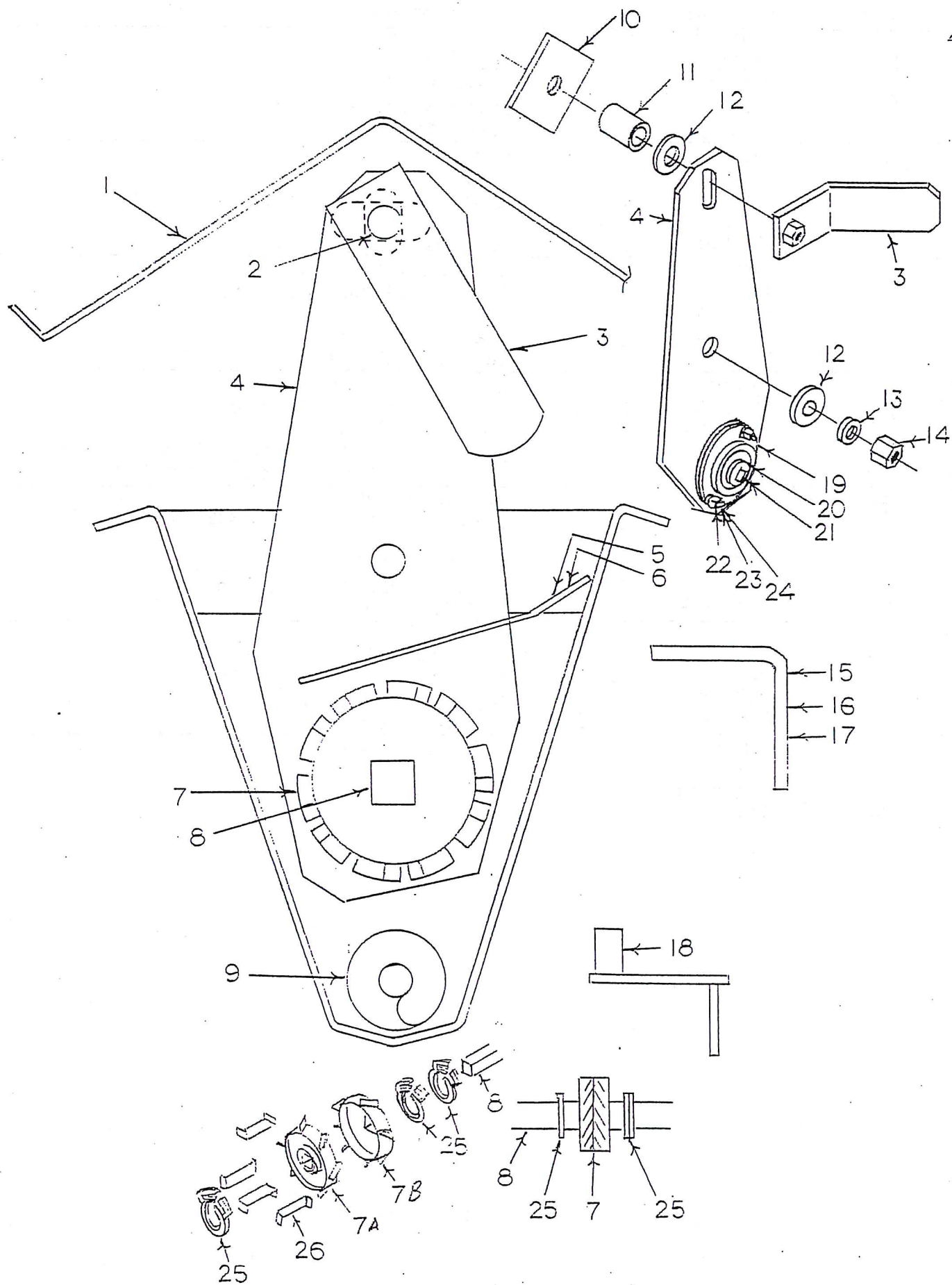

1068 DRILL PARTS BOOKS

REF.	PART NO.	QTY.	DESCRIPTION
1	7400214	3	Perferated Screen
2	4900129	4	Carriage Bolt $\frac{1}{2}$ x $2\frac{1}{2}$
3	7400215	4	Hinge Plate Lock Handle
4	7400216	4	Feed Shaft Hinge Plate
5	7400217	2	Feed Wheel Cover $39\frac{1}{2}$ " Long
6	7400218	1	Feed Wheel Cover $43\frac{1}{2}$ " Long
7	7500006	17	Feed Wheels
7A	7500007	17	Feed Wheel Left Half Marked L
7B	7500008	17	Feed Wheel Right Half Marked R
8	7600013	1	Feed Wheel Shaft $5/8$ " Sq. x 132 $3/8$ " Long
9	7400219	1	Clean Out Auger
10	7400220	4	Seal Plate
11	7400221	4	Brg. Hanger Plate
12	5000004	8	$\frac{1}{2}$ " Flat Washer
13	5000006	4	$\frac{1}{2}$ " Lock Washer
14	4900001	4	$\frac{1}{2}$ " Nut
15	7400222	1	Wheel Space Gage $3/8$ "
16	7400223	1	Wheel Space Gage $\frac{1}{4}$ "
17	7400224	1	Wheel Space Gage 10 Ga.
18	7400225	1	Clean Out Auger Handle
19	2100003	8	Flangette 1" 52-MST-C2
20	2000002	4	1" Bearing
21	7400213	4	Sq. Hole Sleeve
22	4900130	8	Bolt $5/16$ x $3/4$
23	5000002	8	$5/16$ " Lock Washer
24	4900003	8	$5/16$ " Hex Nut
25	7500034	51	Nylon Snap Lock Ring 1 On Left 2 On Right
26	7400066	68	Feed Wheel Retainer Clips

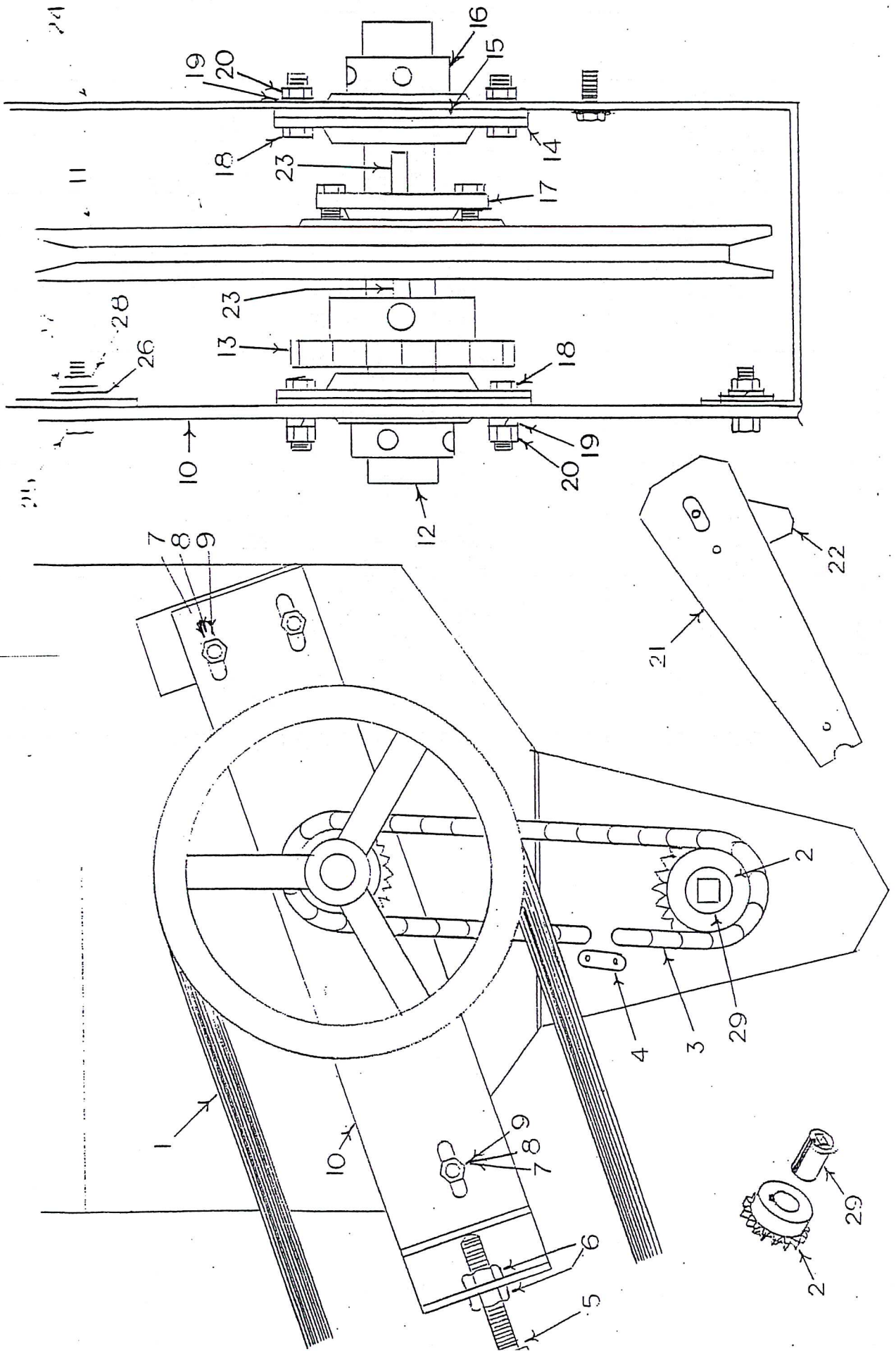

1068 DRILL PARTS BOOKS

REF.	PART NO.	QTY.	DESCRIPTION
1	1600027	1	Belt B-108
2	1000070	1	50-15-114 Sprocket
3	1100074	1	49 Links No. 50# Chain
4	1100059	1	#50 Connector Link
5	4800135	1	$\frac{1}{2}$ x $3\frac{1}{2}$ Bolt
6	4900001	2	$\frac{1}{2}$ Nuts
7	4800003	3	$\frac{3}{8}$ x 1 Bolt
8	5000001	3	$\frac{3}{8}$ Flat Washer
9	4900030	3	$\frac{3}{8}$ Plastic Lock Nut
10	7400235	1	Belt Tightener Plate
11	1400030	1	Pulley No. BK110H 10 $\frac{3}{4}$ OD
12	7600014	1	Idler Shaft 1" x 6 $\frac{3}{4}$ "
13	1000056	1	15 Tooth Sprocket #50 x 1"
14	2100003	4	Flangetts 1" 52-MST-C2
15	2000002	2	1" Bearing W/Collars
16	With #15		
17	1500003	1	Hub 1"
18	4800130	4	$\frac{5}{16}$ x $\frac{3}{4}$ Bolt
19	5000002	4	$\frac{5}{16}$ Lock Washer
20	4900003	4	$\frac{5}{16}$ Nut
21	7400236	1	Belt Shield
22	7400237	1	Chain Gaurd
23	6200010	2	$\frac{1}{2}$ x 1" Keys
24	7400238	1	Bearing Plate
25	4800003	4	$\frac{3}{8}$ x 1" Bolt
26	5000001	4	$\frac{3}{8}$ Flat Washer
27	5000019	4	$\frac{3}{8}$ Lock Washer
28	4900002	4	$\frac{3}{8}$ Nut
29	7400250	1	Sq. Hole Sleeve 2 $\frac{1}{8}$ " Long W/k.w.

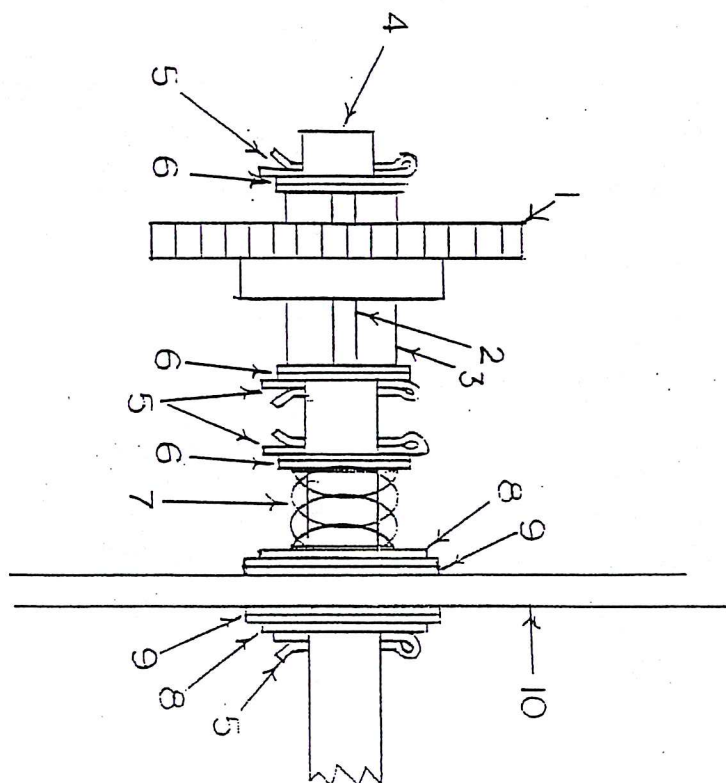



1968 DRILL PARTS BOOKS

REF.	PART NO.	QTY.	DESCRIPTION
1	1000070	1	50-15-114 Sprocket $\frac{1}{4}$ Key
2	6200010	1	$\frac{1}{4}$ x 1 Key
3	7400250	1	Sq. Hole Sleeve W/K.W.
4	7600013	1	Sq. Shaft $\frac{5}{8}$ x 132 $\frac{3}{8}$ "
5	4800050	4	Cotter Key $\frac{3}{16}$ " x $1\frac{1}{2}$ "
6	5000027	(as needed)	$1\frac{1}{2}$ OD $\frac{7}{8}$ ID Shim Washer
7	6100016	1	Coilspring
8	5000013	2	Steel Washer $\frac{5}{8}$ Sq. Hole
9	5000028	4	Nylon Washer $2\frac{1}{2}$ OD
10	(Not Replaceable)		Tank End Plate

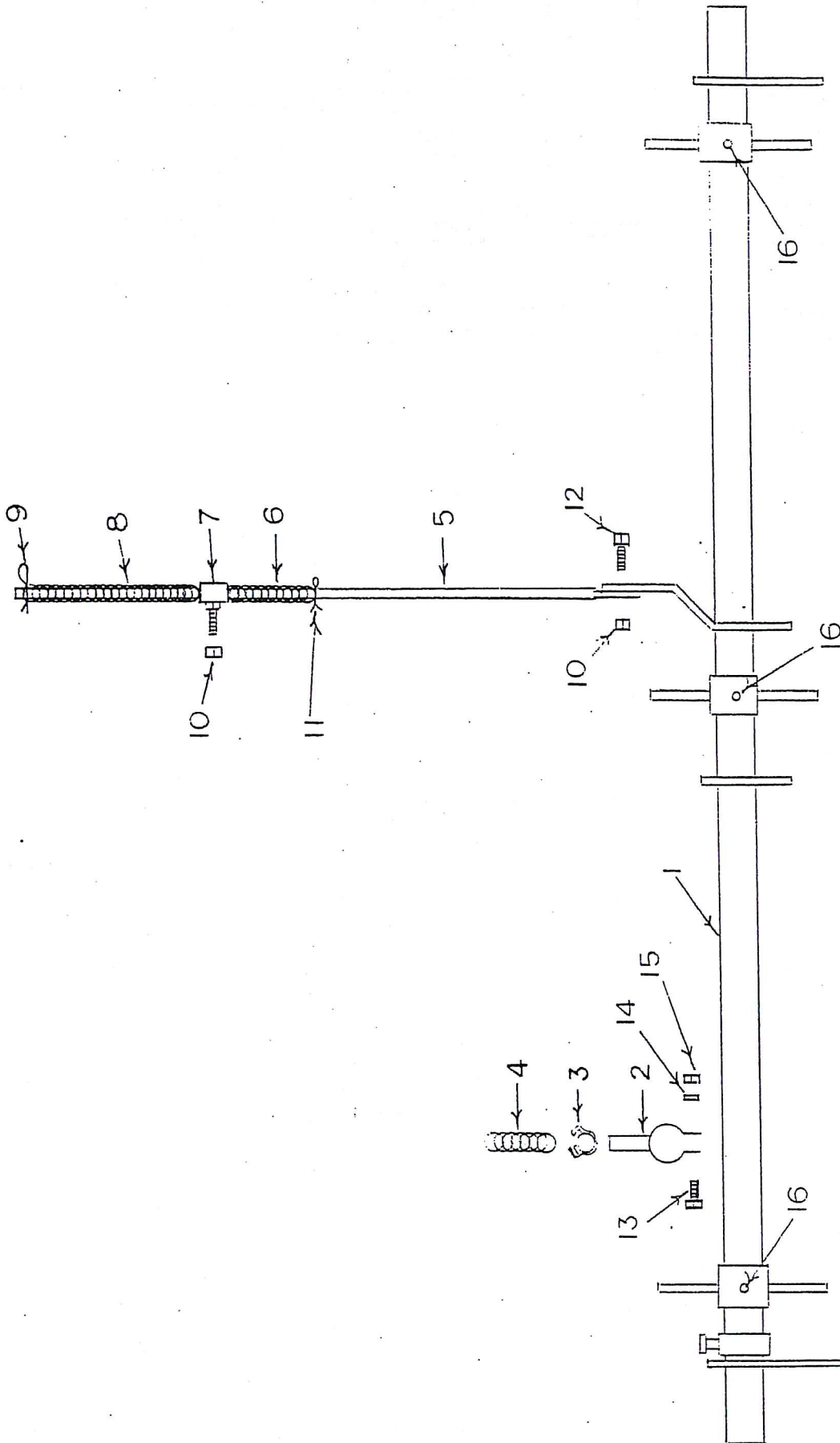

1068 DRILL PARTS BOOK

REF.	PART NO.	QTY.	DESCRIPTION
1	7400185	1	Torque Tube
2	7400186	17	Spring Anchor
3	7500034	17	SpringClamp Nylon Snap - SNP-16
4	6100019	17	Spring - 1" x 53/8"
5	7400187	1	Push Pull Rod
6	6100025	1	Spring- 1" x 3"
7	7400188	1	Push Pull Rod Slide
8	6100017	1	Spring - 1" x k2"
9	4800042	1	1/4 Hair Pin
10	4900014	2	1/2 Lock Nut Plated Crimped End
11	4800117	1	1/4 x 1 1/2" Cotter
12	4800018	1	1/2 x k 1/2 Bolt Plated
13	4800118	17	5/16 x 2" Bolt Plated
14	5000022	17	5/16 Lock Washer
15	4900003	17	5/16 Nut Plated
16	3800043	3	1/8" Zerks Short

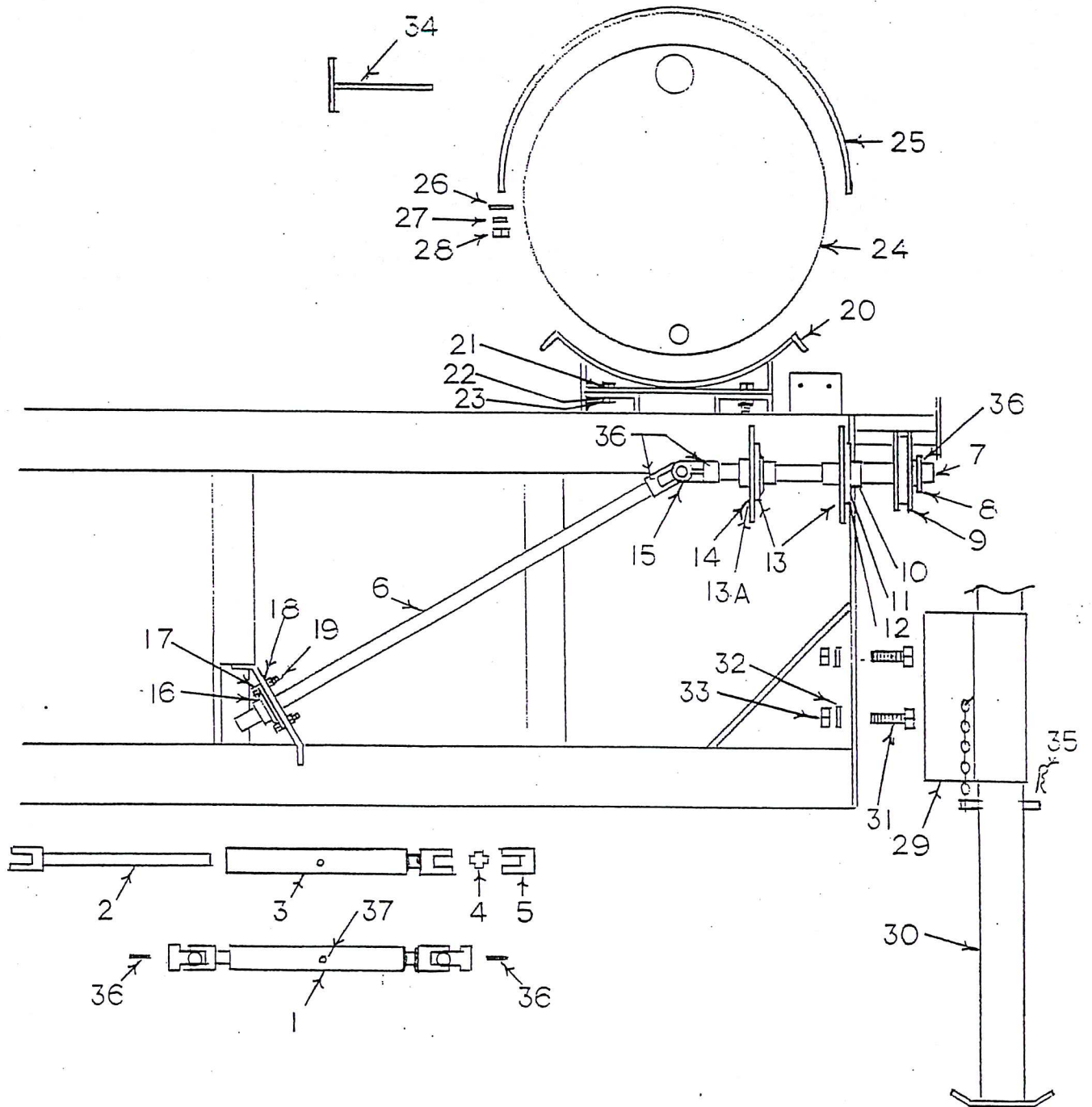

- 1068 DRILL PARTS BOOK

REF.	PART NO.	QTY.	DESCRIPTION
1	7400244	1	Colter Drive Shaft Assembly
2	7400245	1	Colter Drive Shaft Shaft w/Yoke
3	7400246	1	Colter Drive Shaft Tube w/Yoke
4	3600090	2	Cross and Brg. Kit #10
5	3600089	2	1" Rd. Yokes #10
6	7600015	1	Colter Drive Shaft 1" X 27"
7	7600016	1	Colter Drive Shaft 1" X 12"
8	1500003	1	1" Hub HX-1
9	1400021	1	Pully BK-57-H 5½" O.D.
10	w/#12	2	1" Locking Collar
11	2100003	4	1" Flangette
12	2000002	2	1" Bearing
13	4800130	4	5/16" x 3/4 Bolt
13A	5000002	4	5/16" Lock Washer
14	4900003	4	5/16 Hex Nut
15	3600091	1	U Joint 1" RD to 1" RD #10
16	1900010	1	1" 2 Hole Cast Bearing w/Lock Collar
17	4800098	2	3/8 x 1½ Bolt
18	5000019	2	3/8 Lock Washer
19	4900002	2	3/8 Hex Nut
20	7400239	8	Saddle
21	4800085	16	½ x 1" Bolt
22	5000004	16	½ Flat Washer
23	4900014	16	½ Lock Nut
24	7500043	4	Ballast Tank
25	7400240	8	Strap
26	5000001	16	3/8 Flat Washer
27	5000019	16	3/8 Lock Washer
28	4900002	16	3/8 Hex Nut
29	7400241	2	Jack Stand Anchor
30	7400242	2	Jack Stand
31	4800082	4	½ x 1½" Bolt
32	5000006	4	½ Lock Washer
33	4900001	4	½ Hex Nut
34	7400243	1	Ballast Tank Wrench
35	4800042	2	¼ Hair Pin
36	6200010	5	½" x 1" Keys
37	3800043	1	1/8" Straight Zerk

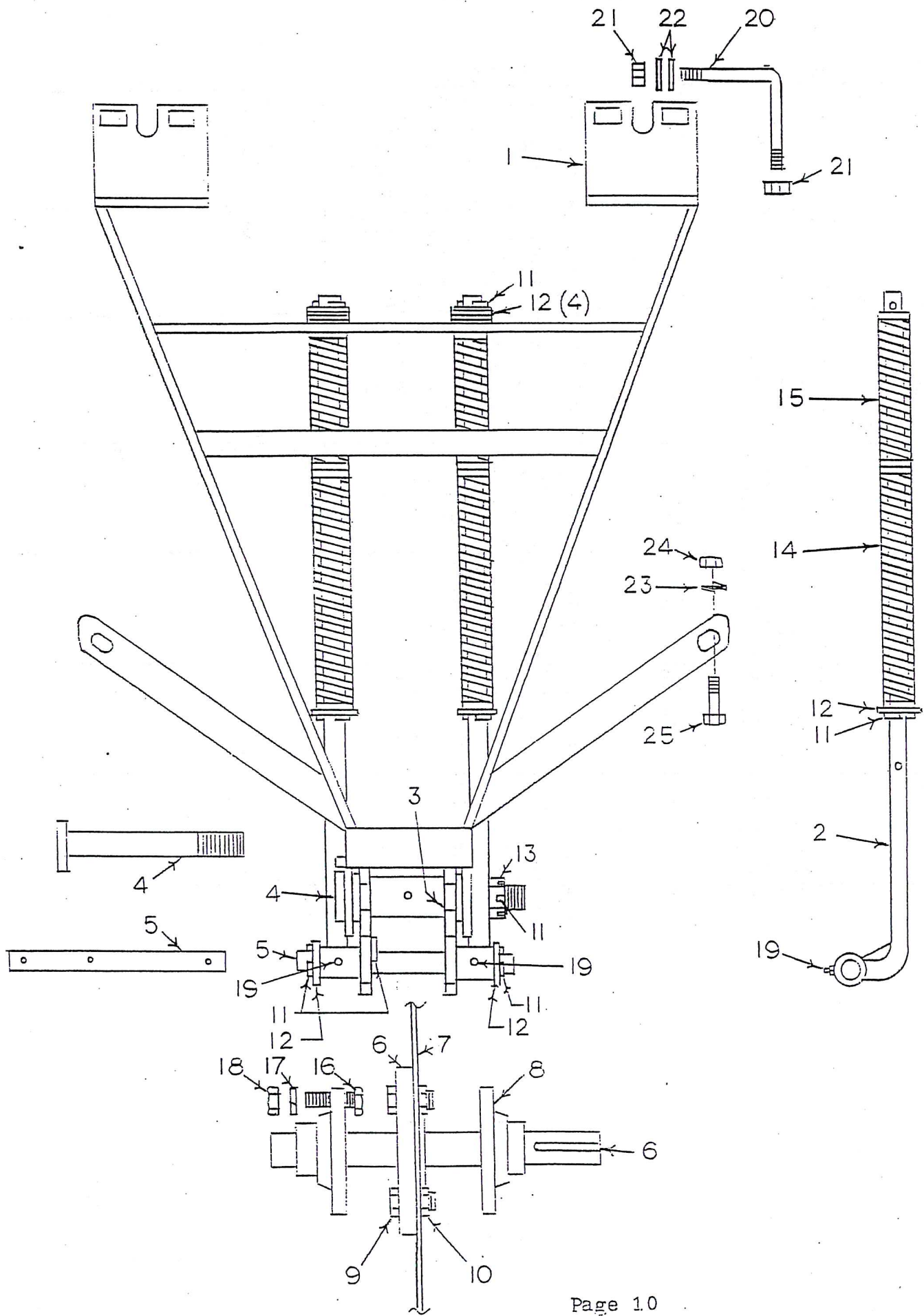

1068 DRILL PARTS BOOK

REF.	PART NO.	QTY.	DESCRIPTION
1	7400179	1	Drive Colter Frame
2	7400180	2	Pressure Rod
3	7400181	1	Drive Colter Fork
4	7400182	1	Fork Pin
5	7400183	1	Spring Anchor Shaft
6	7400184	1	Colter Axle, 1"
7	7500023	1	20" Colter Blade
8	1900010	2	1" (2 hole) Cast Flange Bearing, W/lock collar
9	4800018	4	$\frac{1}{2}$ " X $1\frac{1}{4}$ " Bolt
10	4900014	4	$\frac{1}{2}$ " Locking Nut
11	4800050	8	Cotter Pin, $\frac{3}{16}$ " X $1\frac{1}{2}$ "
12	5000005	12	$\frac{3}{4}$ " Flat Washer $1\frac{1}{2}$ " O.D.
13	4900020	1	1" Slotted Nut
14	6100017	2	12 X $1\frac{1}{8}$ " O.D. Spring
15	6100024	2	8 X $1\frac{1}{8}$ " O.D. Spring
16	4800034	4	$\frac{3}{8}$ " X $1\frac{1}{2}$ " Bolt
17	5000019	4	$\frac{3}{8}$ " Lock Nut
18	4900002	4	$\frac{3}{8}$ " Hex Nut
19	3800043	3	$\frac{1}{8}$ " Zerk (short zerks)
20	4800116	2	L Bolt, $\frac{3}{4}$ " Dia. $4\frac{1}{2}$ " X $4\frac{1}{2}$ "
21	4900013	4	$\frac{3}{4}$ " Crimped End Lock Nut, Plated
22	5000005	4	$\frac{3}{4}$ " Flat Washer
23	5000003	2	$\frac{5}{8}$ " Lock Washers
24	4900005	2	$\frac{5}{8}$ " Nuts
25	4800010	2	$\frac{5}{8}$ " X 2" Bolts

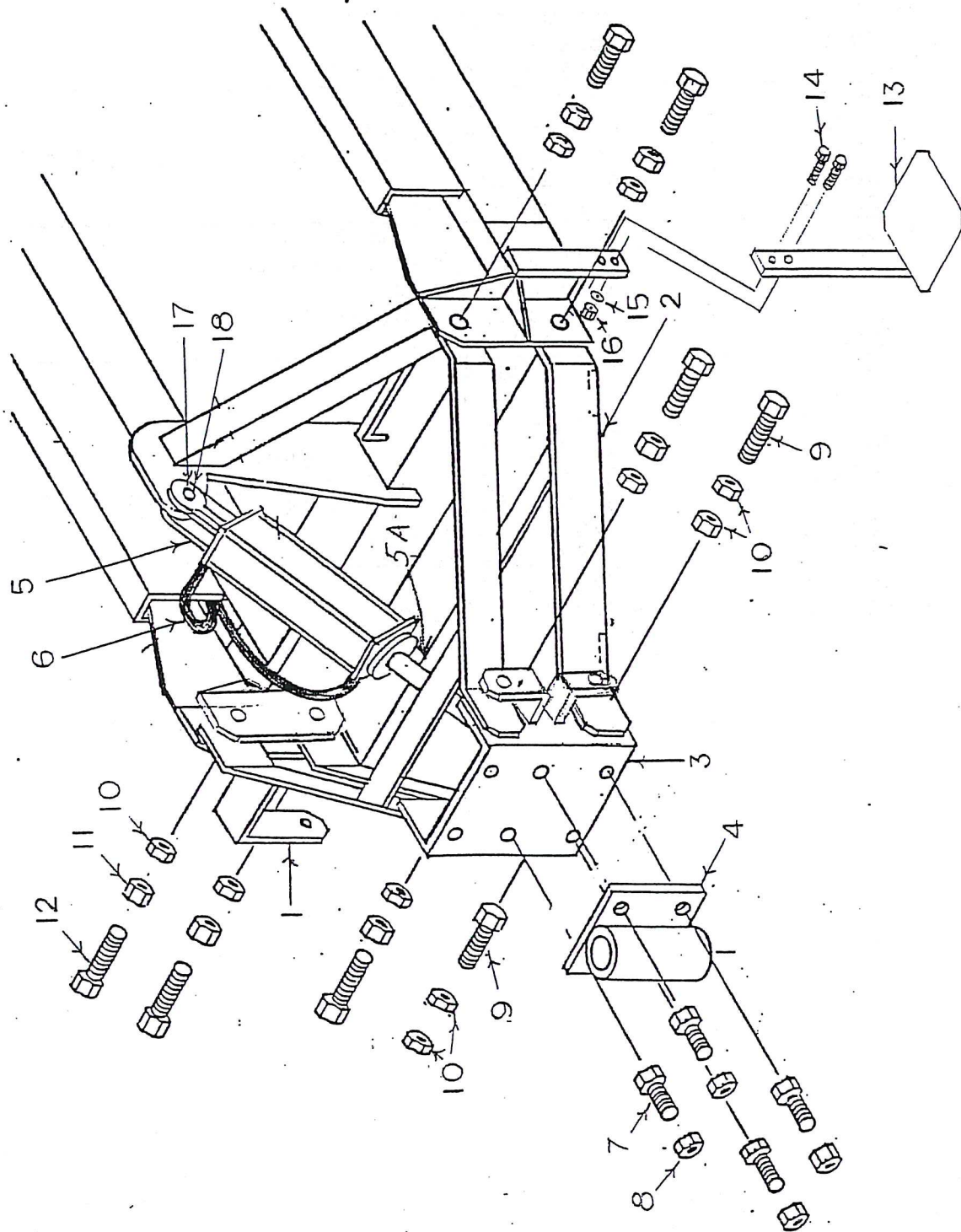



1068 DRILL PARTS BOOKS

REF.	PART NO.	QTY.	DESCRIPTION
1	7400231	1	Parallel Bar Upper
2	7400232	1	Parallel Bar Lower
3	7400233	1	Swivel Wheel Channel
4	7400234	1	Swivel Wheel Pivot Block
5	4100003	1	2½ x 8" Cyl. With 2½ Long Spacer
5A	7400230	1	2½" Long Spacer Sleeve-(Not Shown)
6	3700069	2	3/8 Rubber Hoses 11½ Ft. Long
7	4800010	4	5/8" x 2" Bolt
8	4900012	4	5/8" Lock Nut
9	4800115	2	3/4 x 2½ Bolt Grade 5
10	4800052	10	3/4" Jam Nut
11	4900004	6	3/4" Hex Nut
12	4800134	6	3/4 x 3" Bolt Grade 5
13	7400229	1	Step
14	4800082	2	½ x 1½ Bolt
15	5000005	2	½ lock Washer
16	4900001	2	½ Hex Nut
17	4100020	2	Cyl. Pins
18	4100021	4	Cotter Keys

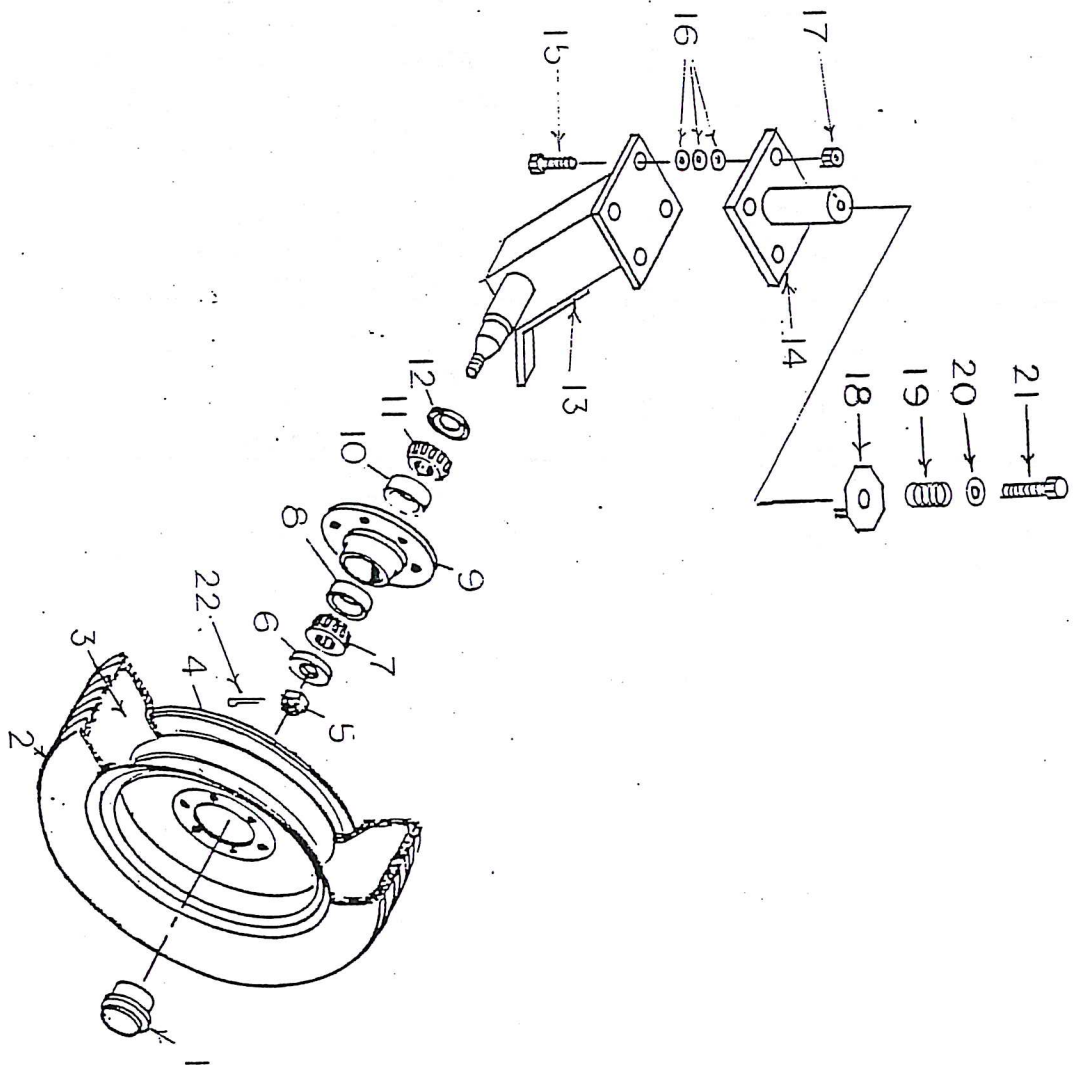

1068 DRILL PARTS BOOK

REF.	PART NO.	QTY.	DESCRIPTION
1	2900071	2	Dust Cap
2	2600012	2	Tire 14"
3	2700008	2	Tube 14"
4	2800016	2	Wheel 14"
5	3000014	2	Nut 5/8"
6	3000015	2	Washer 5/8"
7	2900072	2	Cone, outer
8	2900073	2	Cup, outer
9	2900074	2	Hub, 5 bolt
10	2900017	2	Cup, inner
11	2900018	2	Cone, inner
12	2900075	2	Grease Seal
13	7400247	1	Swivel Wheel Leg
14	7400248	1	Swivel Wheel Pivot Pin and Plate
15	4800021	4	5/8 X 3" Bolt
16	5000002	12	5/8 Flat Washer
17	4900012	4	5/8 Lock Nut
18	7400249	1	Retarder Plate & Pin
19	6100005	1	Spring, 2 3/8 X 1 1/4 O.D.
20	5000005	1	3/4 X 1 1/2 O.D. Washer
21	4800054	1	5/8 X 3 1/2 Bolt
22	4800050	2	Cotter Key, 3/16" X 1 1/2
23	2900070	1	Hub complete

*Hub studs bolts same as H1100*

*Pressure Roller*

106<sup>8</sup> Drill Parts Books

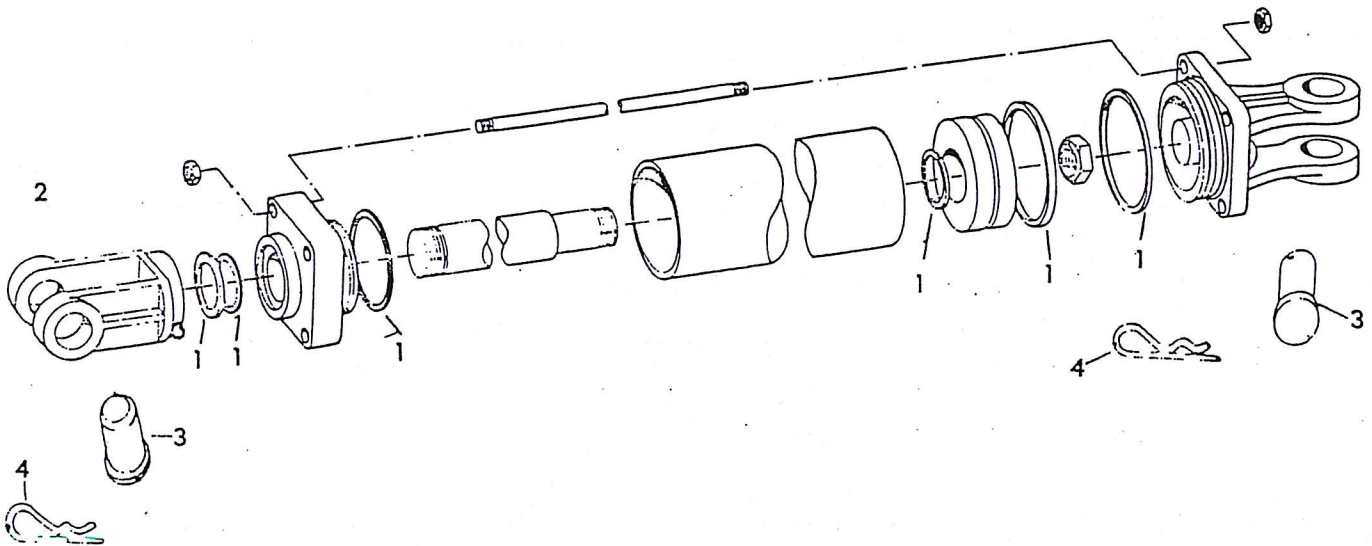

REF:	PART NO.	QTY.	DESCRIPTION
1	4100018	1	Seal Kit
2	4100019	1	Yoke
3	4100020	2	Pin
4	4100021	2	Key
5	4100003	1	Cyl. Complete 2.5 x 8

OPTION  
LIQUID APPLICATION TUBE

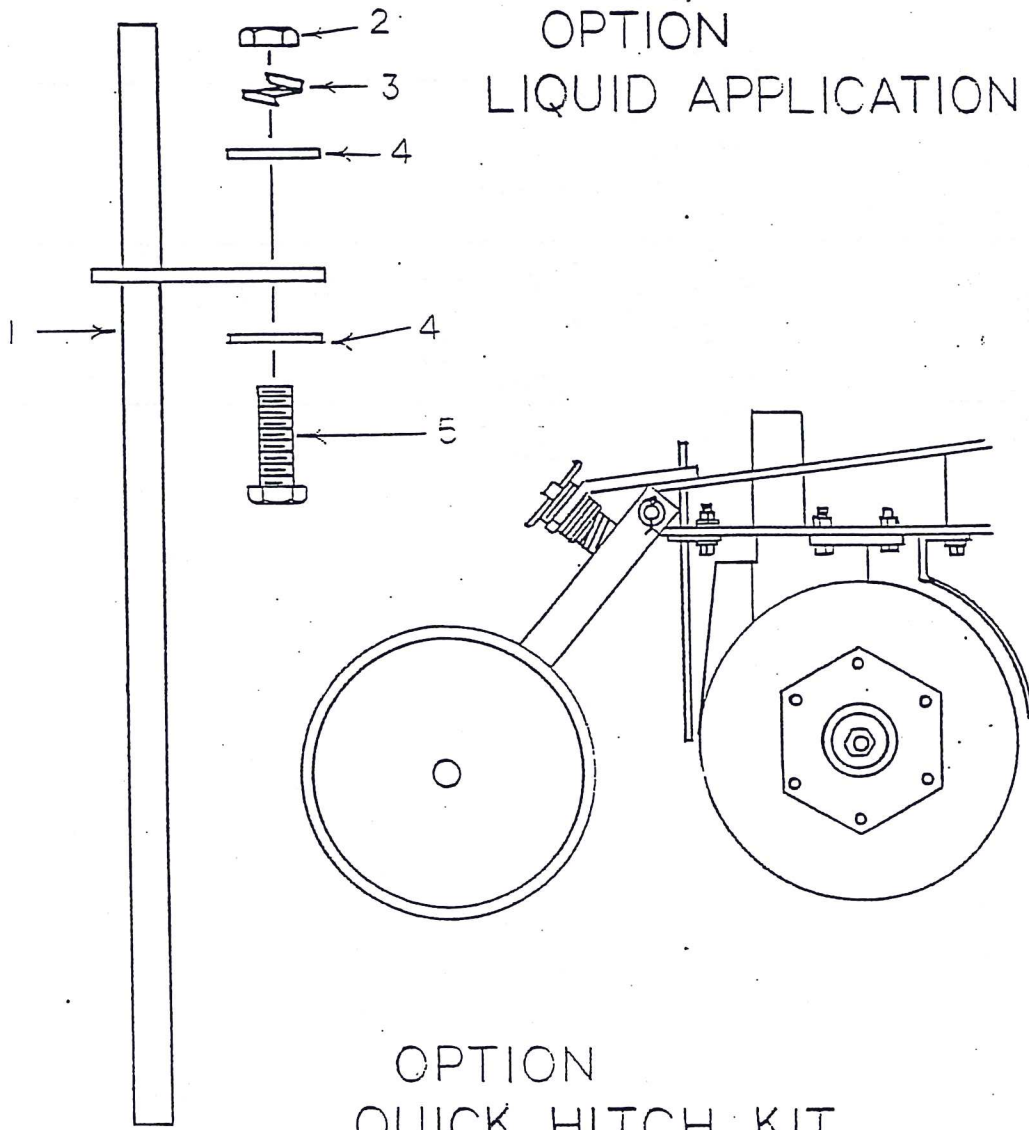

OPTION  
QUICK HITCH KIT

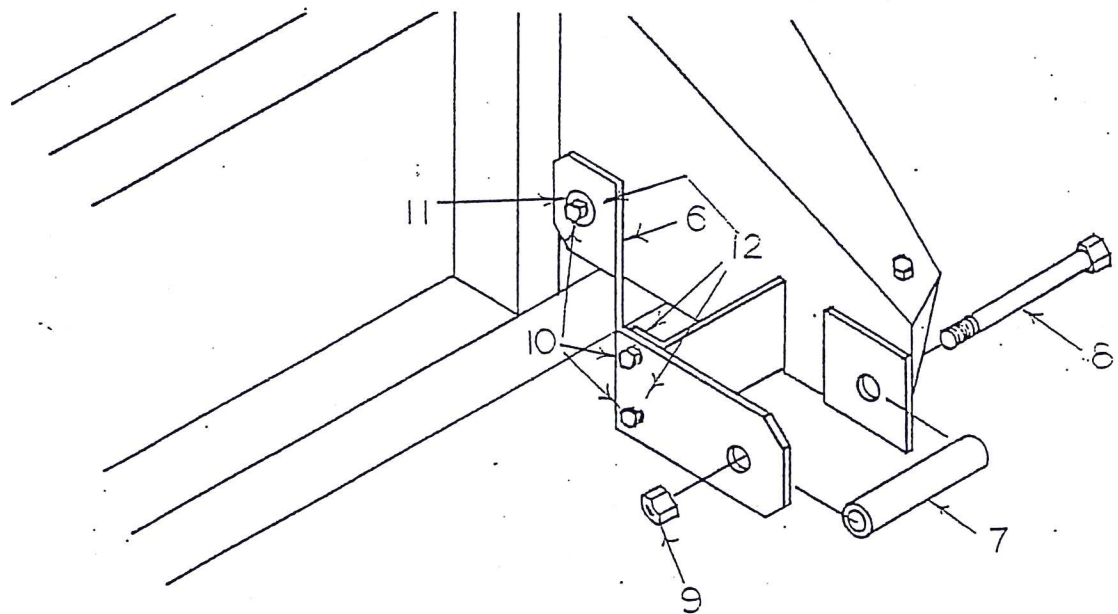

1068 DRILL PARTS BOOK

OPTION PARTS

REF.	PART NO.	QTY.	DESCRIPTION
1	7400251	1	Liquid Application Tube
2	4900002	1	5/16 Hex Nut
3	5000019	1	5/16 Lock Nut
4	5000001	2	5/16 Flat Washer
5	4800003	1	5/16 X 1" Bolt
6	7400252	2	Side Plates
7	7400253	2	Sleeves 1 7/16 O.D. 5 3/4 Long
8	4800136	2	1 1/8 X 8 1/2 N.F. Bolts
9	4900024	2	1 1/8 Hex Nut N.F.
10	4800010	6	5/8 X 2" Bolts
11	5000002	4	5/8 Flat Washer
12	4900012	6	5/8 Lock Nuts

# OPTION PART HITCH EXTENSION

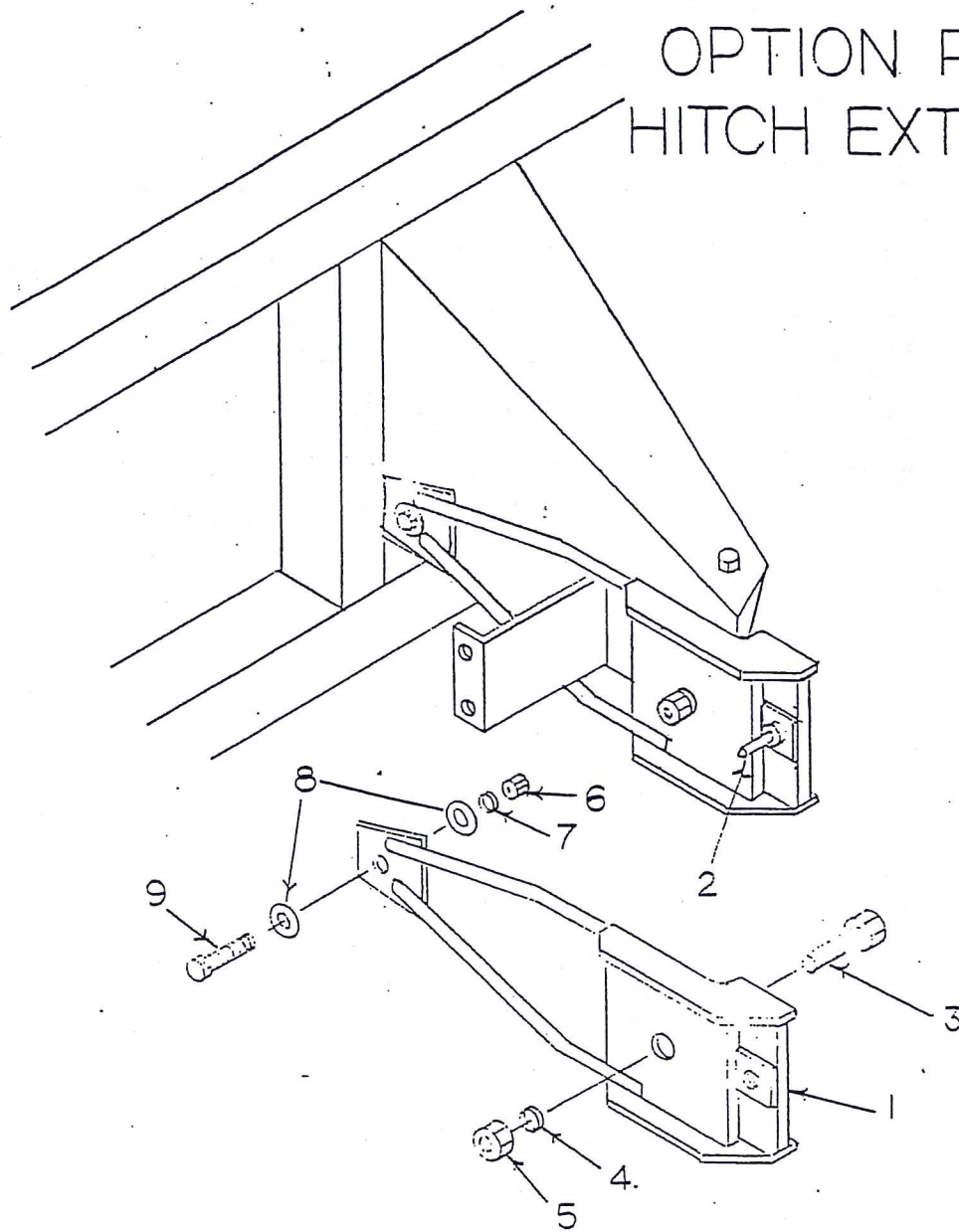

On some tractor models, it may be difficult to obtain enough clearance between the drive coupler and the rear of the tractor. The optional hitch extension will move the drill back five inches from the tractor to provide more operating clearance for the coupler.

When using these extensions it may be necessary to add more weight to the front of the tractor to keep the front wheels firmly on the ground.

1068 DRILL PARTS BOOK

5" HITCH EXTENSION PARTS LIST

<u>REF.</u>	<u>PART NO.</u>	<u>QTY.</u>	<u>DESCRIPTION</u>
1	7400254	2	5" Extension
2	4900086	2	Link Pin (Remove From Drill and Replace in Extension)
3	4800138	2	1 1/8" x 3" Bolt <u>NF Thread</u>
4	5000025	2	1 1/8" Lock Washer
5	4900005	2	1 1/8" <u>NF Thread Nut</u>
6	4900005	2	5/8" Standard Hex Nut
7	5000003	2	5/8" Lock Washer
8	5000002	4	5/8" Flat Washer
9	4800010	2	5/8" x 2" Bolt (NC Thread)



## GRAIN FEED CUP R.P.M.

Speeds are at 5 M.P.R. ground speed. Feed rate will increase or decrease as ground speed changes. The 3 sprockets at left end of drill (12-20-30), the 14 changes on the reduction unit and the double run feed cup allow 84 different feed rates.

30 TOOTH SPROCKET			20 TOOTH SPROCKET			12 TOOTH SPROCKET		
Setting		R.P.M.	Setting		R.P.M.	Setting		R.P.M.
A-7	slow	12.7	A-7	slow	8.5	A-7	slow	5.1
A-6		13.3	A-6		8.9	A-6		5.3
A-5		14.0	A-5		9.3	A-5		5.6
B-7	I	14.4	B-7	I	9.6	B-7	I	5.7
A-4	N	14.8	A-4	N	9.8	A-4	N	5.9
B-6	C	15.1	B-6	C	10.1	B-6	C	6.0
A-3	R	15.6	A-3	R	10.4	A-3	R	6.2
B-5	E	15.9	B-5	E	10.6	B-5	E	6.3
A-2	F	16.5	A-2	F	11.0	A-2	F	6.6
B-4	L	16.7	B-4	L	11.1	B-4	L	6.7
A-1	O	17.5	A-1	O	11.7	A-1	O	7.0
B-3	W	17.7	B-3	W	11.8	B-3	W	7.1
B-2	↓	18.7	B-2	↓	12.5	B-2	↓	7.5
B-1	fast	19.9	B-1	fast	13.2	B-1	fast	7.9

# GRAIN CUP FEED RATES

30-20-12 are sprockets at left end of drill.

Left is small side of cup - Right is large side.

WHEAT	OATS	BARLEY	FLAX
62 lbs. BU. Left side	32 lbs. BU. Right Side	48 lbs BU. Right side	56 lbs BU. Left Side
<div style="border: 1px solid black; padding: 5px; margin-bottom: 10px;">                     30 Tooth                      B-3      100 lbs                      B-4      94 lbs                      B-5      90 lbs                      B-6      85 lbs                      B-7      81 lbs                      A-6      75 lbs                 </div>	<div style="border: 1px solid black; padding: 5px; margin-bottom: 10px;">                     30 Tooth                      A-2      88 lbs                      B-6      80 lbs                      A-5      75 lbs                      A-7      68 lbs                 </div>	<div style="border: 1px solid black; padding: 5px; margin-bottom: 10px;">                     20 Tooth                      A-5      84 lbs                      A-6      80 lbs                      A-7      77 lbs                 </div>	<div style="border: 1px solid black; padding: 5px; margin-bottom: 10px;">                     20 Tooth                      A-2      58 lbs                      A-4      51 lbs                      A-7      44 lbs                 </div>
<div style="border: 1px solid black; padding: 5px; margin-bottom: 10px;">                     20 Tooth                      B-2      73 lbs                      A-1      68 lbs                      A-2      64 lbs                      A-3      60 lbs                      B-7      56 lbs                      A-6      51 lbs                      A-7      49 lbs                 </div>	<div style="border: 1px solid black; padding: 5px; margin-bottom: 10px;">                     20 Tooth                      B-1      70 lbs                      B-3      63 lbs                      A-2      58 lbs                      B-6      54 lbs                      A-5      49 lbs                      A-7      45 lbs                 </div>	<div style="border: 1px solid black; padding: 5px; margin-bottom: 10px;">                     12 Tooth                      B-1      72 lbs                      B-2      68 lbs                      A-1      64 lbs                      A-2      60 lbs                 </div>	<div style="border: 1px solid black; padding: 5px; margin-bottom: 10px;">                     12 Tooth                      B-2      39 lbs                      A-2      35 lbs                      B-6      31 lbs                      A-5      29 lbs                      A-7      26 lbs                 </div>
<div style="border: 1px solid black; padding: 5px;">                     12 Tooth                      B-1      42 lbs                      B-3      38 lbs                      B-4      35 lbs                      B-6      32 lbs                      A-5      30 lbs                 </div>	<div style="border: 1px solid black; padding: 5px;">                     20 Tooth                      Left side                      B-2      30 lbs                      B-6      24 lbs                      A-7      20 lbs                 </div>		

