

Operating Instructions and Parts Reference

CMF-710TM

VERTICAL MIXER



PRODUCT INFORMATION



0500151 • NOVEMBER 2019

ORIGINAL INSTRUCTIONS

DURATECH INDUSTRIES INTERNATIONAL INC.
PO Box 1940, JAMESTOWN, ND 58402-1940
TEL: (701) 252-4601 • FAX: (701) 252-0502
WWW.DURATECHINDUSTRIES.NET • WWW.HAYBUSTER.COM

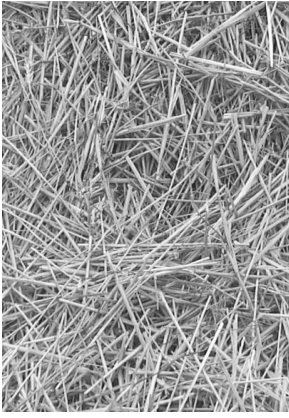

HAYBUSTER[®]
A Tradition of Innovation Since 1966

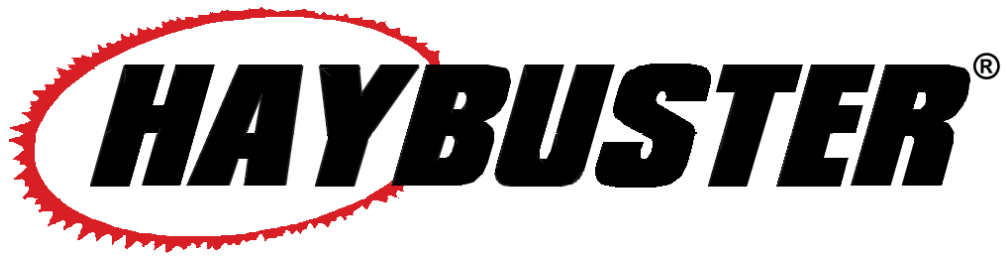
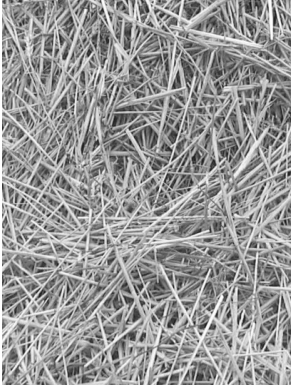



CMF-710TM VERTICAL MIXER

Operating Instructions and Parts Reference

DuraTech Industries International Inc. (DuraTech Industries) has made every effort to assure that this manual completely and accurately describes the operation and maintenance of the *CMF-710TM* as of the date of publication. DuraTech Industries reserves the right to make updates to the machine from time to time. Even in the event of such updates, you should still find this manual to be appropriate for the safe operation and maintenance of your unit.

This manual, as well as materials provided by component suppliers to DuraTech Industries are all considered to be part of the information package. Every operator is required to read and understand these manuals, and they should be located within easy access for periodic review.

 **DURATECH**[®] &  are registered trademarks of Duratech Industries International, Inc. *CMF-710* is a trademark of Duratech Industries International, Inc.

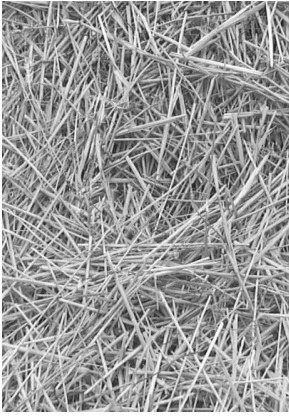

HAYBUSTER[®]
A Tradition of Innovation Since 1966

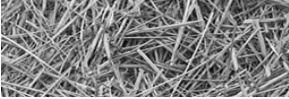

Foreword

All personnel must read and understand the following sections before operating the *CMF-710 VERTICAL MIXER*.

Appropriate use of unit\Introduction

Your model CMF-710 is designed to cut, mix and distribute feed rations including baled forage. It is designed for all bale sizes and ration moisture contents.



To avoid possible damage to the machine and risk of injury to the operator, consult with a DuraTech Industries International, Inc. (DuraTech Industries) representative before attempting to mix and distribute materials other than livestock forage.

The CMF-710 is used to mix hay and forage with grain and other supplements to feed livestock. The front conveyor with optional left, right or tandem discharge makes distribution of forage mix easier.

Statement of Misuse

This vertical mixer is not to be used for any purpose other than for which it is intended as explained in the operator's manual, advertising material and other pertinent written material prepared by DuraTech Industries. Any machine subject to misuse may cause personal injury or death, and void manufactures warranty.

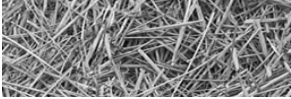

FOREWORD

Purpose

The purpose of this owner's manual is to explain maintenance requirements and routine adjustments for the most efficient operation of your CMF-710. There is also a trouble shooting section that may help in case of problems in the field. Any information not covered in this manual may be obtained from your dealer.



Special Note: When reference is made as to front, rear, right hand or left hand of this machine, the reference is always made from standing at the rear end of the machine and looking towards the hitch. Always use serial number and model number when referring to parts or problems. Please obtain your serial number and write it below for your future reference.

MODEL: CMF-710 VERTICAL MIXER SERIAL NO _____

How to use this manual

Manual organization

This manual is organized into the following parts:

- **Part 1:** Operating Manual explains how to set up, use and maintain the CMF-710 VERTICAL MIXER.
 1. Section 1: Safety
 2. Section 2: Dealer Preparation
 3. Section 3: Operation
 4. Section 4: Lubrication
 5. Section 5: Troubleshooting
 6. Section 6: Options
 7. Section 7: Maintenance

- **Part 2:** Parts Reference contains diagrams of each assembly, with the part number of each part. A key on the facing page contains a description of the part and the quantity used.
 1. The **parts reference** section can be found towards the back of this manual behind **Appendix B**.

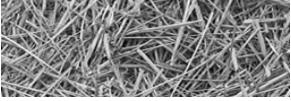

Dealer responsibilities

- Read Section 2, “Dealer Preparation,” and perform the tasks outlined. Also perform a pre-operation inspection as described in Section 3.
- Upon delivery of the unit to the customer, it is your responsibility to conduct a training session on the safe operation of the unit for primary operator(s). You must also conduct a “walk-around” inspection of all safety instructional decals on the machine itself. Decals are illustrated in **Part 2: Parts Reference**.
- Complete and return the Warranty Registration Card. Receipt of this form is required to activate the warranty. **Appendix A** provides details of the warranty.

Operator responsibilities

- Operator is responsible for his safety.
- Operator is also responsible for the safety of others near the machine.
- Review Section 2, “Dealer Preparation,” to verify that the machine has been prepared for use.
- Thoroughly review sections 1 and 3, which explain normal operation of the machine, and section 4, which explains maintenance requirements.
- Note the important safety information in the Forward and Section 1, “Safety”
- Keep copies of all manuals in a readily accessible location for future reference

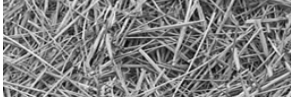

TABLE OF CONTENTS

Part I: Operating instructions	1
Section 1: Safety.....	2
1.1 Safety-alert symbols	2
1.2 Operator - personal equipment	4
1.3 Machine safety labels	5
1.4 Shielding.....	9
1.5 Safety review section	9
1.6 Towing/road transport	12
Section 2: Dealer Preparation	13
2.1 Pre-delivery inspection.....	13
Section 3: Operation	14
3.1 Pre-starting inspection instructions	15
3.2 Setup and Adjustments	16
3.2.1 Hitch Adjustments	16
3.2.2 Jack	16
3.2.3 P.T.O. Shield	17
3.2.4 Hydraulic Cylinder and Valve.....	17
3.2.5 Tires and Rims	18
3.2.6 Knives	18
3.2.7 Vertical knives.....	18
3.2.8 Free motion automatic clutch	19
3.2.9 Scale Indicator	19
3.2.10 Two-Speed Gearbox (Option).....	19
3.2.11 Extension Conveyor Spouts (Option)	19
3.2.12 Setting Chain Tensions on Conveyors	20
3.3 Hitching the CMF-710	21
3.4 Unhitching the CMF-710	22
3.5 Operation precautions and instructions	23
3.6 Starting the machine.....	23
3.7 Loading and processing.....	23
3.8 Unloading	24
3.9 Storing the CMF-710 mixer/feeder	24
3.10 Removing the CMF-710 from storage	25
3.11 Normal shut-down procedure	25
3.12 Light Kit	25

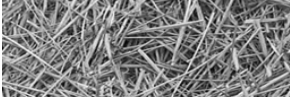

TABLE OF CONTENTS

Section 4: Lubrication	26
4.1 Lubrication	26
4.2 General appearance	31
Section 5: Troubleshooting	32
Section 6: Options	33
6.1 Rear bay door.....	33
6.2 Magnetic extension spouts.....	33
6.3 Non-magnetic extension spout	33
6.4 Two-Speed Gearbox	34
6.5 Dogleg Conveyor.....	35
Section 7: Maintenance	36
7.1 Welding Procedure	36
Appendix A: Warranty	37
Appendix B: CMF-710 Specifications	38

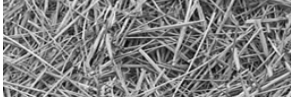

TABLE OF CONTENTS

Part II : Parts Reference.....39

TUB ASSEMBLY COMPLETE 40

TUB ASSEMBLY DETAIL A..... 41

TUB ASSEMBLY DETAILS B,C & D..... 42

TUB ASSEMBLY DETAIL E..... 43

TUB ASSEMBLY PARTS LIST 45

MAINFRAME ASSEMBLY 46

DRIVE LINE OPTION - STANDARD - 1-3/4 CV 48

DRIVE LINE OPTION - STANDARD - 1-3/8 CV 50

DRIVE LINE OPTION - 2 SPEED GEARBOX - 1-3/4 CV..... 52

DRIVE LINE OPTION - 2 SPEED GEARBOX - 1-3/8 CV..... 54

AUGER ASSEMBLY (FOR S.N. UP TO VM17002571) 56

AUGER ASSEMBLY (FOR S.N. VM17002671 AND UP) 58

LEFT HAND DISCHARGE CONVEYOR ASSEMBLY 60

COMPLETE LEFT HAND DISCHARGE CONVEYOR ASSEMBLY 62

RIGHT HAND DISCHARGE CONVEYOR ASSEMBLY..... 64

COMPLETE RIGHT HAND DISCHARGE CONVEYOR ASSEMBLY 66

DUAL DISCHARGE CONVEYOR ASSEMBLY (OPTION)..... 68

MAIN CONVEYOR ASSEMBLY-4704973 - SUB ASSEMBLY 1
(USE W/ DUAL & RH DISCHARGE) 70

MAIN CONVEYOR ASSEMBLY-4704973 - SUB ASSEMBLY 2
(USE W/ DUAL & RH DISCHARGE) 71

MAIN CONVEYOR ASSEMBLY-4704973 - DETAIL A (USE W/ DUAL & RH
DISCHARGE)..... 72

MAIN CONVEYOR ASSEMBLY-4704973 - PARTS LIST
(USE W/ DUAL & RH DISCHARGE) 73

MAIN CONVEYOR ASSEMBLY-4704972 - SUB ASSEMBLY 1
(USE W/LH DISCHARGE)..... 74

MAIN CONVEYOR ASSEMBLY-4704972 - SUB ASSEMBLY 2
(USE W/LH DISCHARGE)..... 75

MAIN CONVEYOR ASSEMBLY-4704972 - DETAIL A
(USE W/LH DISCHARGE)..... 76

MAIN CONVEYOR ASSEMBLY-4704972 - PARTS LIST
(USE W/LH DISCHARGE)..... 77

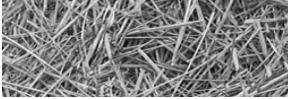

TABLE OF CONTENTS

OPTIONAL-LH DOGLEG DISCHARGE CONVEYOR (FOR S.N. UP TO VM18004071)	78
OPTIONAL-LH DOGLEG DISCHARGE CONVEYOR PARTS LIST (FOR S.N. UP TO VM18004071)	79
OPTIONAL-LH DOGLEG DISCHARGE CONVEYOR DETAILS A & B (FOR S.N. UP TO VM18004071)	80
OPTIONAL-LH DOGLEG DISCHARGE CONVEYOR COMPLETE (FOR S.N. UP TO VM18004071)	82
OPTIONAL-RH DOGLEG DISCHARGE CONVEYOR (FOR S.N. UP TO VM18004071)	84
OPTIONAL-RH DOGLEG DISCHARGE CONVEYOR PARTS LIST (FOR S.N. UP TO VM18004071)	85
OPTIONAL-RH DOGLEG DISCHARGE CONVEYOR DETAIL A (FOR S.N. UP TO VM18004071)	86
OPTIONAL-RH DOGLEG DISCHARGE CONVEYOR COMPLETE (FOR S.N. UP TO VM18004071)	88
OPTIONAL DOGLEG CONVEYOR #1 (FOR S.N. VM20004171 & UP)	90
OPTIONAL DOGLEG CONVEYOR #2 (FOR S.N. VM20004171 & UP)	92
OPTIONAL DOGLEG CONVEYOR #3 (FOR S.N. VM20004171 & UP)	94
MAGNETIC CONVEYOR CHUTE ASSEMBLY	96
NON-MAGNETIC CONVEYOR CHUTE ASSEMBLY	97
NON-MAGNETIC CONVEYOR END GATE ASSEMBLY	98
MAGNETIC CONVEYOR END GATE ASSEMBLY	99
HYDRAULIC TANK ASSEMBLY	100
SINGLE DISCHARGE CONVEYOR HYDRAULICS	102
SINGLE DISCHARGE CONVEYOR HYDRAULICS - DETAIL A	103
SINGLE DISCHARGE CONVEYOR HYDRAULICS - DETAIL B	104
SINGLE DISCHARGE CONVEYOR HYDRAULICS - DETAILS C AND D ..	105
SINGLE DISCHARGE CONVEYOR HYDRAULICS - DETAILS E AND F ..	106
SINGLE DISCHARGE CONVEYOR HYDRAULICS	107
GEARBOX HYDRAULIC SCHEMATIC	108
GEARBOX HYDRAULIC SCHEMATIC	109
OPTIONAL DOGLEG CONVEYOR HYDRAULIC SCHEMATIC	110

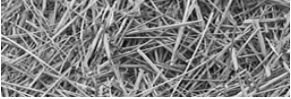
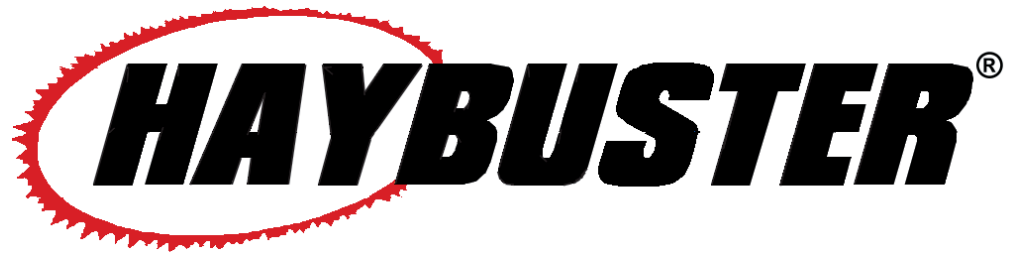
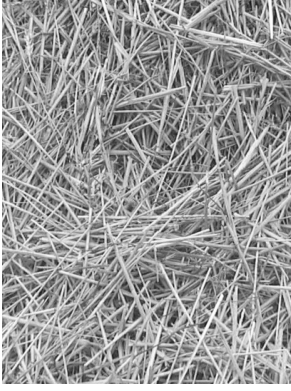

TABLE OF CONTENTS

OPTIONAL DOGLEG CONVEYOR HYDRAULIC SCHEMATIC DETAIL A	111
OPTIONAL DOGLEG CONVEYOR HYDRAULIC SCHEMATIC DETAIL B	112
OPTIONAL DOGLEG CONVEYOR HYDRAULIC SCHEMATIC DETAILS C AND D.....	113
OPTIONAL DOGLEG CONVEYOR HYDRAULIC SCHEMATIC DETAIL E	114
OPTIONAL DOGLEG CONVEYOR HYDRAULIC SCHEMATIC	115
ORBIT MOTORS 3900025-3900032	116
HYDRAULIC CYLINDER ASSEMBLY.....	118
3100225 - 2-SPEED GEARBOX ASSEMBLY	120
3100226 - PLANETARY GEARBOX ASSEMBLY	123
HUB ASSEMBLY	124
STANDARD DRIVELINE - 3600787	126
STANDARD DRIVELINE - 3600791	127
STANDARD DRIVELINE - 3600596.....	128
2-SPEED DRIVELINE - 3700783	129
2-SPEED DRIVELINE - 3600785.....	130
2 SPEED DRIVELINE - 3600819	131
DECALS	132
DECAL LOCATIONS	134
CMF TAIL LIGHTS WIRING SCHEMATIC	136
CMF-710 Documentation Comment Form.....	137



CMF-710TM VERTICAL MIXER

PART 1: Operating Instructions

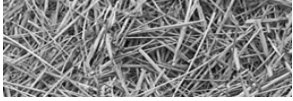

Section 1: Safety

The safety of the operator is of great importance to DuraTech Industries. We have provided decals, shield and other safety features to aid you in using your machine safely. In addition, we ask you to be a careful operator who will properly use and service your Haybuster equipment.



WARNING: FAILURE TO COMPLY WITH SAFETY INSTRUCTIONS THAT FOLLOW WITHIN THIS MANUAL COULD RESULT IN SEVERE PERSONAL INJURY OR DEATH. BEFORE ATTEMPTING TO OPERATE THIS MACHINE, CAREFULLY READ ALL INSTRUCTIONS CONTAINED WITHIN THIS MANUAL. ALSO READ THE INSTRUCTION MANUAL PROVIDED WITH YOUR TRACTOR.

THIS MACHINE IS NOT TO BE USED FOR ANY OTHER PURPOSE OTHER THAN THOSE EXPLAINED IN THE OPERATOR'S MANUAL, ADVERTISING LITERATURE OR OTHER DURATECH INDUSTRIES WRITTEN MATERIAL PERTAINING TO THE CMF-710.

1.1 Safety-alert symbols

Decals are illustrated in **Part 2: Parts Reference**.

The safety decals located on your machine contain important and useful information that will help you operate your equipment safely.

To assure that all decals remain in place and in good condition, follow the instructions below:

- Keep decals clean. Use soap and water - not mineral spirits, adhesive cleaners and other similar cleaners that will damage the decal.
- Replace all damaged or missing decals. When attaching decals, surface temperature of the machine must be at least 40° F (5° C). The surface must be also be clean and dry.
- When replacing a machine component to which a decal is attached, be sure to also replace the decal.

DuraTech Industries uses industry accepted **ISO/ANSI** standards in labeling its products for safety and operational characteristics.



Safety-Alert Symbol

Read and recognize safety information. Be alert to the potential for personal injury when you see this safety-alert symbol.

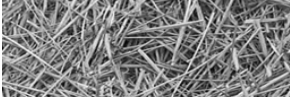

DANGER: Indicates an imminently hazardous situation that, if not avoided, will result in death or serious injury. This signal word is to be limited to the most extreme situations, typically for machine components that, for functional purposes, cannot be guarded.

WARNING: Indicates a potentially hazardous situation that, if not avoided, could result in death or serious injury, and includes hazards that are exposed when guards are removed. It may also be used to alert against unsafe practices.

CAUTION: Indicates a potentially hazardous situation that, if not avoided, may result in minor or moderate injury. It may also be used to alert against unsafe practices.

This manual uses the symbols to the right to denote important safety instructions and information.

The **DANGER**, **WARNING** and **CAUTION** symbols are used to denote conditions as stated in the text above. Furthermore, the text dealing with these situations is surrounded by a box with a white background, will begin with **DANGER**, **WARNING**, or **CAUTION**.

The **INFORMATION** symbol is used to denote important information or notes in regards to maintenance and use of the machine. The text for this information is surrounded by a box with a light grey background, and will begin with either **Important** or **Note**.



DANGER:
Signal word - White Lettering/Red Background
Safety Alert Symbol - White Triangle/Red Exclamation Point



WARNING:
Signal word - Black Lettering/Orange Background
Safety Alert Symbol - Black Triangle/Orange Exclamation Point



CAUTION:
Signal word - Black Lettering/Yellow Background
Safety Alert Symbol - Black Triangle/Yellow Exclamation Point



	<p>1. Yellow warning triangle/black graphical symbol, indicates what the hazard is. Hazard Identification</p>
	<p>2. Red circle-with-slash/black graphical symbol indicates a prohibited action to avoid the hazard. Prohibited Action</p>
	<p>3. Blue mandatory action circles/white graphical symbol - indicates an action to take to avoid the hazard. Mandatory Action</p>

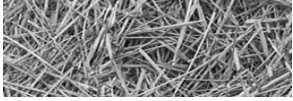

1.2 Operator - personal equipment

THE OPERATOR

Physical Condition

You must be in good physical condition and mental health and not under the influence of any substance (drugs, alcohol) which might impair vision, dexterity or judgment.

Do not operate a **CMF-710 VERTICAL MIXER** when you are fatigued. Be alert - If you get tired while operating your **CMF-710 VERTICAL MIXER**, take a break. Fatigue may result in loss of control. Working with any farm equipment can be strenuous. If you have any condition that might be aggravated by strenuous work, check with your doctor before operating

Proper Clothing



Clothing must be sturdy and snug-fitting, but allow complete freedom of movement. Avoid loosefitting jackets, scarfs, neckties, jewelry, flared or cuffed pants, unconfined long hair or anything that could become entangled with the machine.



Protect your hands with gloves when handling flail and sections. Heavyduty, nonslip gloves improve your grip and protect your hands.



Good footing is most important. Wear sturdy boots with nonslip soles. Steel-toed safety boots are recommended.



To reduce the risk of injury to your eyes never operate a **CMF-710 VERTICAL MIXER** unless wearing goggles or properly fitted safety glasses with adequate top and side protection.



Tractor noise may damage your hearing. Always wear sound barriers (ear plugs or ear muffers) to protect your hearing. Continual and regular users should have their hearing checked regularly.

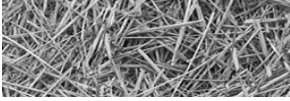

1.3 Machine safety labels

The safety decals located on your machine contain important information that will help you operate your equipment. Become familiar with the decals and their locations.

 **DANGER: ROTATING DRIVELINE, KEEP AWAY!**
ENTANGLEMENT CAN CAUSE SERIOUS INJURIES OR DEATH.

DO NOT OPERATE WITHOUT

- ALL DRIVELINE GUARDS, TRACTOR AND EQUIPMENT SHIELDS IN PLACE
- DRIVELINES SECURELY ATTACHED AT BOTH ENDS
- DRIVELINE GUARDS THAT TURN FREELY ON DRIVELINE

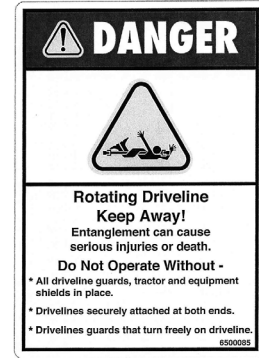

6500085

 **DANGER**

- ROTATING PARTS CAN ENTANGLE OR STRIKE PEOPLE, RESULTING IN DEATH.
- NEVER ENTER A MIXER/FEEDER WHILE IN OPERATION.
- OPERATE THE MIXER/FEEDER FROM THE OPERATOR'S SEAT ONLY.



6500383

 **WARNING: HIGH-PRESSURE FLUID HAZARD**

To prevent serious injury or death:

- Relieve pressure on system before repairing or adjusting or disconnecting.
- Wear proper hand and eye protection when searching for leaks. Use wood or cardboard instead of hands.
- Keep all components in good repair.



6500220

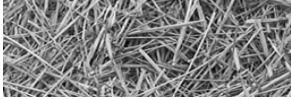

WARNING: PINCH POINT STAY BACK



6500339



WARNING: FOR YOUR PROTECTION AND SAFETY OF OTHERS, FOLLOW THESE SAFETY RULES.

1. Read and understand operators manual before operating machine.
2. Place all controls in neutral, stop engine, remove ignition key, lock out power source, and wait for all motion to stop before servicing, adjusting, repairing, or unplugging.
3. Read and understand all decals on machine for your safety.
4. Keep all shields in place while machine is in operation.
5. Keep hands, feet, hair, and clothing away from moving parts.
6. Keep others away from machine while in operation.
7. Install safety locks before transporting, or working beneath components.
8. Do not allow riders at any time.
9. Do not leave machine unattended with engine running.
10. Keep all hydraulic lines, couplings, and fittings free of leaks during operation.
11. Keep away from overhead electrical lines. Electrocutation can occur without direct contact.
12. Review safety instructions periodically.

	WARNING		ADVERTENCIA
FOR YOUR PROTECTION AND SAFETY OF OTHERS, FOLLOW THESE SAFETY RULES.		PARA SU PROTECCIÓN Y LA SEGURIDAD DE OTROS, OBSERVE ESTAS NORMAS DE SEGURIDAD	
<ol style="list-style-type: none"> 1. Read and understand operators manual before operating machine. 2. Place all controls in neutral, stop engine, remove ignition key, lock out power source, and wait for all motion to stop before servicing, adjusting, repairing, or unplugging. 3. Read and understand all decals on machine for your safety. 4. Keep all shields in place while machine is in operation. 5. Keep hands, feet, hair, and clothing away from moving parts. 6. Keep others away from machine while in operation. 7. Install safety locks before transporting, or working beneath components. 8. Do not allow riders at any time. 9. Do not leave machine unattended with engine running. 10. Keep all hydraulic lines, couplings, and fittings free of leaks during operation. 11. Keep away from overhead electrical lines. Electrocutation can occur without direct contact. 12. Review safety instructions periodically. 		<ol style="list-style-type: none"> 1. Lea y comprenda el manual del operador antes de operar la máquina. 2. Coloque todos los controles en punto neutro, apague el motor, retire la llave de encendido, cierre la alimentación de electricidad y espere a que se detenga toda el movimiento antes de proceder al servicio, ajuste, reparación o desenchufado. 3. Lea y comprenda todas las calcomanías adheridas a la máquina para su seguridad. 4. Mantenga todas las defensas en su lugar mientras la máquina está en funcionamiento. 5. Mantenga las manos, pies, cabello y ropa lejos de las partes en movimiento. 6. Mantenga a otras personas alejadas de la máquina en funcionamiento. 7. Instale trabas de seguridad antes de proceder al transporte o a trabajar debajo de los componentes. 8. No permita en ningún momento que otras personas viajen en la máquina. 9. No deje a la máquina sin operador con el motor encendido. 10. Mantenga todas las líneas hidráulicas, acoplamientos y accesorios sin fugas durante el funcionamiento. 11. Permanezca alejado de las líneas eléctricas elevadas. Puede producirse la electrocución sin contacto directo. 12. Analice las instrucciones de seguridad en forma periódica. 	

6500208





WARNING: NO RIDERS
SERIOUS INJURY COULD RESULT FROM RIDING ON THE MACHINE.

	WARNING		ADVERTENCIA
No Riders Serious personal injury could result from riding on the machine.			Pasajeros Prohibidos Podrían resultar lesiones personales graves al viajar en la máquina.

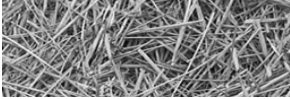
6500043





 **WARNING:** Risk of eye injury
Eye Protection required

 **WARNING**
Risk of eye injury.
Eye protection required.

6500487

6500487

 **WARNING:** Moving parts can crush and cut.
Keep hands clear.

 **WARNING**
Moving parts can crush and cut.
Keep hands clear.

6500488

6500488

 **WARNING:** Noise hazzard.
Ear protection required.

 **WARNING**
Noise hazard.
Ear protection required.

6500489

6500489

 **WARNING:** NO STEP
DO NOT STEP, STAND, OR SIT ON THIS SURFACE.
MAY CAUSE INJURY AND/OR EQUIPMENT DAMAGE.

 **WARNING**
No Step.
Do not step, stand or sit on this surface.
May cause injury and/or equipment damage.

6500490

6500490

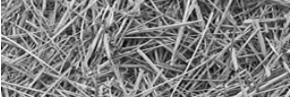

CAUTION: ADJUST TRACTOR DRAWBAR SO THAT THE DISTANCE FROM THE END OF THE PTO SHAFT ON THE TRACTOR TO THE CENTER OF THE DRAWBAR HITCH PIN IS EQUAL TO THE DISTANCE SHOWN IN DIAGRAM. SEE OWNER'S MANUAL FOR MORE INFORMATION.

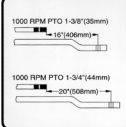
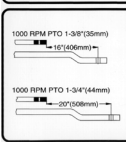
	<p>CAUTION</p> <p>ADJUST TRACTOR DRAWBAR SO THAT THE DISTANCE FROM THE END OF THE PTO SHAFT ON THE TRACTOR TO THE CENTER OF THE DRAWBAR HITCH PIN IS EQUAL TO THE DISTANCE SHOWN IN DIAGRAM. SEE OWNER'S MANUAL FOR MORE INFORMATION. 6500440</p>
	<p>PRECAUCION</p> <p>AJUSTAR LA BARRA DE TIRO DEL TRACTOR DE MODO QUE LA DISTANCIA DEL EXTREMO DEL EJE DE LA TDF DEL TRACTOR AL CENTRO DEL PASADOR DEL ENGANCHE DE LA BARRA DE TIRO SEA IGUAL A LA DISTANCIA INDICADA EN EL DIAGRAMA. VER EL MANUAL DEL OPERADOR PARA MAS INFORMACION. 6500440</p>

6500440

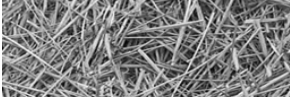

1.4 Shielding

Shields are installed for your protection. Keep them in place, and replace damaged shields.

figure 1.1
PTO driveline shield



CAUTION! NO STEP! DO NOT STEP OR STAND AT THIS LOCATION

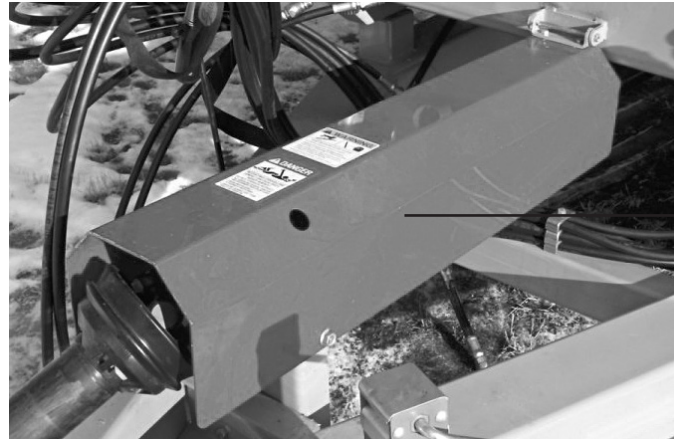

shield

figure 1.2
Orbit motor auger drive shield

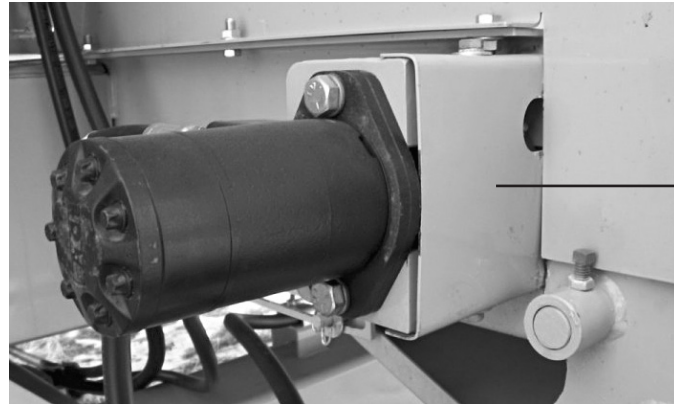

shield

1.5 Safety review section

BEFORE OPERATING

- **Read and follow all instructions contained in:**
 1. This CMF-710 operator's manual
 2. Tractor operator's manual
 3. Decals on the CMF-710



Note: Additional copies of the above mentioned materials can be obtained from your dealer.

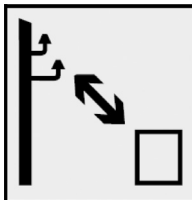

Keep sufficient distance away from electrical power lines.
WARNING: Electrocution is possible when running this machine during an electric storm or heavy fog.

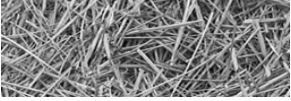

- Allow only responsible, properly instructed individuals to operate your machine. Provide proper training and carefully supervise inexperienced operators.
- Use a tractor which meets the tractor requirement contained within this manual. Additional weights may be necessary.
- Make sure all bystanders and other workers are clear before starting the tractor and CMF-710.
- Make no modifications to the machine unless specifically recommended or requested by DuraTech Industries.
- Check periodically for breaks or unusual wear and make any necessary repairs.
- Securely attach to towing unit. Use high strength, appropriately sized hitch pin with a mechanical retainer.
- If required install P.T.O. safety chain, check local regulations regarding safety chain requirements.
- Be sure that there are no tools lying on or in the CMF-710.
- Because it is possible that your CMF-710 may be used in dry areas or the presence of combustibles, special precautions should be taken to prevent fires and fire fighting equipment should be readily available.



NO SMOKING IN THIS AREA



DANGER! NO OPEN FLAMES IN THIS AREA

- Do not allow anyone to stand between the tongue or hitch and the towing vehicle when backing up to the CMF-710.

DURING OPERATION

- Be sure the tractor operator is the only person riding on the tractor.
- Never allow riders on the machine at any time.



- Keep all bystanders, pets and livestock clear of work area.
- Keep hands and clothing clear of moving parts.
- Never enter the CMF-710 while in operation. Rotating parts can entangle or strike people, resulting in personal injury or death.
- Operate the CMF-710 from the operator's seat only.
- Power takeoff shafts must be locked in place with protective P.T.O. shields in place.

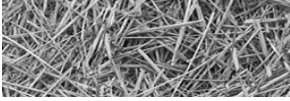

- Do not exceed load capacity of the CMF-710. **(See loading instructions in Section 3.7)**
- Do not clean, lubricate or adjust your CMF-710 while it is moving.
- Periodically clean the equipment to prevent buildup of dry combustible materials.
- Be especially observant of the operating area and terrain – watch for holes, rocks other hidden hazards. Always inspect the area prior to operation.
- Be extra careful when working on inclines.
- Pick the most level route possible when transporting across fields. Avoid the edges of ditches or gullies and steep hillsides.
- Never leave the CMF-710 running unattended.
- As a precaution, always check the hardware on the CMF-710 following every 100 hours of operation. Correct all problems. Follow the maintenance safety procedures.

DURING SERVICE & MAINTENANCE

- Before working on or near the CMF-710 for any reason, including servicing, cleaning, unplugging or inspecting machine, use normal shut down procedures unless instructed differently in this manual.
- Never work on or near the CMF-710 unless engine is shut off, and all power drives and PTO are disengaged. Always follow normal shutdown procedures.
- Check periodically and tighten any loose bolts or connections.
- Where replacement parts are necessary for periodic maintenance and servicing, genuine factory replacement parts must be used to restore your equipment to original specifications. DuraTech Industries will not claim responsibility for use of unapproved parts and/or accessories and other damages as a result of their use. If equipment has been altered in any way from its original design, DuraTech Industries does not accept any liability for injury or warranty.
- If it is necessary to operate the tractor engine indoors for more than a few seconds, be sure to provide enough ventilation to remove the tractor exhaust fumes.
- Hydraulic fluid escaping under pressure can be invisible and have enough force to penetrate the skin. When searching for a suspected leak, use a piece of wood or cardboard rather than your hands. If injured, seek medical attention immediately to prevent serious infection.
- Relieve all pressure in the hydraulic system before disconnecting the hose or performing other work on the system. Make sure all connections are tight and the hose is in good condition before applying pressure to the system.
- Replace all shields and guards after servicing and before moving.



DO NOT PERFORM MAINTENANCE ON THE INTERIOR OF THE TUB DURING WET WEATHER CONDITIONS

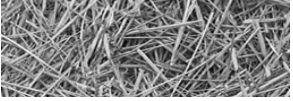

1.6 Towing/road transport

- Use good judgment and drive slowly over rough or uneven terrain.
- Avoid loose fill, rocks and holes; they can be dangerous for equipment operation or movement. Allow for unit length when making turns.
- Be sure tractor brakes are properly adjusted and foot pedals are locked together.
- Check your state laws regarding the use of light, slow moving vehicle signs, safety chain and other possible requirements.

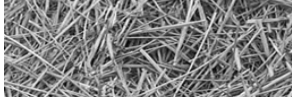

Section 2: Dealer Preparation

2.1 Pre-delivery inspection

Instructions: Before delivering the machine, check the following items carefully and make corrections when necessary. Place an “X” in the box after each item has been checked and found to be acceptable.

- Check machine for missing items or damage in transit.
- Check for loose bolts. Torque to 130-184 ft.-lbs (18-25 kg-m) lubed.
- Check all hydraulic components for leaks or damage.
- Check lug bolts for tightness.
- Check tires for proper air pressure. Tire pressure should be 44 PSI (300 KaPa) maximum. Verify tire markings before inflating.
- Check condition of tire rims
- Check machine for proper lubrication.
- Check all shields for proper installation and condition.
- Check condition of all decals.
- Check all phases of operation.
- Check gearbox oil levels.

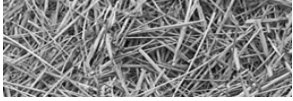

Section 3: Operation

To insure long life and economical operation, we highly recommend the operator of the CMF-710 be thoroughly instructed in the maintenance and operation of the machine. There is no substitute for a sound preventative maintenance program and well trained operator.

Prior to starting the engine of the tractor, we recommend the operator make a visual inspection of the unit. This can be done as the lubrication is being carried out. Any items that are worn, broken, missing or needing adjustment must be serviced accordingly before operating the CMF-710.

General Operating Conditions

Operating Temperature

- This equipment will operate correctly in its intended ambient, at a minimum between +5°C and +40°C.

Relative Humidity

- The equipment will operate correctly within an environment at 50% RH, +40°C. Higher RH may be allowed at lower temperatures.
- Measures shall be taken by the Purchaser to avoid the harmful effects of occasional condensation.

Altitude

- This equipment will operate correctly up to 1000m above mean sea level.

Transportation and Storage

- This equipment will withstand, or has been protected against, transportation and storage temperatures of -25°C to +55°C and for short periods up to +70°C.
- It has been packaged to prevent damage from the effects of normal humidity, vibration and shock.

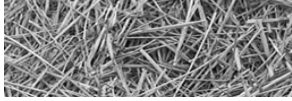

3.1 Pre-starting inspection instructions



WARNING: Before inspecting the machine, use the normal shut-down procedure in Section 3.11.

Check the following:

- Hydraulic components for leaks or damage.



Warning: Hydraulic fluid escaping under pressure can be almost invisible and can have sufficient force to penetrate the skin. When searching for suspected leaks, use a piece of wood or cardboard rather than your hands. If injured, seek medical attention immediately to prevent serious infection or reaction.

- Check for loose bolts, worn or broken parts.
- Lug nuts for tightness. Torque to 130-184 ft.-lbs (18-25 kg-m) lubed.
- Condition of tire rims.
- Tires for proper air pressure. Tire pressure should be 44 PSI (300 KPa) maximum. Verify tire markings before inflating.
- Installation and condition of shields.
- Installations of slow moving vehicle (SMV) sign if required.
- Condition of decals.
- Gearbox oil levels.

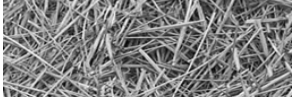

3.2 Setup and Adjustments

3.2.1 Hitch Adjustments

The hitch is adjustable so that the machine is parallel to the ground when attached to the tractor drawbar. This is accomplished by removing the two mounting bolts and reinstalling them with the hitch at the proper height. The distance from the end of the P.T.O. shaft on the tractor to the center of the drawbar hitch pin hole should be 20" (51 cm), and the height from the top of the drawbar to the centerline of the P.T.O, should be 8" (20 cm).

figure 3.1
Hitch adjustments



The hitch pin should be of proper diameter to prevent movement and length to extend through all components of the hitch. The pin should be secured with a hairpin clip or suitable device to prevent the loss of the pin.

3.2.2 Jack

An adjustable jack is provided with the machine to support the hitch when the machine is disconnected from the tractor. The jack must only be used on firm, level ground or similar base to prevent it from sinking.



Warning: Never unhook the CMF-710 with material in tub.

When unhooking the machine remove the jack pin and move the jack from the storage location to the hitch position and reinstall the pin. Crank the jack until the hitch is no longer supported by the drawbar of the tractor. The hitch pin now can be removed.



Warning: Never use the jack without reinstalling the jack pin.

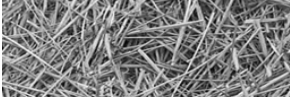

When hooking up the machine, install a proper hitch pin and secure it with a hairpin clip or comparable device, crank the jack until the foot of the jack is fully raised. Remove the jack pin and relocate the jack to the storage location. Reinstall the jack pin.

3.2.3 P.T.O. Shield



Warning: Before lifting the P.T.O. shield be sure to follow the normal shut down procedure. Be certain that the tractor is shut off and all rotating components of the machine have come to a complete stop before lifting shield. Loose clothing is discouraged, and long hair should be restrained whenever working on P.T.O. shafts.

To raise the P.T.O. shield, remove the bolts from the front of the shield and lift the shield. If it does not pivot freely look for build up of debris or other obstructions at the pivot point. Do not force the shield, as damage to the shield may occur.

figure 3.2
Raising the P.T.O.
shield



CAUTION! NO STEP! DO NOT STEP OR STAND AT THIS LOCATION



PTO shield bolt

3.2.4 Hydraulic Cylinder and Valve

All cylinder and valve hose connections should be tight and leak free. If the area near a hose connection becomes oily or dirty, repairs should be made to seal the leak. Hoses should be free of cracks or cuts to ensure safe operation. Cylinder seal kits are available from your dealer to repair a leaky cylinder. Pin connections should be free of excessive wear. If pins become worn they should be replaced. Also check yokes and mounts for cracks and wear.



Warning: Hydraulic fluid escaping under pressure can be almost invisible and can have sufficient force to penetrate the skin. When searching for suspected leaks, use a piece of cardboard or wood rather than your hands. If injured seek qualified medical attention immediately to prevent serious infection or reaction.

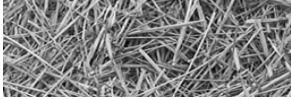

3.2.5 Tires and Rims

Tires should be inflated to 44 PSI (300 KaPa) maximum, and should be free of cuts or cracks. Verify tire markings before inflating. There should also be adequate tread and no visible cords, wires or tread separation. Tires must also be of proper load rating, speed rating and size.

Rims must be free of cracks and rust pitting. Lug bolts must also be tight. Inspect the area around the lug bolts. Lug nuts need to be torqued to 130-184 ft.-lbs (18-25 kg-m) lubed. If rust develops this is a sign of loose lug bolts. Check wheel bearings and seals, replace and grease as use requires.

3.2.6 Knives

Your new CMF is setup with seven knives on each auger, the top two knives in each auger have two positions, in or out. When processing tough hay the knives should be in the out position to better attack the long stem hay. Having the knives in the out position increases the horsepower requirements. Alternatively, knives can be removed if the ration does not require much processing and/or over-processing is a possibility. Ingredient condition and rations will determine the optimum layout.

figure 3.3
Knife position
adjustments,
knives in the 'outside'
position



**DANGER! KEEP HANDS AWAY
FROM CUTTING PARTS**

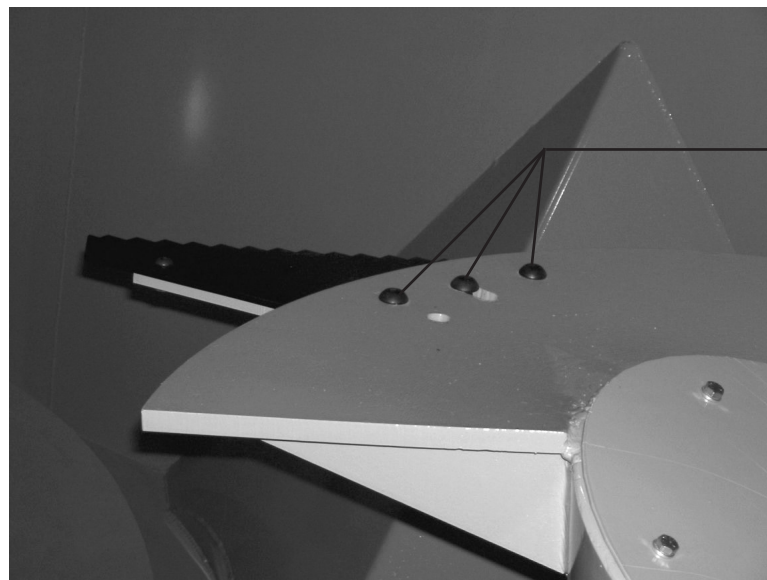

knife position
adjustment bolts

3.2.7 Vertical knives

The purpose of the vertical knives is to create restriction to the flow of material around the tub and provide a shear point for the auger knives. The further into the tub the vertical knives are set the shorter the final stem length will be. The vertical knives also can affect the horsepower demand, which may be important depending on tractor size. Start using your CMF with the knives at neutral or one hole in and adjust as necessary.

vertical knife adjuster



figure 3.4
Vertical knife
adjustments, shown
with knife in the fully
engaged position

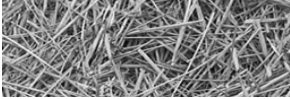

3.2.8 Free motion automatic clutch

Torque protection is built into the PTO driveline with two free motion automatic clutches. These clutches are located on each driveline immediately before each gearbox.

When overload occurs the clutch disengages and does not reengage until the driveline speed is reduced to near zero.

The clutch makes a loud click when it disengages.



3.2.9 Scale Indicator

The indicator for the four-point scale should be mounted on the indicator mount located on top of the main conveyor. The mount can be mounted in the left or right side of the conveyor. The indicator is powered by a 12 volt battery located under the tub on the left side of the frame. **SEE OPERATOR'S MANUAL FOR THE DIGISTAR EZ-2000 SCALE INDICATOR FOR OPERATING INSTRUCTIONS.**

figure 3.5
EZ-2000 scale indicator

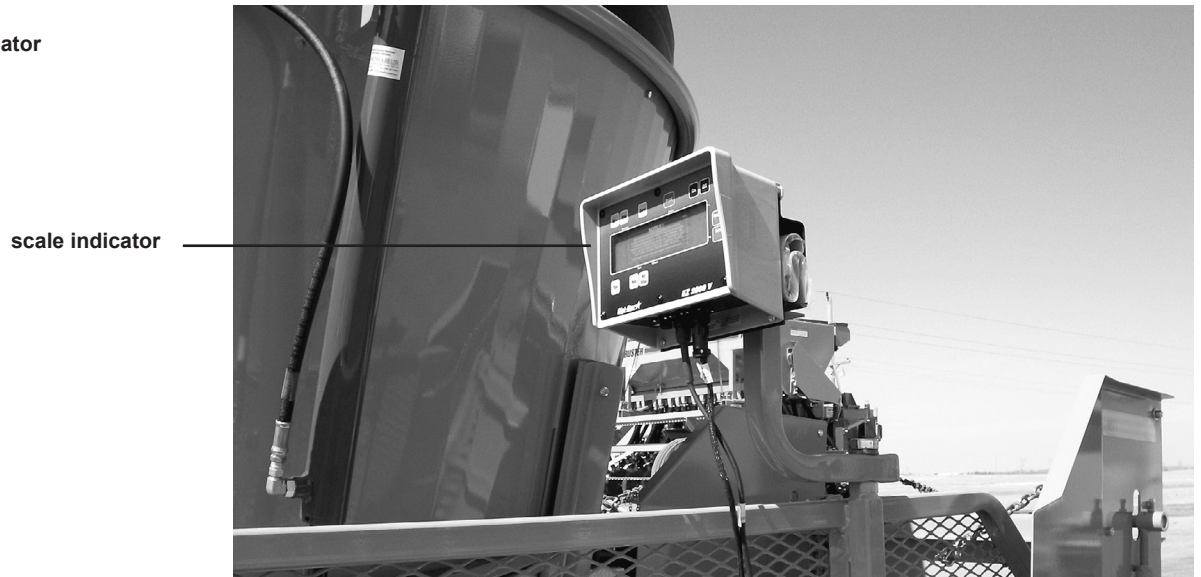

3.2.10 Two-Speed Gearbox (Option)

The two-speed gearbox is available on the CMF-710 for operators who want more control of their mixing speeds, want to reduce overall horsepower requirements, or prefer to turn off mixer while transporting a loaded mixer. The two-speed gearbox has two speeds, low and high. (See Section 6.4)

3.2.11 Extension Conveyor Spouts (Option)

Spouts are available with or without magnets. Spouts are adjustable in three hole positions on sides. Point spout down further when running the conveyor extensions at higher angles to avoid material build up on the end of the conveyor.

When running conveyor at lower angles, direct spouts so that the magnets are positioned further into the flow of material. Pictures of available spouts can be found in Sections 6.2 and 6.3.

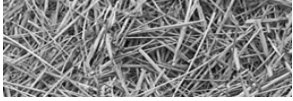

3.2.12 Setting Chain Tensions on Conveyors

Dogleg Conveyor

Set tension while conveyor is running. Turn tensioning nut to compress the spring into the cup until either the nut reaches the cup or the spring is fully compressed. Do not tension beyond full compression of the spring. Tension other side, and then recheck the first one adjusted. Continue until both springs are at full compression, lock with jam nuts. Monitor the chain tension by watching the relation of the nut to the cup. As the chain assembly wears, the nut will move away from cup via the spring. If the chain assembly becomes too loose, it will jump teeth on the sprocket potentially causing misalignment and chain assembly failure.

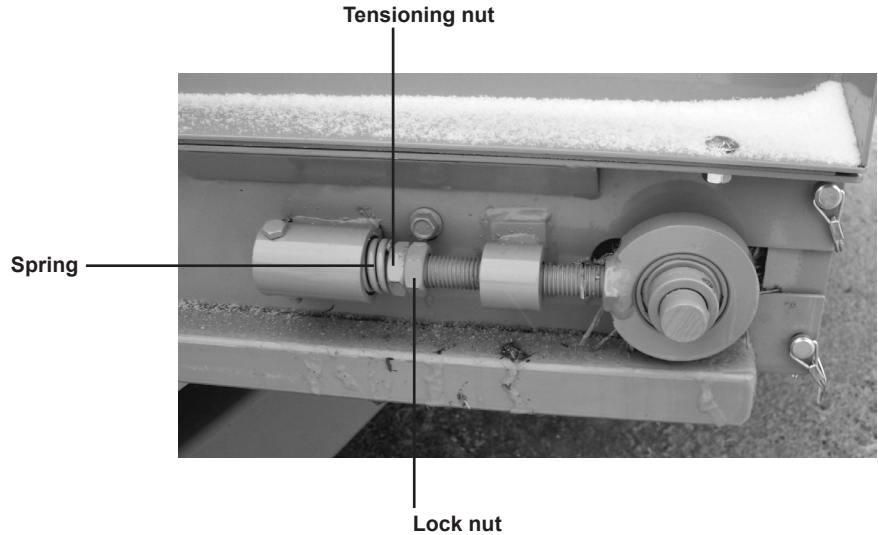

Main Front Conveyor w/hydraulic raise extension

Using a tape measure or ruler, set the tensioning shaft the same distance from the end of the conveyor frame on both sides. Go to the center of the conveyor and lift up on the centermost slat where the front chain is connected. Operator should be able to comfortably lift the slat off the deck 1". This should take about 15-20 lbs of force. Over-tensioned chain assemblies may cause chain coupler or shaft failures. Under-tensioned chain assemblies may become misaligned. Keep the idler shaft bearings equidistant from the conveyor frame. Should one chain become excessively worn, replace them both with new chains.

The hydraulic extension conveyor should be tensioned using the same guidelines.

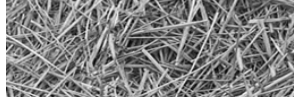

3.3 Hitching the CMF-710



Warning: Do not operate the CMF-710 unless the tractor complies with the following requirements:

- Tractor has a minimum of 125 horsepower. (without two-speed option)
- Tractor has rollover protective structure and seatbelts.
- Tractor's hydraulic system has at least (2) two-way valves, and a minimum flow of 8 GPM @ 1500 psi (103 bars).
- To assure adequate braking and steering control while in transport, the tractor must have a weight greater than or equal to 2/3 weight of the CMF-710 and any mix it will transport at speeds more than 10 MPH (16 kph). ((Max CMF 13,660 lbs. + max load 18,340 lbs) x (0.67) = 21,440 lbs.) ((Max CMF 6,196 kg + max load 8,319 kg) x (0.28) = 4,064 kg)
- 1000 rpm P.T.O.

To hitch the CMF-710 to the tractor, perform the following steps:

1. Adjust the tractor drawbar so that the distance from the end of the P.T.O. shaft on the tractor to the center of the drawbar hitch pin hole should be 20" (51 cm) when using a 1-3/4", 20 splined P.T.O. When using a 1-3/8", 21 splined P.T.O., the draw hitch pin hole should be 16" (41 cm) and the height for the top of the centerline of the P.T.O. should be 8" (20 cm). Refer to figures 3.6.1 and 3.6.2

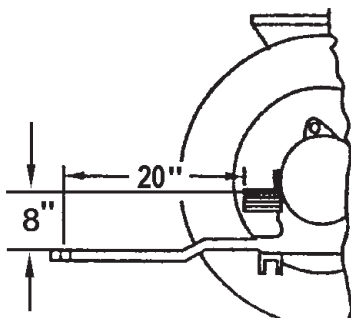

figure 3.6.1
Safe P.T.O. distance
1-3/4", 20 splined P.T.O.

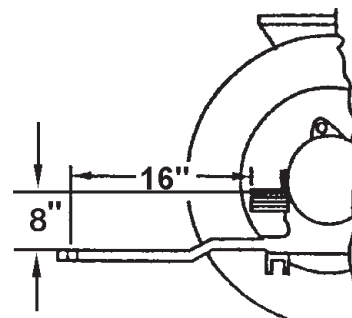
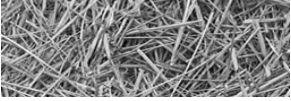

figure 3.6.2
Safe P.T.O. distance
1-3/8", 21 splined P.T.O.

- 2a. Hitch the CMF-710 to the tractor drawbar. Adjust the hitch so the machine is parallel with the ground.
 - 2b. If the CMF-710 is equipped with a two-speed gearbox, adjust the hitch to minimize the P.T.O. shaft angle.
3. The hitch pin should be sized to prevent excessive movement, and should extend through all components of the hitch. The pin should be secured with a hairpin clip or suitable device to prevent the loss of the pin.
 4. Raise the jack. Pull the lock pin and store in transport position.
 5. Attach the P.T.O. shaft to the tractor P.T.O. shaft. Depress coupling and slide the coupling onto the splined shaft. Make sure the spring loaded safety catch is properly seated.



6. This machine is set up to operate on 1000 rpm only!
7. If required, install the safety chain. Check local regulations regarding safety chain requirements. Refer to figure 3.7

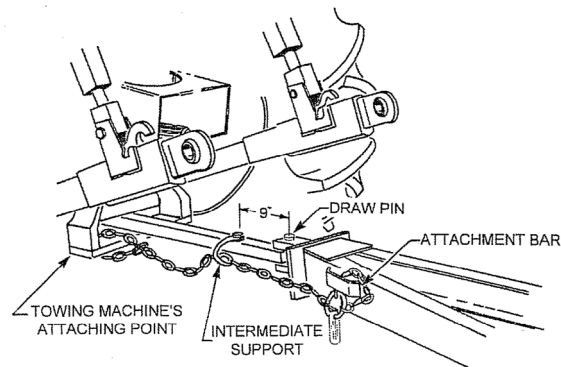

figure 3.7
Safety chain installation

8. Connect the two hydraulic hoses from the hydraulic door cylinder to one set of hydraulic couplers on the tractor. Connect the two hydraulic hoses from the discharge conveyor to the second set of hydraulic couplers on the tractor. Connect the two hydraulic hoses from the extension conveyor to the third set of hydraulic couplers on the tractor.
9. If equipped with a rear door and/or second extension conveyor, connect the two hydraulic hoses from each to the fourth and/or fifth hydraulic couplers on the tractor.

3.4 Unhitching the CMF-710

To unhitch the CMF-710, perform the following steps:



Warning: Never unhook the CMF-710 with material in tub.

1. Follow normal shut-down procedure.
2. Lower jack and secure. Raise the tongue off the tractor draw bar.
3. Place wheel chocks under wheels to keep from rolling.
4. Detach the P.T.O. shaft from the tractor.
5. Cycle the hydraulic control levers to release any pressure in the hydraulic hoses.
6. Detach the hydraulic hoses.
7. Remove the safety chain, if installed.
8. Remove the hitch pin.

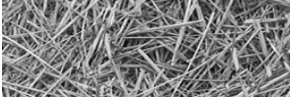

3.5 Operation precautions and instructions

- Make sure there are no bystanders in the way.
- Before loading, run the mixer empty and check all operations.
- Do not overload the mixer. Maximum load is 18,340 lbs. (8,319 kg) Maximum load is determined by weight, not volume.
- Be sure all shields are in place before operation.
- Use common sense when operating.
- Never attempt to climb on the CMF while the tractor is running.

3.6 Starting the machine

1. Park machine on a hard level surface keeping the driveline as straight as possible.
2. Close the mixer door.
3. If the scale indicator is not at zero, re-zero indicator per the scale indicator manufacturer's instructions.
4. If equipped with two-speed gearbox option, select mixing gear desired.
5. Engage the tractor PTO and increase engine RPM to desired mixing speed.

3.7 Loading and processing

1. Load baled products and materials that require processing first. The center core of round bales will be the toughest to process. Allow enough processing time to adequately process roughage.
2. Set vertical knives per adjustment section.
3. Do not over process as processing continues through the mixing stage.
4. Load silage and/or other high moisture products next.
5. Load dry ingredients.
6. Load liquid supplements last.
7. Allow three to four minutes of mixing time after last ingredient.
8. ALL PROCESSING AND MIXING TIMES WILL VARY.
9. Do not overload the CMF, maximum capacity is 18,340 lbs. (8,319 kg) Maximum load is determined by weight, not volume.

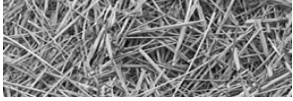

3.8 Unloading

To unload the CMF-710, perform the following steps:

1. If possible, move the mixer to the unloading site while finishing the mixing stage to avoid the need for loaded PTO start-up.
2. Align CMF with bunk and lower the conveyor extension to desired angle (if equipped).
3. Engage the chain conveyor; chain speed is controlled using the auxiliary valve flow control on the tractor.
4. If the augers are not already engaged, engage the PTO.
5. Open the tub door and proceed along the bunk. Engine speeds around 1500 rpm are usually adequate when the tub is full, however engine should be run at rated speed to clean out the tub and provide even feed flow when the tub is near empty. If equipped with two-speed gearbox, turn off mixer and shift to high speed and re-engage to achieve maximum clean out RPM. Most new tractors have P.T.O. brakes which will require the tractor to be turned off before the two- speed can be shifted.

3.9 Storing the CMF-710 mixer/feeder



Warning: When preparing machine for storage, use normal shut-down procedure.

To prepare the CMF-710 for storage, perform the following steps:

1. Clean all mud, dirt, grease and other foreign material from the exterior and interior of the machine. Wash the complete machine. To inhibit rusting repaint places where bare metal is exposed.
2. Place the jackstand in the down and in locked position. Place wheel chocks under wheels if needed to keep machine from rolling. If possible, store the machine in a dry, protected place. (If it is necessary to store the machine outside, cover it with waterproof canvas, plastic, or other suitable protective material.)
3. Coat exposed lift cylinder rods with grease. Oil chains on conveyors. Lubricate thoroughly according to lubrication instructions. Repack wheel bearings.
4. Check the machine for any worn or broken parts. By ordering parts now, you will avoid delays when it is time to remove the machine from storage. When ordering parts always specify machine serial number and the part number of the replacement part. Part numbers can be found in the parts section of this manual.

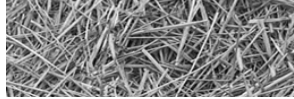

3.10 Removing the CMF-710 from storage

To remove the CMF-710 from storage, perform the following steps:

1. Remove all protective coverings.
2. Remove blockings from under the CMF-710. Check tire pressure.
3. Lubricate machine in accordance with lubrication instructions found in this manual.
4. Check the conveyor chain tension.
5. Check all hydraulic hoses for deterioration and, if necessary, replace. Tighten any loose bolts, nuts and hydraulic fittings.
6. Follow pre-starting inspection instructions.

3.11 Normal shut-down procedure



Warning: For your safety and the safety of others, you must use the following normal shut-down procedure before leaving the tractor controls unattended for any reason, including servicing, cleaning, or inspecting the CMF-710. A variation of the following procedure may be used if so instructed within this manual or your tractor manual or if an extreme emergency requires it.

1. Disengage P.T.O.
2. Place transmission in park or set park brake.
3. Shut off machine and remove key.
4. Wait for all movement to stop.
5. Engage tractor park brake, turnoff and remove key engine prior to entering the tub and/or making any adjustments to CMF.

3.12 Light Kit

figure 3.8
light kit for the CMF-710



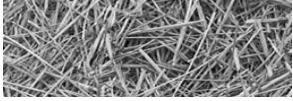

Section 4: Lubrication

The operator should make a check of all grease fittings on the unit before beginning to operate it so as to become familiar with their location and correct service schedule.



Warning: Use normal shut-down procedure (Section 3.11) before lubricating the machine.

4.1 Lubrication

Use only a high quality, #2 multi-purpose grease when lubricating the unit. Make sure all fittings and the nozzle of the grease applicator are clean before applying the grease. If grease fittings are missing, replace them immediately.

Lubricate with grease every ten (10) hours of operating time.

1. P.T.O. universal joints – 8 places
 - 1a. As many as seven (8) pumps of grease are required to purge all cross and bearing lube point with fresh grease.

2. Telescoping shafts – 2 places
 - 2a. Telescoping members require enough grease to maintain a smooth sliding action. When telescoping members become contaminated with dirty grease, they should be inspected and cleaned to insure smooth operation.

 - 2b. Shield components should be lubed and inspected to insure all components are in working condition or are replaced if damaged. A properly maintained shield will inhibit dirt from contaminating telescoping members.

3. P.T.O stand bearing – 1

Lubricate with grease every fifty (50) hours of operating time.

4. Conveyor bearings - 2
5. Extension conveyor bearings – 2 each
6. Automatic clutches – Two places – 1 pump only. *Be careful **not** to over grease.*
7. Auger grease lines - 2

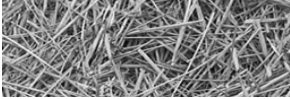
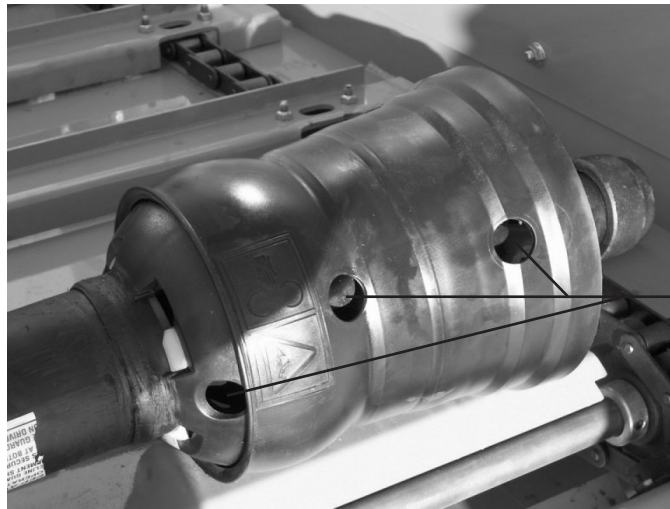

figure 4.1
P.T.O. Universal joint
(1 of 8)



P.T.O. universal joint
lubrication zerk

figure 4.2
P.T.O. Universal joint
(2, 3, & 4 of 8)



P.T.O. universal joint
lubrication zerks

figure 4.3
P.T.O. Universal joint
(5 of 8), and P.T.O stand
bearing (1 of 1)



P.T.O. universal joint
lubrication zerk

P.T.O stand bearing
lubrication zerks

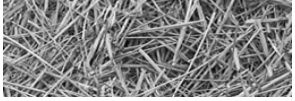
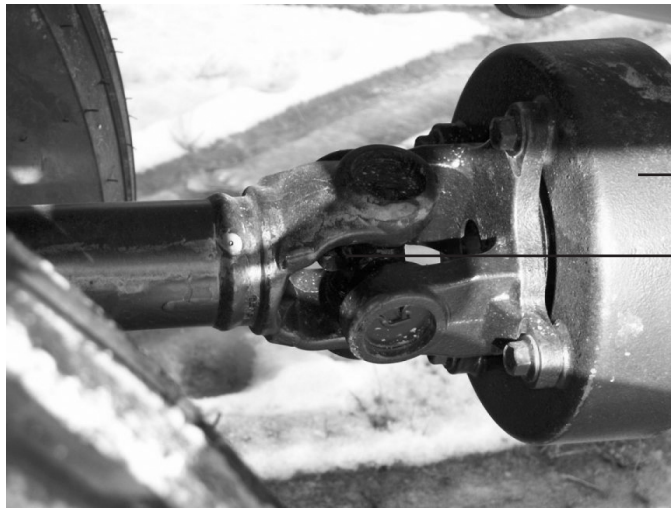

figure 4.4
P.T.O. Universal joint
(6 of 8), and automatic clutch



automatic clutch

P.T.O. universal joint
lubrication zerk

figure 4.5
P.T.O. Universal joint
(7 of 8)



P.T.O. universal joint
lubrication zerk

figure 4.6
P.T.O. Universal joint
(8 of 8), and automatic clutch



automatic clutch

P.T.O. universal joint
lubrication zerk

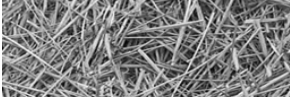
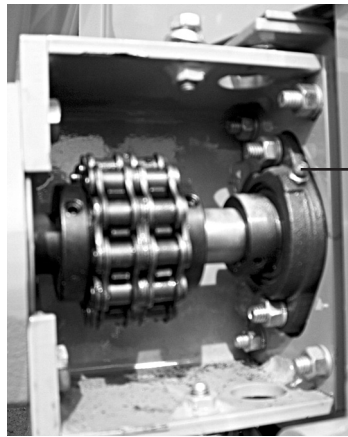
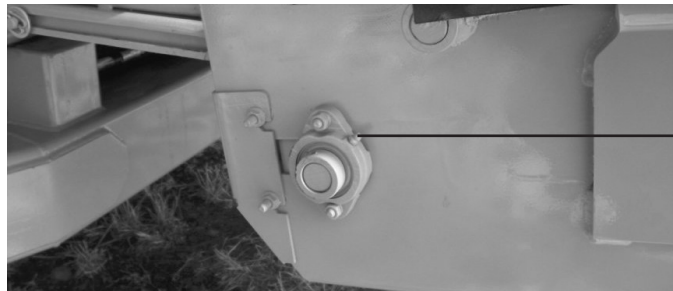

figure 4.7
Conveyor bearings
lubrication point (1 of 2)



conveyor bearings
lubrication zerk

figure 4.8
Extention conveyor bearings
lubrication point (1 of 4)



extention conveyor bearings
lubrication zerk

figure 4.9
Telescoping P.T.O. shaft

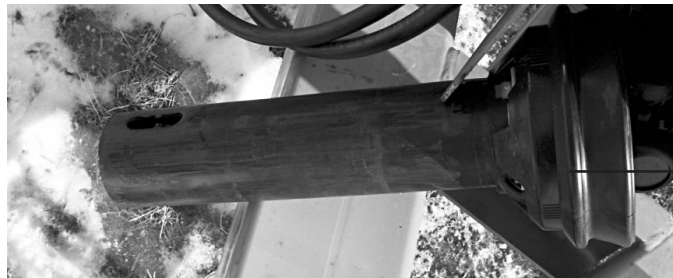

telescoping shaft

figure 4.10
Auger grease lines



auger grease lines
lubrication zerk

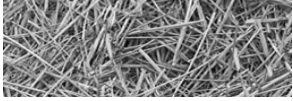

4.1 Lubrication cont.

Wheel bearings: repack annually

Gearbox: Grease 20-30 pumps every 250 hours (each gearbox), located on the bottom of the tub in front of the left tires.

Chains: Oil conveyor chains every 15 hours.

When to change oil in gearboxes:

- After the first 50-100 hours of operation, drain initial oil, preferably when box is warm. There after oil should be changed every 1500 hours or 12 months, whichever comes first. If machine usage is severe or more than 10 loads per day, it is advisable to change the oil every 1000 hours or 6 months. Inspect and wash oil reservoir breather cap as needed. Air dry before reinstalling. **Fill each gearbox with approximately 5 ½ gallons (21 L) of EP150 or 80w-90 GL-5 weight Gear Lube. RR-USA recommends using synthetic oil in their gearbox.** Monitor the oil level in the reservoir daily. Oil level should be in the middle of the sight gauge. The working temperature must not exceed (90 degrees C) 194 degrees F max. Proper lubrication is essential for efficient running and long life of the unit as a whole. It is also important to select the correct type of oil to ensure the long life of the gear reducer.



Do not dispose of gearbox oil in the municipal waste stream

Procedure for changing oil in gearboxes (see chart 4.1 on the following page):

1. Remove magnetic drain plug from the bottom of the right angle gearbox and clean the magnet if it has any metal on it. Return plug to the gearbox before filling.
2. Disconnect the lube lines from the top of the gearboxes at the tee fitting. Disconnect the other lube lines from the bottom of the gearboxes at the other tee.
3. To fill, connect (-8)3/4" MJIC fitting to hose connected to the right angle box and place overflow hose in a pan. Pump oil into the gearbox until it runs out of the overflow hose. Reconnect hoses to the correct fitting. Repeat for rear gearbox.
4. Fill reservoir and continue to monitor reservoir levels during operation so that oil remains half-way up in sight gauge or higher, allow for more expansion in warmer climates.
5. Two-speed gearbox should be half full of oil so that oil is present in sight gauge. Follow same maintenance schedule and use the same oils as recommended above for vertical gearboxes.
6. Any brand of 80w-90 gear oil with a GL-5 rating may also be used; **RR_USA recommends use of synthetic oils.**

Recommendation: Prior to starting each day it is advisable to check the oil level of gearboxes at the sight gauge.

Contact information for:

ConocoPhillips Lubricants: Telephone: 1-800-255-9556 (Technical Hotline)
Email: conocolubricants@conophillips.com

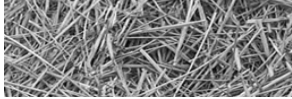
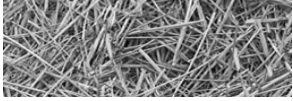

chart 4.1
lubrication chart for reduction gears

Ambient Temperature	-4 F - +41 F -20 C - +5 C	-41 F - +104F +5 C - +40 C	+86 F - +149 F +30 C - ++65 C	+104 F- +149 F +40 C - +65 C
Viscosity				
ISO VG	100	150	220	320
E/50 C	7.3	10.8 -12.5	15 -18	22 - 26
AGIP	BLASIA 100	BLASIA 150	BLASIA 220	BLASIA 320
BP-MACH	ENERGOL	ENERGOL	ENERGOL	ENERGOL
	GR-HP100	GR-HP150	GR-HP220	GR-HP320
CASTROL	ALPHA SP 100	ALPHA SP 150	ALPHA SP 220	ALPHA SP 320
CHEVRON	NL GEAR	NL GEAR	NL GEAR	NL GEAR
	COMPOUND	COMPOUND	COMPOUND	COMPOUND
	100	150	220	320
ELF	REDUCTELF SP 100	REDUCTELF SP 150	REDUCTELF SP 220	REDUCTELF SP 320
ESSO	SPARTAN EP 100	SPARTAN EP 150	SPARTAN EP 220	SPARTAN EP 320
FINA	GIRAN 100	GIRAN 150	GIRAN 220	GIRAN 320
IP	MELLANA 100	MELLANA 150	MELLANA 220	MELLANA 320
MOBIL	----	MOBILGEAR 629	MOBILGEAR 630	MOBILGEAR 632
SHELL	OMALA EP 100	OMALA EP 150	OMALA EP 220	OMALA EP 320
TOTAL	CARTER EP 100	CARTER EP 150	CARTER EP 220	CARTER EP 320

4.2 General appearance

Clean all mud, dirt, grease and other foreign material from the exterior of the machine. Wash the entire machine. Repaint places where bare metal is exposed.



Section 5: Troubleshooting

chart 5.1
Troubleshooting chart

Problem	Cause	Remedy
1. Spillage over tub	1. Vertical knives are in too far.	1. Pull knives out one notch at a time until material stops spilling.
	2. Auger speed is too fast.	2. Slow engine speed
	3. Tub is overfilled	3. Wait longer while processing first bale, before adding more hay or other ingredients. Allow more time to process bulky materials. 4. Park on level ground.
2. Augers stopped turning	1. Automatic clutch disengaged because of shock loading	1. Disengage tractor PTO. Wait till driveshaft stops and reengage PTO. Clutch automatically reengages when driveline slows to near zero rpm. May need to shift gearbox to low.
	2. Verify two-speed is engaged	2. Check lever position on two-speed gearbox, Forward -high speed Middle -neutral Back -low speed
3. Conveyor does not move	1. Conveyor plugged	1. Look for obstruction
	2. Chains too tight	2. Reduce chain tension
	3. Hoses uncoupled.	3. Make sure hoses are coupled properly.
4. Conveyor plugged/spillage at transition to extension	1. Extension conveyor running at too steep of an incline	1. Run extension conveyor at lowest height possible to reach the necessary bunk height.
5. Ration over processed	1. Processing continues through mixing stage	1. Add secondary ingredients that don't require processing to the batch sooner.
	2. Too many knives	2. Take knives out.
	3. Vertical knives in too far	3. Pull vertical knives out further,
	4. Auger speed too fast	4. Reduce tractor engine rpm
6. Ration under processed	1. Not enough knives on the augers	1. Add knives
	2. Knives are dull	2. Replace knives
	3. Auger speed not fast enough	3. Increase auger speed, careful not to cause spillage.
	4. Vertical knives not in far enough	4. Push vertical knives in one notch.
7. Scale does not power up	1. Battery not charged	1. Charge the battery/replace if necessary.
	2. Loose battery connection	2. Tighten/clean connections at battery post.
	3. Battery power cable damaged	3. Repair/replace cable.
(Consult scale manufacturer's manual for all other information)	For 24 hour Tech service, Go to digi-star.com or call 1-800-225-7695	
8. Door is loose/does not seal	1. Door clamps out of adjustment	1. Readjust door clamps

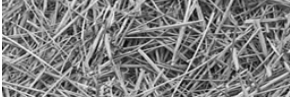

Section 6: Options

6.1 Rear bay door

figure 6.1
Optional rear door

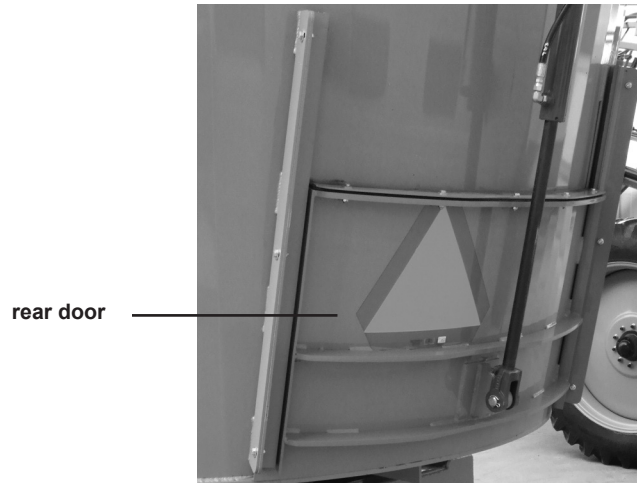

6.2 Magnetic extension spouts

figure 6.2
Magnetic extension spout



6.3 Non-magnetic extension spout

figure 6.3
Non-magnetic extension spout

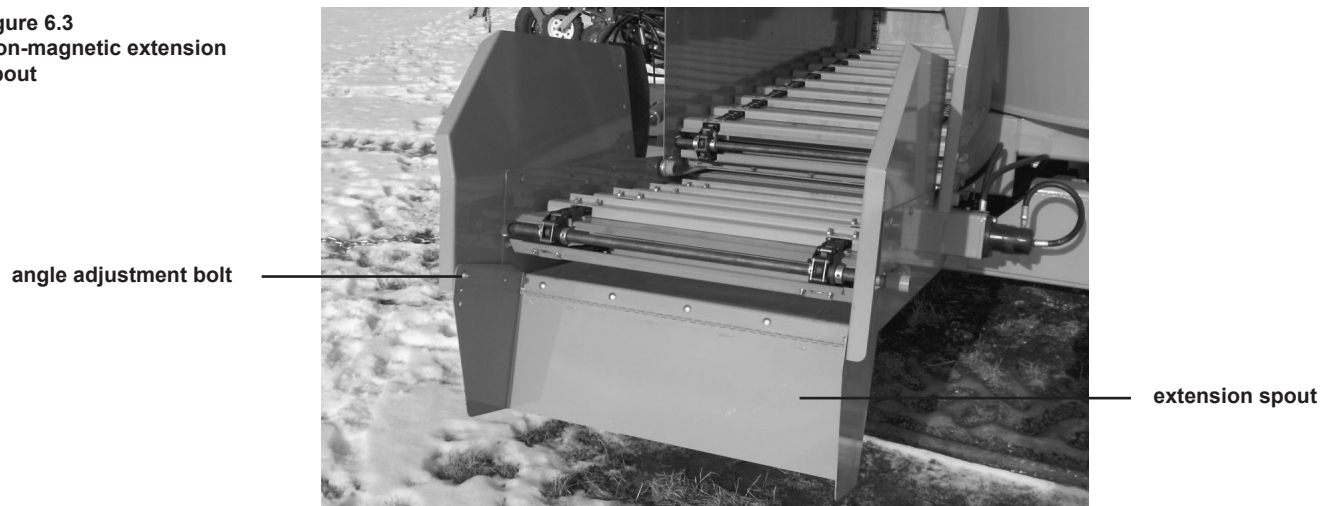

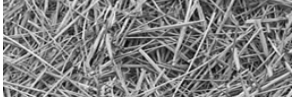

6.4 Two-Speed Gearbox

figure 6.4
Two speed gearbox in
low speed position

speed selector
low speed position

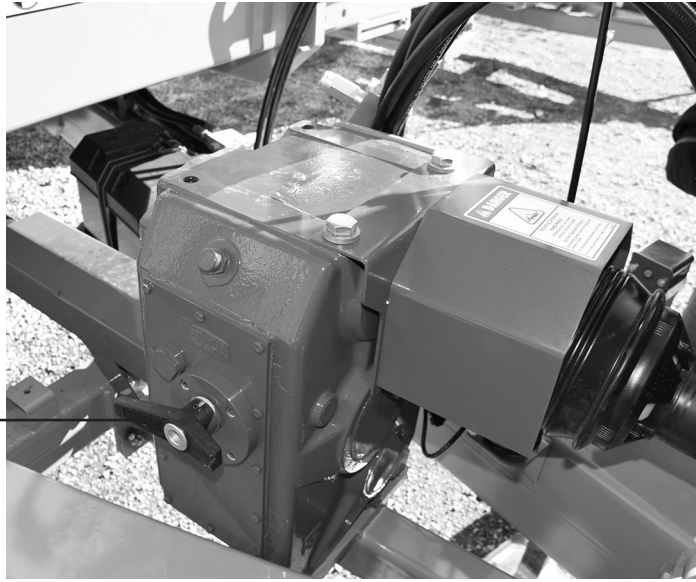

figure 6.5
Two speed gearbox in
high speed position

speed selector
high speed position



figure 6.6
Two speed gearbox in
neutral speed position

speed selector
neutral speed position

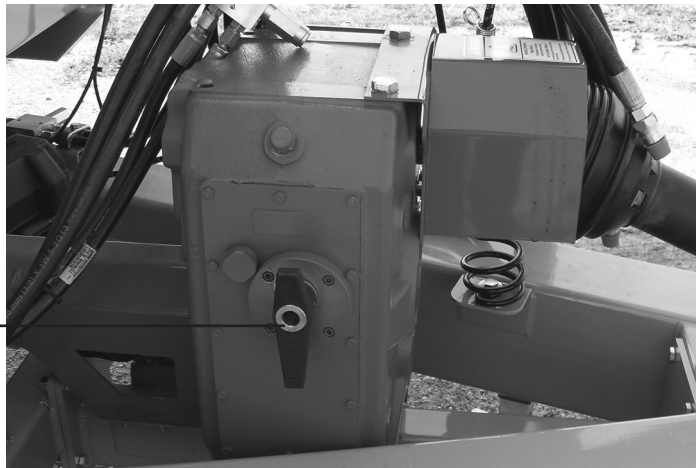

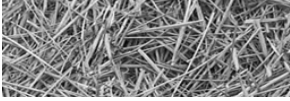

6.5 Dogleg Conveyor



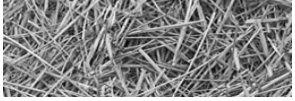

Section 7: Maintenance

7.1 Welding Procedure

CMF-710 welding procedures for machines with a weight scale

Precautions are required for welding on machines with electronic components. Electronic components including but not limited to: electronic scales.

Proper welding procedures are necessary with in order to avoid damage to the components, their sensors, and associated components.

When possible, remove the parts to be welded from the machine.

If not possible to remove the parts, follow the following procedure:



Note: Do not ground the welder to electrical components listed above, sensors, or wiring. Improper grounding can also damage bearings of hydraulic components. Clamp the ground cable from the welder to the part that will be welded. Place the clamp as close as possible to the weld. This will help reduce the possibility of damage.

1. Unhitch the CMF-710 from the tractor.
2. Disconnect the connectors from the electronic scale. Move the connectors to a position that will not allow the connectors to accidentally move back and make contact with any of the pins.
3. Connect the welding ground cable directly to the part that will be welded. Place the ground cable as close as possible to the weld in order to reduce the possibility of welding current damage to bearings, hydraulic components, and electrical components.



Note: If the electrical/electronic components are used as a ground for the welder, or electrical/electronic components are located between the welder ground and the weld, current flow from the welder could damage the components.

4. Protect the wiring harnesses and hydraulic lines from welding debris and spatter.
5. Use standard techniques to weld the materials.

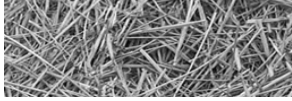

Appendix A: Warranty

DuraTech Industries International Inc. warrants to the original purchaser for one year from the purchase date that this product will be free from defects in material workmanship when used as intended and under normal maintenance and operating conditions. This warranty is limited to the replacement if any defective part or parts if DuraTech Industries is notified within thirty (30) days of failure.

DuraTech Industries International Inc. uses RR planetary gear boxes in all CMF machines. The planetary gear boxes carry a two year parts and labor warranty through DuraTech Industries International Inc.

BIMA two speed gear boxes are covered under the DuraTech Industries International Inc. standard one year warranty.

This warranty shall become void if in DuraTech Industries International Inc.'s judgement the machine has been subject to misuse, negligence, alterations, damaged by accident or lack of required maintenance, or if the product has been used for a purpose for which it was not designed for.

All claims for warranty must be made through the dealership which originally sold the product and all warranty adjustments must be made through the same.

This warranty does not apply to tires, bearings, or any other trade accessories not manufactured by DuraTech Industries International Inc.'s. Buyer must rely solely on the existing warranty, if any, of these respective manufactures.

DuraTech Industries International Inc. shall not be held liable for damages of any kind, direct, contingent, or consequential to property under this warranty. DuraTech Industries International Inc. cannot be held liable for any damages resulting from causes beyond its control. DuraTech Industries International Inc. shall not be held liable under this warranty for loss of crops or rental costs or any expense or loss for labor or supplies.

DuraTech Industries International Inc. reserves the right to make changes in material and/or design of this product at any time without notice.

All other warranties made with respect to this product, either expressed or implied, are hereby disclaimed by DuraTech Industries International Inc.

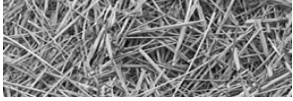

Appendix B: CMF-710 Specifications

General specifications

Max. Weight	13,660 LBS (6,196.07 kg)
Overall length, including trailer	22'-2 11/16" (6.774 m)
Overall width	10'-1 1/2" (3.086 m)
Tractor P.T.O speed ... (1-3/8" 21 spline)	1000
Minimum horsepower required	125
Mixing capacity, cu. ft.	710 cu. ft. (20.1 cu. m)
Max. Gross Weight	32,000 LBS (1,414.96 kg)
Tires – size	14L-16.1-12 PLY
Loading height with extensions	10'-2 3/4" (3.118 m)
Loading height without extensions	9'-7" (2.921 m)

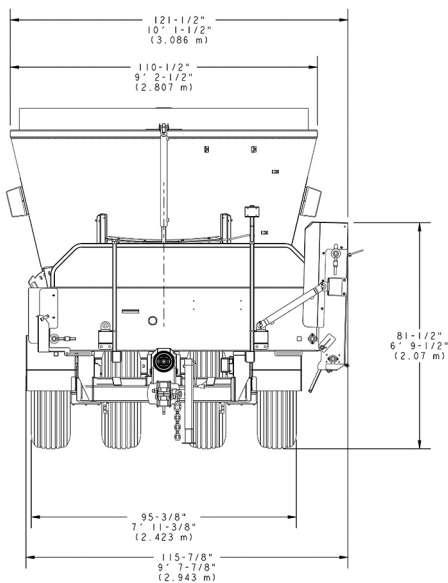
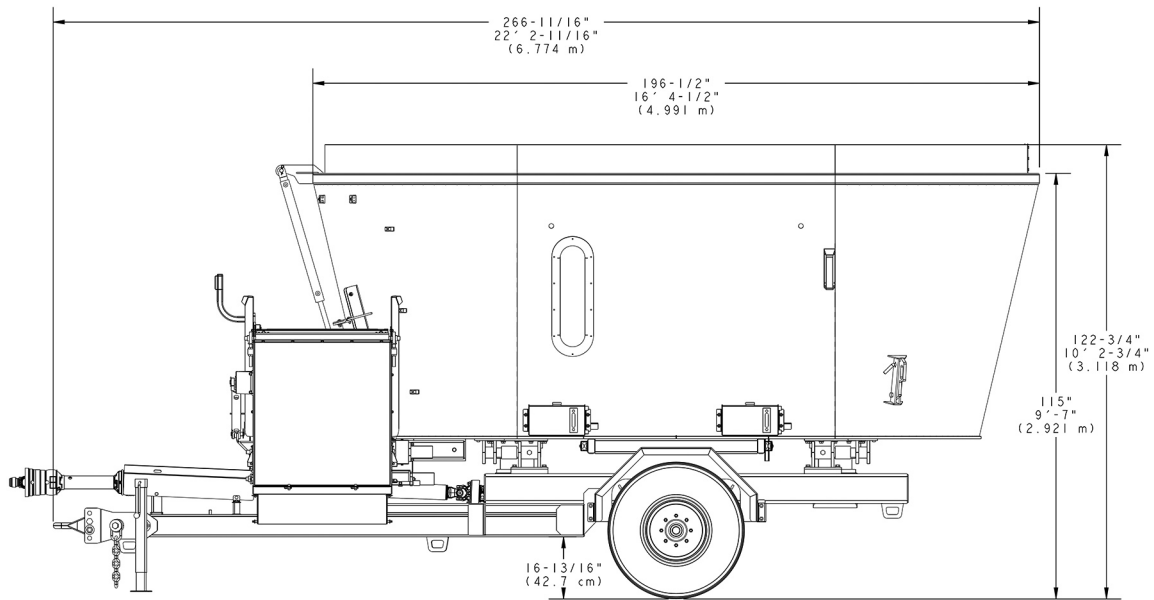

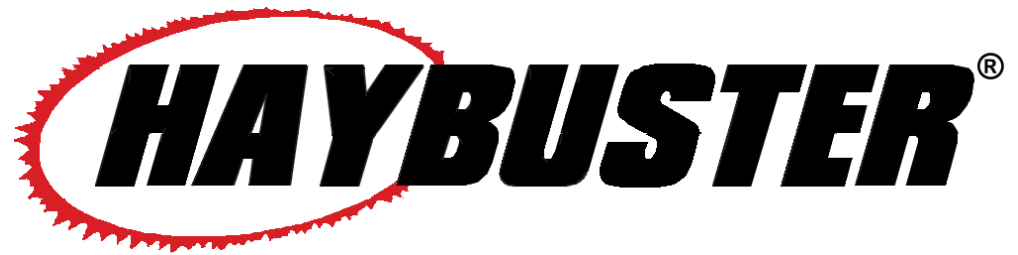
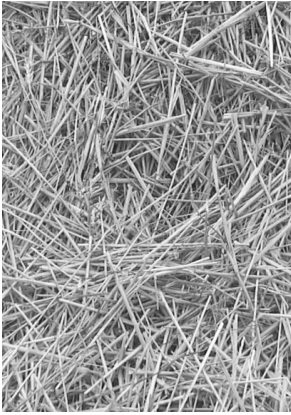

CMF-710™ VERTICAL MIXER

Part 2: Parts Reference

TUB ASSEMBLY COMPLETE

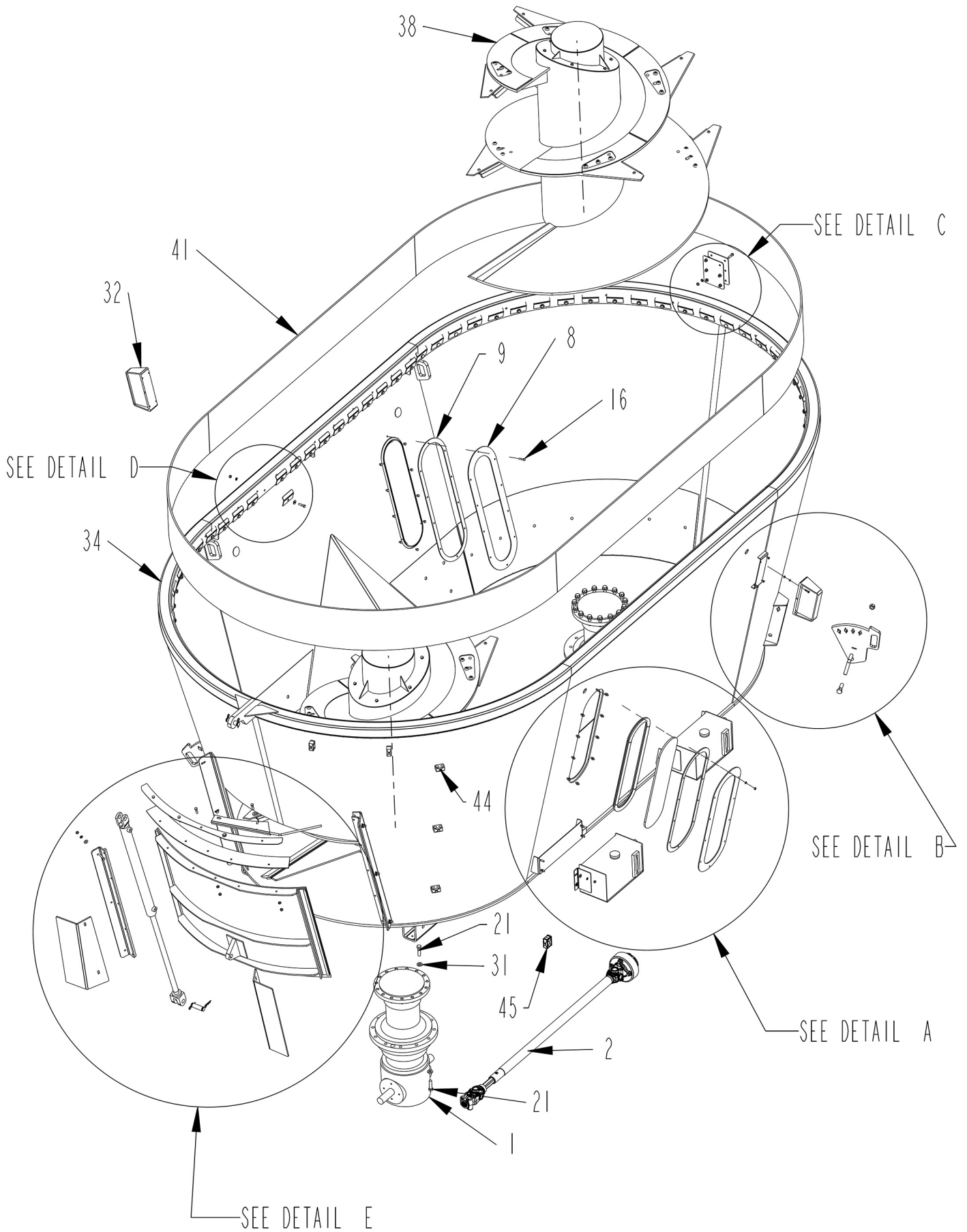

TUB ASSEMBLY DETAIL A

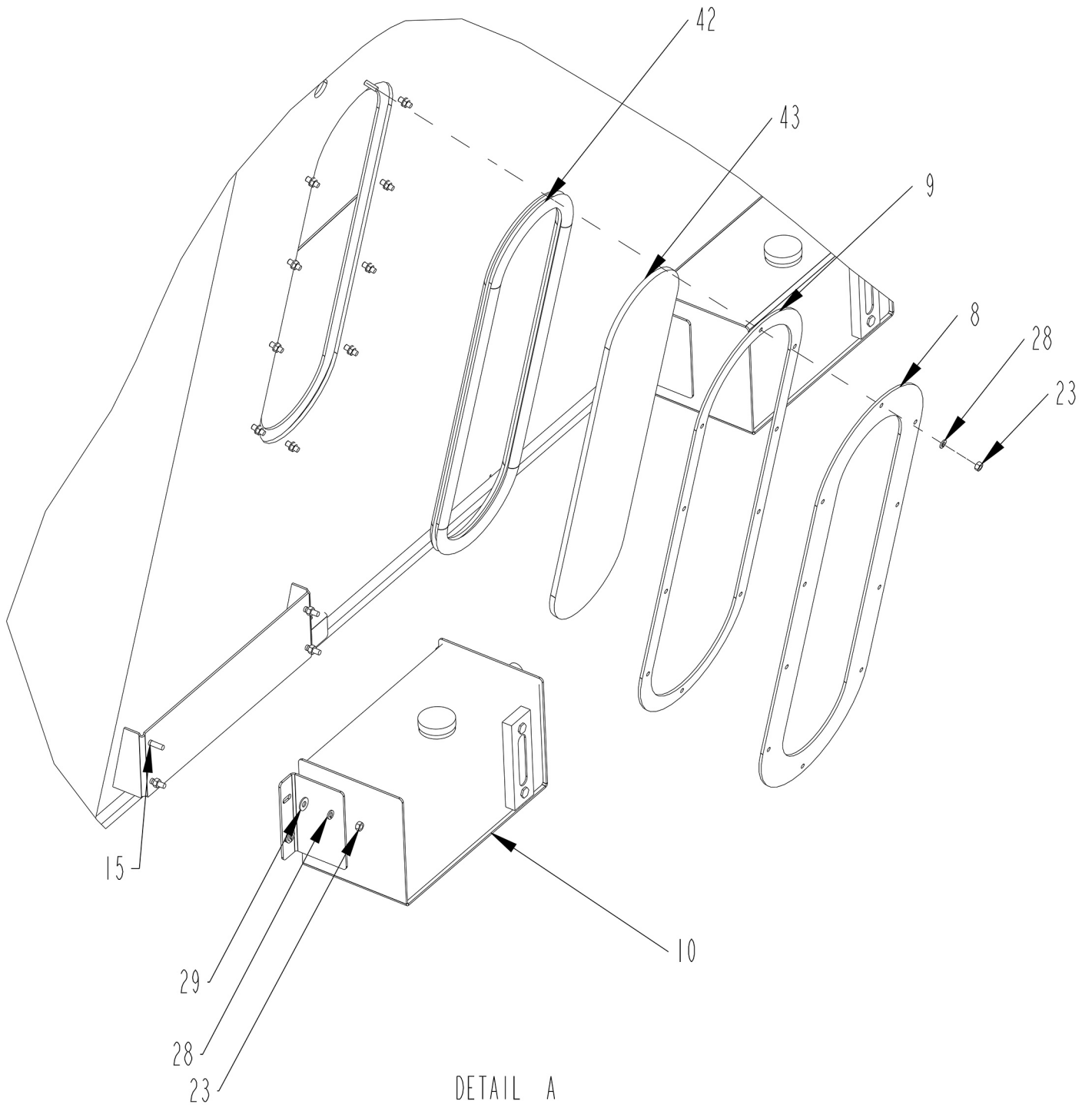

DETAIL A

TUB ASSEMBLY DETAILS B,C & D

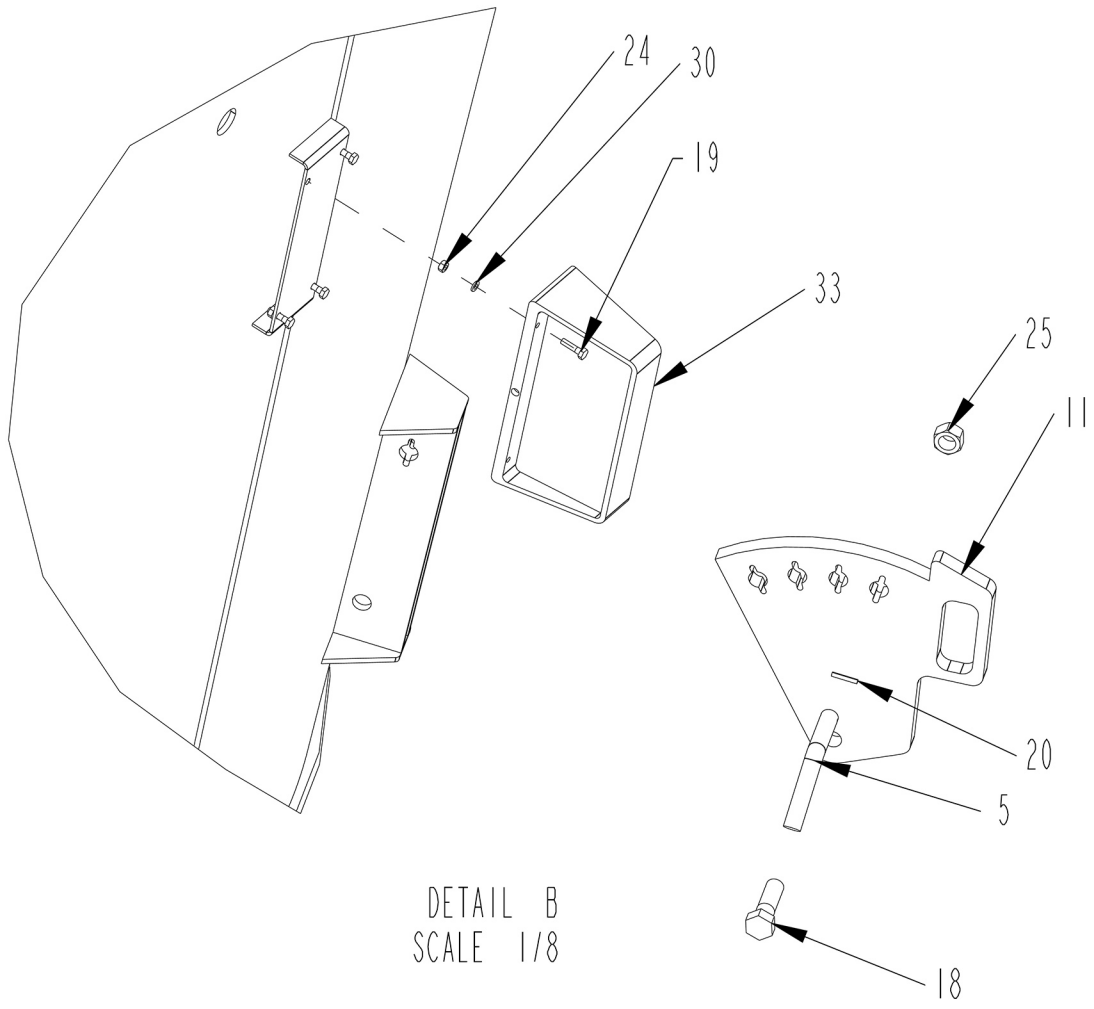

DETAIL B
SCALE 1/8

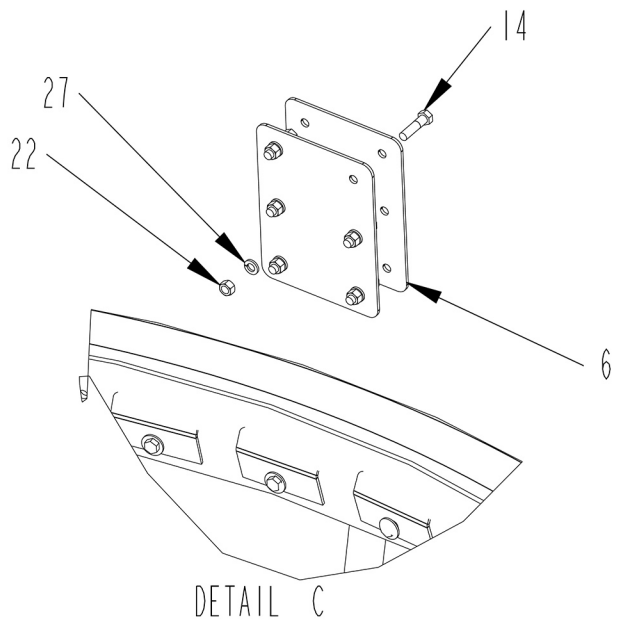

DETAIL C

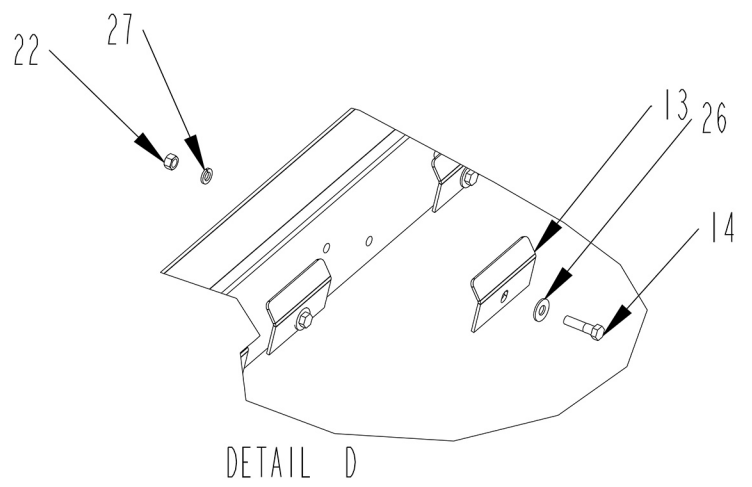

DETAIL D

TUB ASSEMBLY DETAIL E

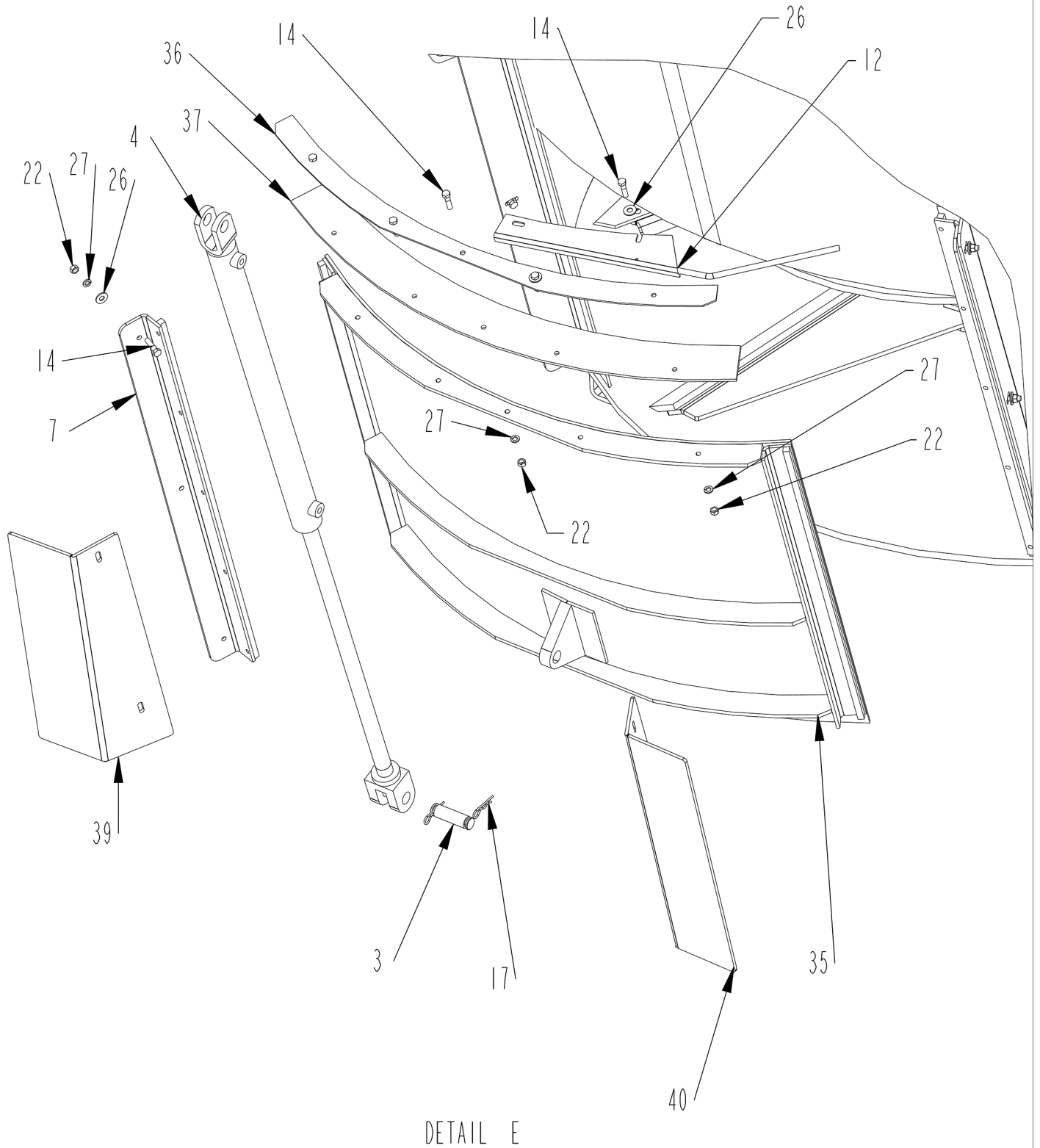



TUB ASSEMBLY PARTS LIST

ITEM	PART	QTY.	PART DESCRIPTION
1	3100214	2	GRBX\PLANETARY\DBL\1800
2	3600648	1	PTO\242-24190\35E\W\CLUTCH
3	4100030	2	PIN 1" X 3-1/2" HYD. CYL.
4	4100247	1	CYL\HYD\2"X30"\1-1/8_ROD
5	4704181	2	PIN\LOCK\3/4X2-1/2
6	4704340	2	PL\CLMP\EXT\TUB
7	4704359	2	BRKT\DOOR\ASSY
8	4704372	4	PL\COVER\WNDW\CMF
9	4704373	4	PL\SPACER\COVER\WNDW\CMF
10	4704506	2	TANK\HYD\ASSY\CMF
11	4704567	2	KNIFE\VERT
12	4705153	1	INDICATOR\HEIGHT\DOOR
13	4705376	84	CLAMP\BELT\CMF300
14	4800034	101	BOLT\HEX\3/8X1-1/2
15	4800071	8	BOLT\HEX\5/16X1-1/4
16	4800081	20	BOLT\HEX\5/16X1-1/2
17	4800107	4	PIN\HAIR\1/8(#9)
18	4800115	2	BOLT\HEX\3/4X2-1/2
19	4800277	8	BOLT\HEX\1/4X1
20	4800456	2	PIN\RLLD\3/16X1-1/8
21	4800948	54	BOLT\HEX\M16XM60
22	4900002	113	NUT\HEX\3/8\NC
23	4900003	28	NUT\HEX\5/16\NC
24	4900009	8	NUT\HEX\1/4\NC
25	4900139	2	NUT\TPLCK\3/4\GR8\NC
26	5000001	92	WASH\FLAT\3/8
27	5000019	113	WASH\LOCK\3/8
28	5000022	28	WASH\LOCK\5/16
29	5000023	8	WASH\FLAT\5/16
30	5000024	8	WASH\LOCK\1/4
31	5000114	54	WASH\FLAT\5/8\EXTRTHK\GR8
32	5701058	1	TAILLIGHT\RED;RIGHT\LED\ASSY\4PIN
33	5701059	1	TAILLIGHT\RED;LEFT\LED\ASSY\4PIN
34	5900006	1	TUB\WELD\CMF710
35	5900009	1	DOOR\TUB
36	5900011	1	SH\DBLR\SEAL\DOOR
37	5900012	1	BELT\DOOR\CMF710
38	5900013	2	AUGER\ASSY
39	5900016	1	EXT\DOOR\RH
40	5900017	1	EXT\DOOR\LH
41	5900018	1	BELT\12"\EXT\CMF710
42	7501138	2	WEATHERSTRIP\2PC\1/4X3/8X69
43	7501139	2	WNDW\POLYCARB\8X30X3/8
44	7501336	5	CLMP\HOSE\CUSH\3/8
45	7501525	4	CLAMP\HOSE\1/2\2

5900005

TUB\ASSY\CMF710

NOT SHOWN

5900112

KIT\LINER\TUB\CMF710

MAINFRAME ASSEMBLY

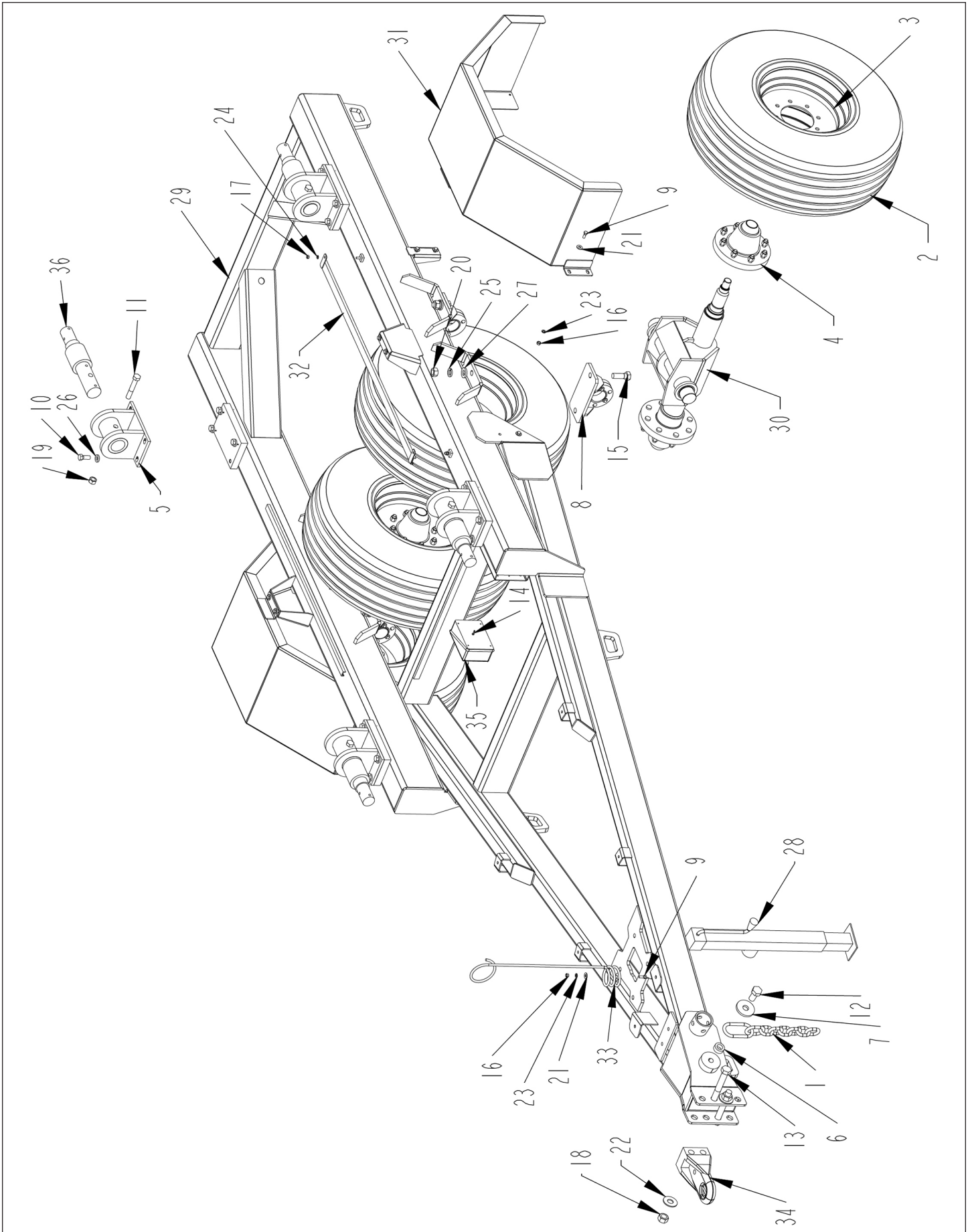

MAINFRAME ASSEMBLY

ITEM	PART	QTY.	PART DESCRIPTION
1	1100255	1	CHAIN\SAFETY\AG\1/2"\40K_CAP
2	2600870	4	TIRE\14L-16.1X12PLY
3	2600871	4	WHL\8-BOLT\16.1xW11C\+1-1/8OFFSET\5K
	2600869		WHL\ASSY\14LX16.1-12PLY (Includes #2 & #3)
4	2900140	4	HUB\ASSY\H817\8BOLT\8"B.C.\6"PILOT (SEE HUB ASSEMBLY)
5	4703989	4	MNT\LOADCELL\FRAME
6	4704337	1	BUSHING\MNT\CHAIN\SAFETY
7	4704338	1	WASHER\CHAIN\SAFETY
8	4704878	4	CUP\BRG\AXLE\CMF\ASSY
9	4800003	13	BOLT\HEX\3/8X1
10	4800106	16	BOLT\HEX\5/8X1-1/2
11	4800139	4	BOLT\HEX\3/4X4-1/2
12	4800547	1	BOLT\HEX\1X2\NC
13	4800919	2	BOLT\HEX\1X6-1/2\GR5\NC
14	4801231	4	SCR\HEX\#8-18X3/4"\SELF-DRILLING
15	4801234	8	BOLT\HEX\7/8X2-1/2\GR8\NC
16	4900002	13	NUT\HEX\3/8\NC
17	4900003	2	NUT\HEX\5/16\NC
18	4900015	2	NUT\NYLCK\1\NC
19	4900139	4	NUT\TPLCK\3/4\GR8\NC
20	4900192	8	NUT\HEX\7/8\GR8\NC
21	5000001	13	WASH\FLAT\3/8
22	5000014	2	WASH\FLAT\1
23	5000019	13	WASH\LOCK\3/8
24	5000022	2	WASH\LOCK\5/16
25	5000106	8	WASH\LOCK\7/8
26	5000114	16	WASH\FLAT\5/8\EXTRTHK\GR8
27	5000120	8	WASH\FLAT\7/8\EXTRTHK\GR8
28	5800627	1	JACK\7000LB\SWIVEL-STYLE
29	5900002	1	FRAME\WELD\CMF710
30	5900004	2	AXLE\WELD\CMF710
31	5900020	2	FENDER\CMF710
32	5900087	1	CHNNL\FRM\WIRE
33	7500170	1	HOSE MINDER
34	7500641	1	HITCH\BASE\#3\PP\1"PIN
35	7500978	1	2620 LOADCELL JUCTION BOX, 2000
36	7501326	4	DIGI-STAR_2.5_CELL

5900001

FRAME\ASSY\CMF710

NOT SHOWN

5700226	1	ENCL\BATT\PLSTC\GRP27
5700227	1	BATT\12VDC\GRP24
5700275	2	TERM\BATT\UNIV\MARINE\
7501326	1	LOADCELL\2.5"DBND\21'CABLE

DRIVE LINE OPTION - STANDARD - 1-3/4 CV

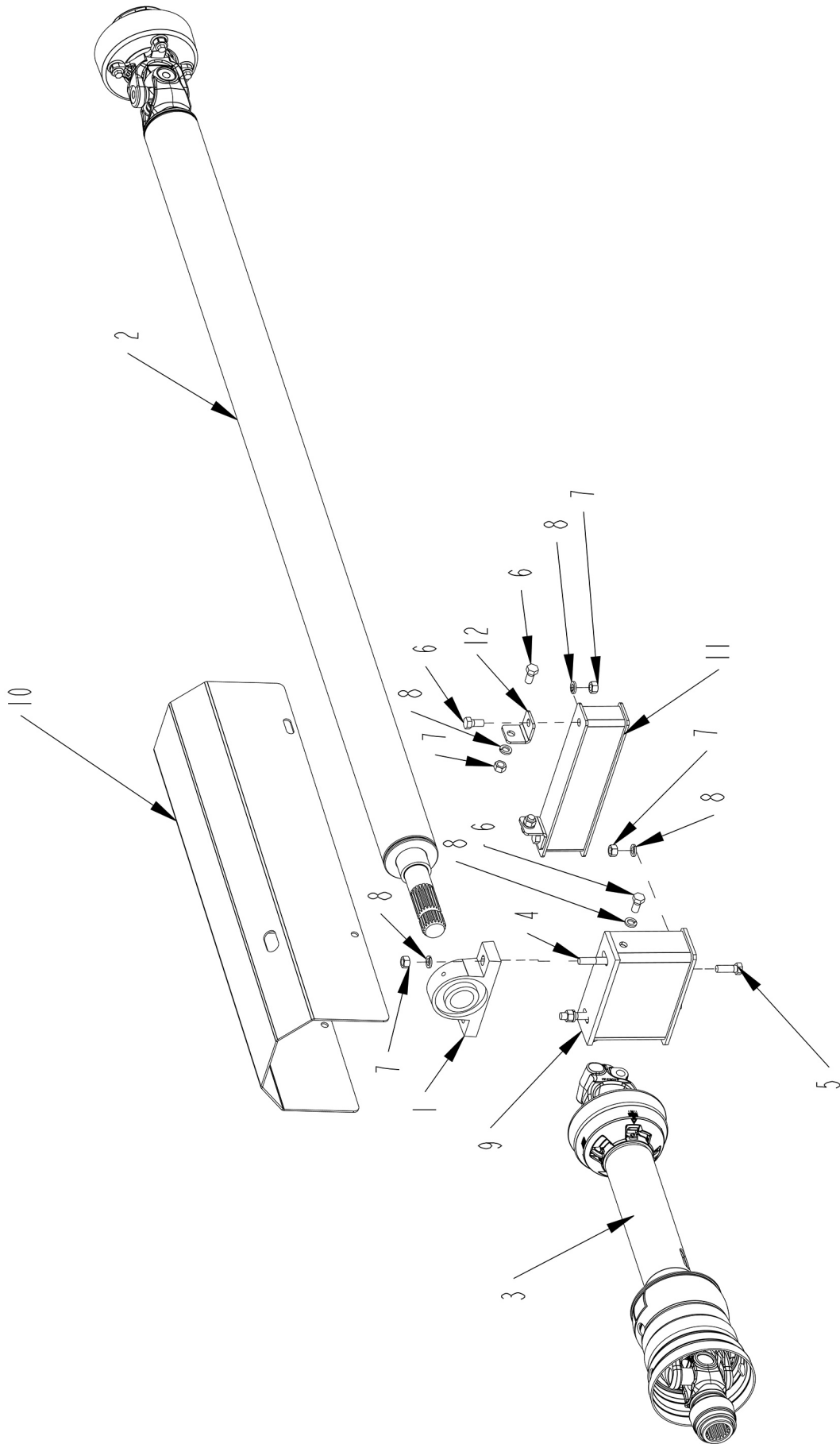

DRIVE LINE OPTION - STANDARD - 1-3/4 CV

ITEM	PART	QTY.	PART DESCRIPTION
1	2000514	1	BRG\PB\1-3/4\2BOLT\MALLEABLE
2	3600596	1	PTO\44E\18KAUTO\NO2SPD
3	3600787	1	PTO\255-25002\44E\1-3/4CV\WWCV
4	4800070	2	BOLT\HEX\1/2X2-1/2
5	4800082	2	BOLT\HEX\1/2X1-1/2
6	4800085	6	BOLT\HEX\1/2X1
7	4900001	8	NUT\HEX\1/2\NC
8	5000006	10	WASH\LOCK\1/2
9	5900019	1	MNT\BRG\PB\FRM
10	5900041	1	SHIELD\DRVLN\STNDRD\CMF710
11	5900042	1	BRKT\SHIELD\DRVLN\STNDRD
12	5900043	2	ANGLE\BRKT\SHLD
	5900045		DRVLN\STND\1-3/4CV\CMF710

DRIVE LINE OPTION - STANDARD - 1-3/8 CV

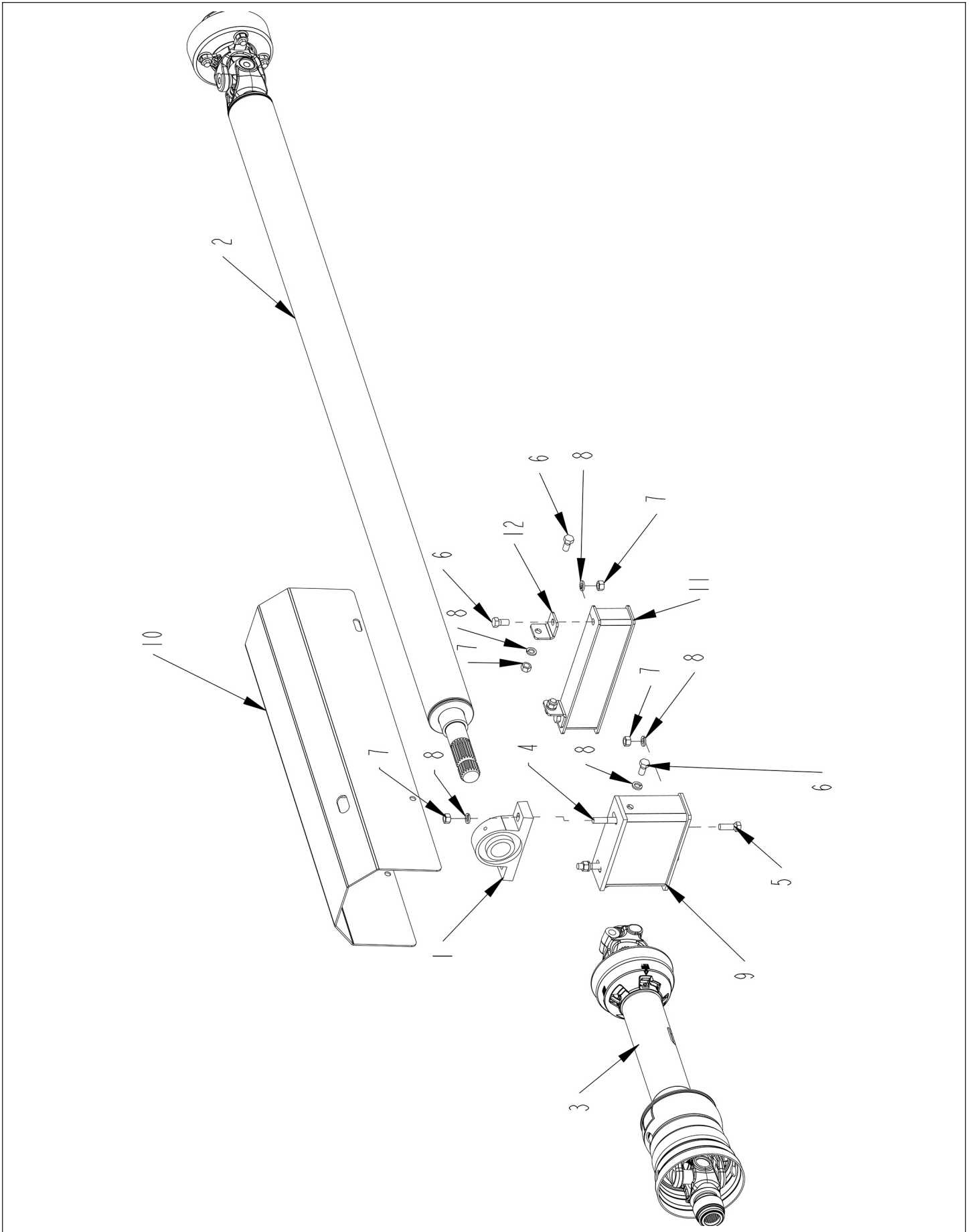

DRIVE LINE OPTION - STANDARD - 1-3/8 CV

ITEM	PART	QTY.	PART DESCRIPTION
1	2000514	1	BRG\PB\1-3/4\2BOLT\MALLEABLE
2	3600596	1	PTO\44E\18KAUTO\NO2SPD
3	3600791	1	PTO\255-25000\44E\1-3/8CV-21WWCV
4	4800070	2	BOLT\HEX\1/2X2-1/2
5	4800082	2	BOLT\HEX\1/2X1-1/2
6	4800085	6	BOLT\HEX\1/2X1
7	4900001	8	NUT\HEX\1/2\NC
8	5000006	10	WASH\LOCK\1/2
9	5900019	1	MNT\BRG\PB\FRM
10	5900041	1	SHIELD\DRVLN\STNDRD\CMF710
11	5900042	1	BRKT\SHIELD\DRVLN\STNDRD
12	5900043	2	ANGLE\BRKT\SHLD
	5900044		DRVLN\STND\1-3/8CV\CMF710

DRIVE LINE OPTION - 2 SPEED GEARBOX - 1-3/4 CV

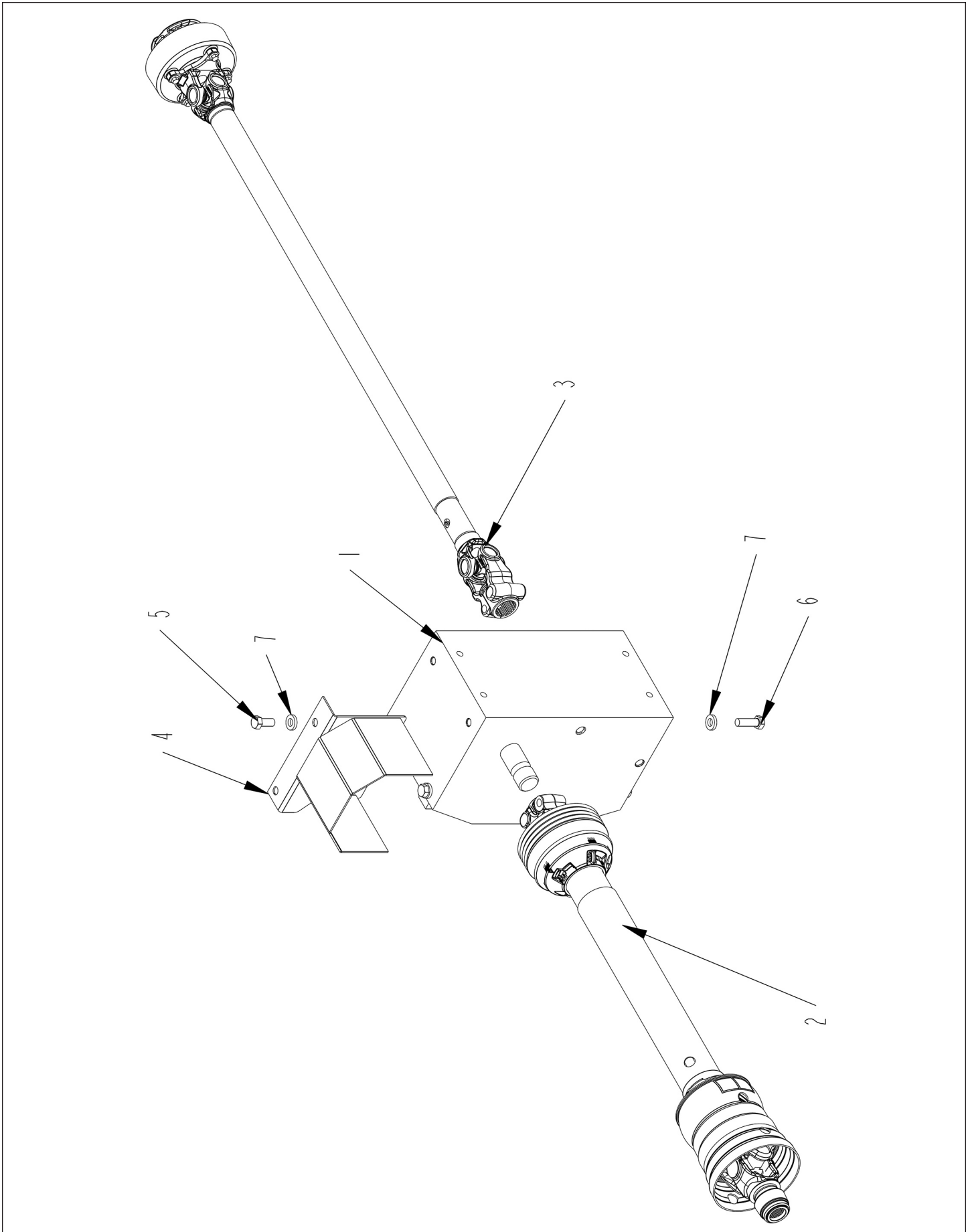

DRIVE LINE OPTION - 2 SPEED GEARBOX - 1-3/4 CV

ITEM	PART	QTY.	PART DESCRIPTION
1	3100225	1	GRBX\2SPD\1.84:1\B&P6078
2	3600783	1	PTO\255-25003\44E\1-3/4 WWCV
3	3600819	1	PTO\44E\18KCLTCH
4	4704546	1	SHLD\DRVLN\2SPD\GRBX\FRNT
5	4800565	2	BOLT\HEX\M16XM35
6	4800944	4	BOLT\HEX\M16XM50
7	5000114	6	WASH\FLAT\5/8\EXTRTHK\GR8
	5900047		DRVLN\2SPD\1-3/4CV\CMF710

DRIVE LINE OPTION - 2 SPEED GEARBOX - 1-3/8 CV

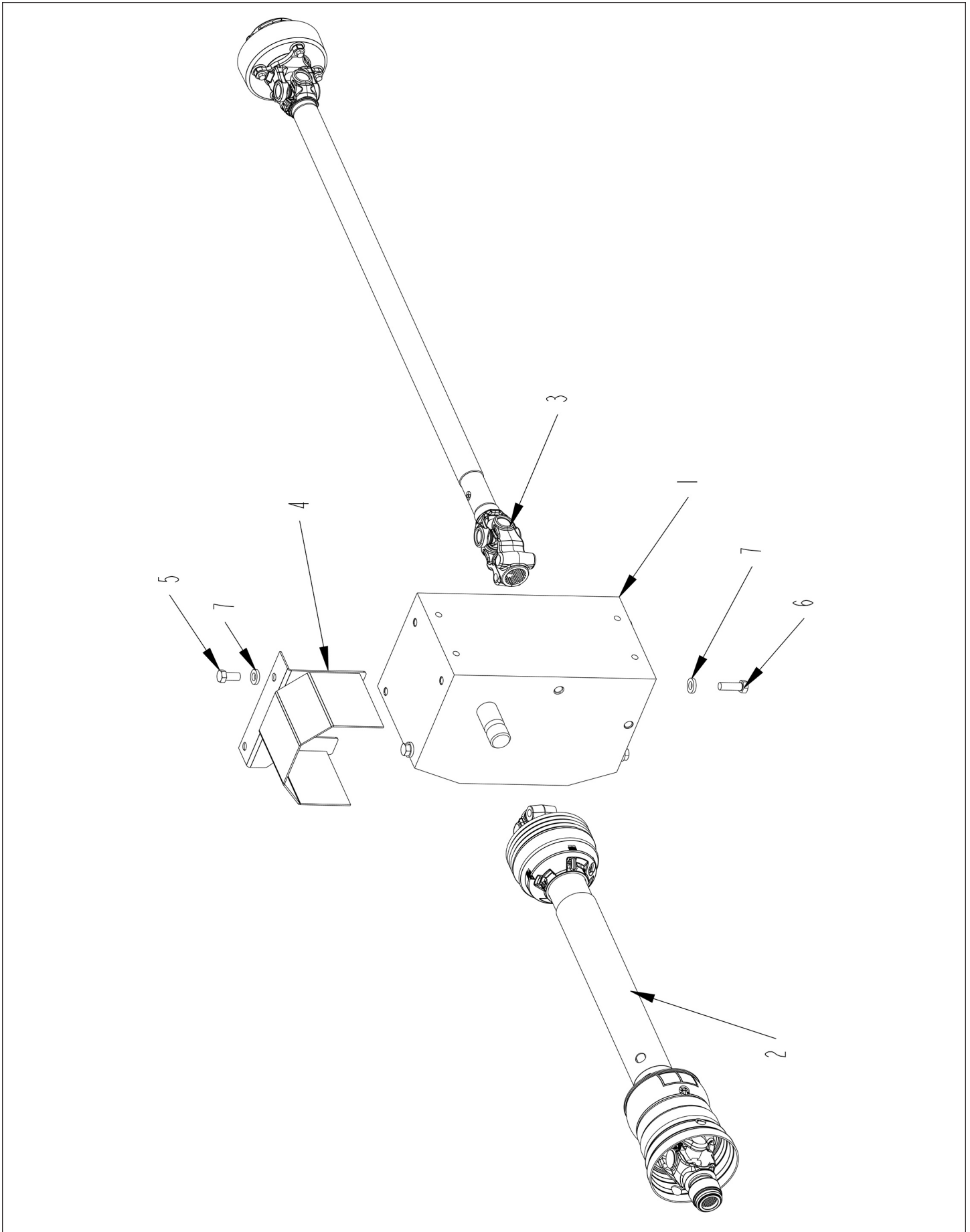

DRIVE LINE OPTION - 2 SPEED GEARBOX - 1-3/8 CV

ITEM	PART	QTY.	PART DESCRIPTION
1	3100225	1	GRBX\2SPD\1.84:1\B&P6078
2	3600785	1	PTO\255-25005\44E\1-3/8 WWCV
3	3600819	1	PTO\44E\18KCLTCH
4	4704546	1	SHLD\DRVLN\2SPD\GRBX\FRNT
5	4800565	2	BOLT\HEX\M16XM35
6	4800944	4	BOLT\HEX\M16XM50
7	5000114	6	WASH\FLAT\5/8\EXTRTHK\GR8
	5900046		DRVLN\2SPD\1-3/8CV\CMF710

AUGER ASSEMBLY (FOR S.N. UP TO VM17002571)

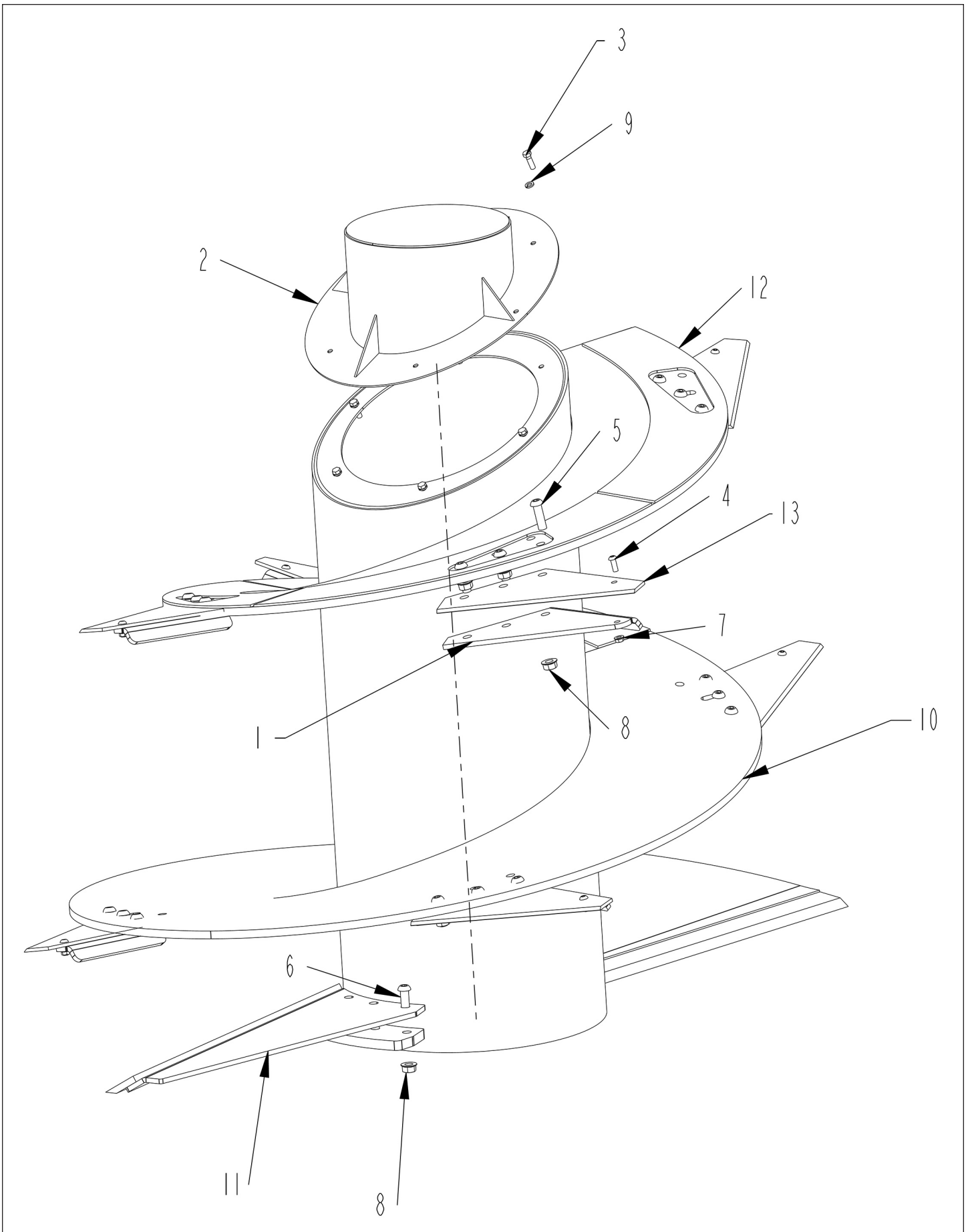

AUGER ASSEMBLY (FOR S.N. UP TO VM17002571)

ITEM	PART	QTY.	PART DESCRIPTION
1	4704365	7	PL\BACK\BLADE
2	4704884	1	COVER\AUGER
3	4800098	6	BOLT\HEX\3/8X1-1/4\NC
4	4800244	7	SCR\BUT\ALN\3/8X1\NC
5	4800659	21	SCR\BUT\ALN\5/8X2\NC
6	4801290	3	SCR\BUT\ALN\5/8X1-3/4\NC
7	4900076	7	NUT\FLG\SERR\3/8\NC
8	4900110	24	NUT\FLG\SERR\5/8\NC
9	5000019	6	WASH\LOCK\3/8
10	5900014	1	AUGER\WELD\CMF710
11	5900015	1	KICKER\AUGER\CMF710
12	5900061	4	AUGER\CMF700/830\LINER\TOP
13	7501161	7	BLADE\CMF\STANDARD
	5900013		AUGER\ASSY\CMF710

AUGER ASSEMBLY (FOR S.N. VM17002671 AND UP)

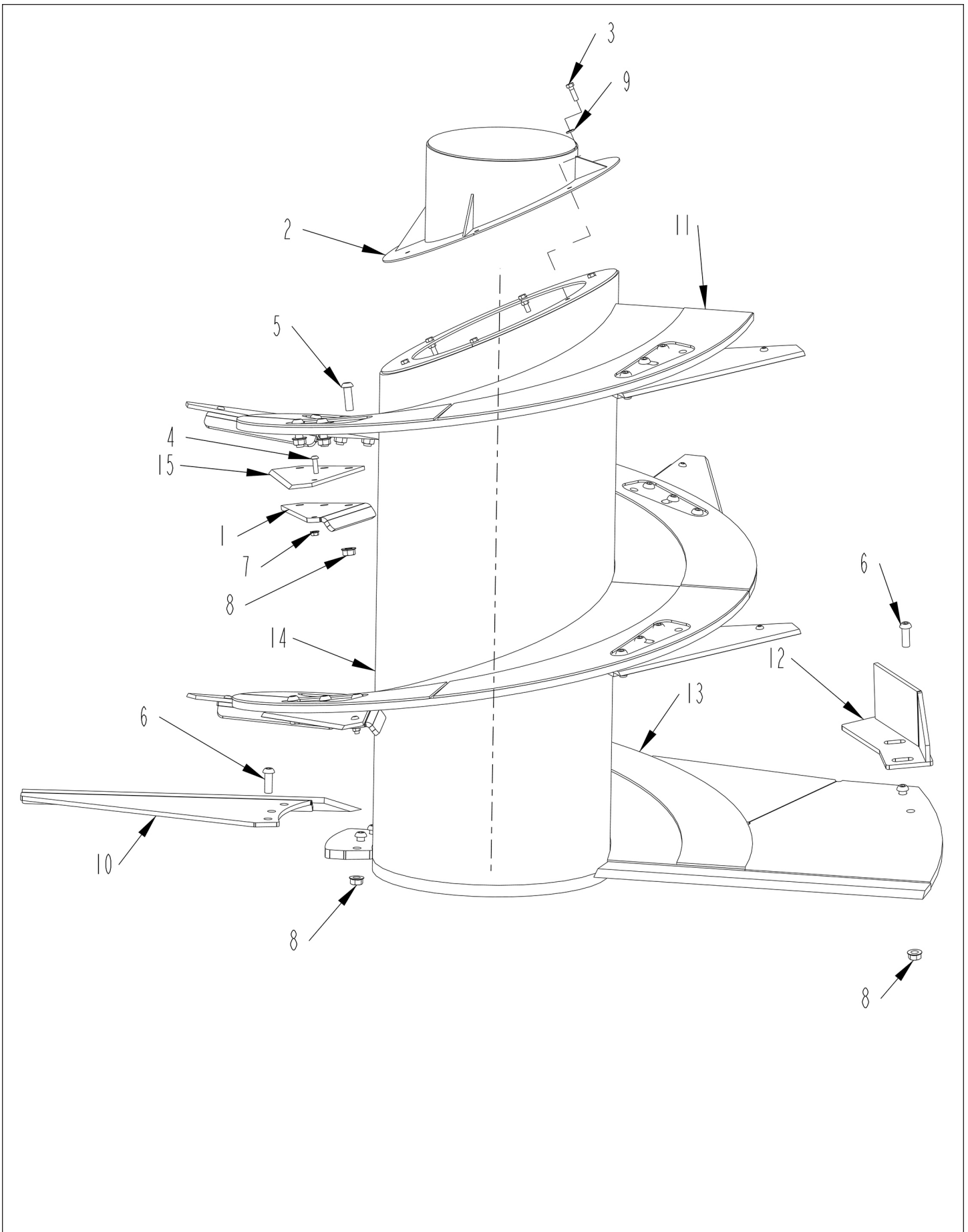

LEFT HAND DISCHARGE CONVEYOR ASSEMBLY

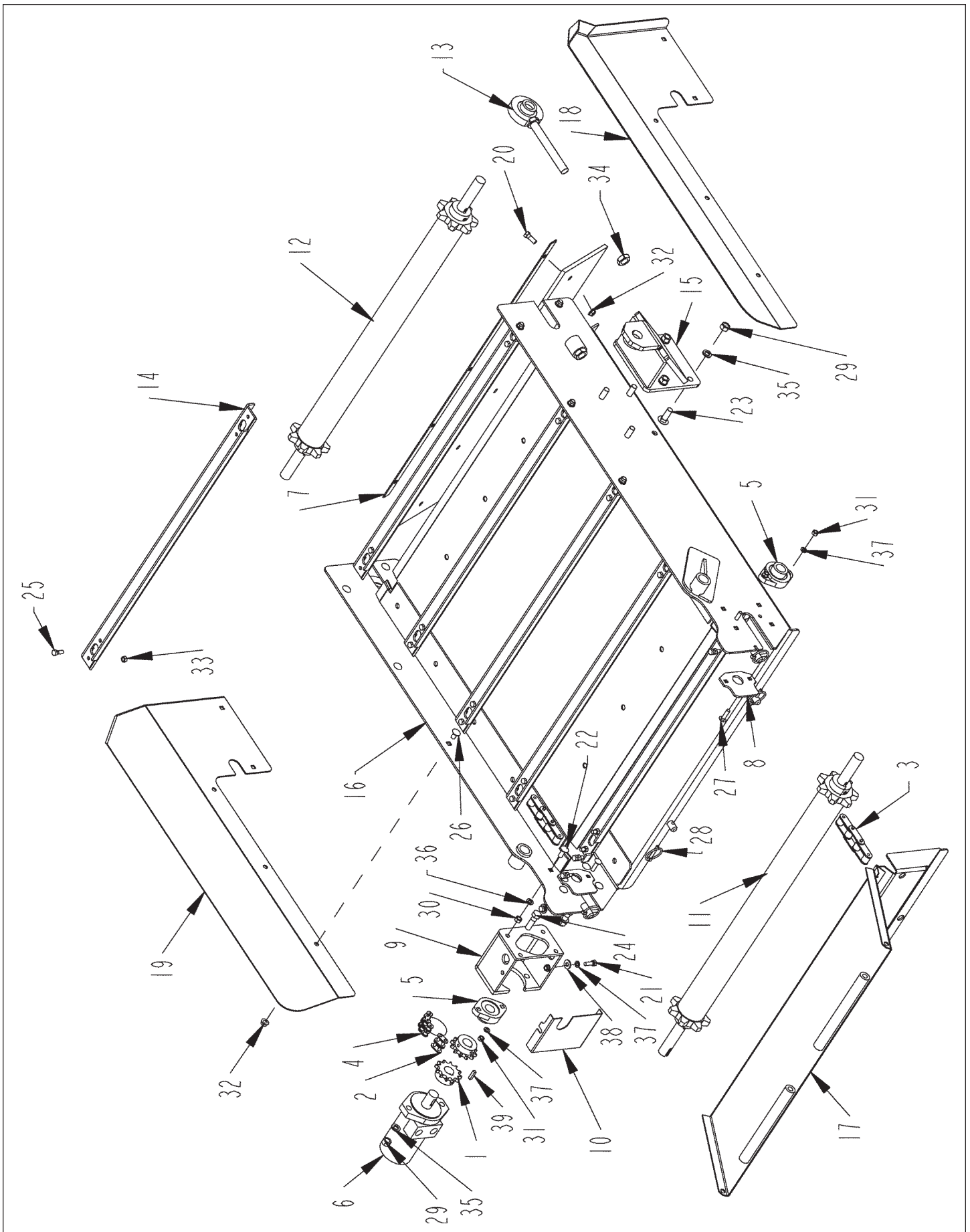

LEFT HAND DISCHARGE CONVEYOR ASSEMBLY

ITEM	PART	QTY.	PART DESCRIPTION
1	1000055	2	SPKT\50\B\12\1\1/4KW
2	1100099	1	CHAIN\50DBL\CL
3	1100150	2	CHAIN\620CA\53\W\ATTCH
4	1100271	1	CHAIN\50DBL\11
5	2000310	2	BRG\FLG\CAST\1\2BOLT
6	3900025	1	MOTOR\HYD\17.9\H
7	4704325	1	FLAT\WIPER\CNVYR
8	4704327	2	GUARD\CNVYR
9	4704558	1	MNT\MTR\CNVYR\CMF
10	4704559	1	SHLD\CPLR\CNVYR
11	4704576	1	SHAFT\ASSY\CNVYR\CMF
12	4704581	1	IDLER\ASSY\CNVYR\CMF
13	4704583	2	MNT\BRG\CNVYR\CMF
14	4704584	9	SLAT\CHAIN\EXT\CNVYR
15	4704971	1	BRKT\CYL\EXT\CNVYR\CMF
16	4704992	1	CNVYR\EXT\WELD\CMF
17	4704993	1	PAN\TRANS\CNVYR
18	4704994	1	EXT\SIDE\CNVYR\RH
19	4704995	1	EXT\SIDE\CNVYR\LH
20	4800003	5	BOLT\HEX\3/8X1
21	4800013	2	BOLT\HEX\5/16X1
22	4800053	4	BOLT\CRG\3/8X1\NC
23	4800061	4	BOLT\CRG\1/2X1-1/2\NC
24	4800178	2	BOLT\HEX\1/2X1-3/4
25	4800393	36	BOLT\HEX\5/16X7/8\GR8
26	4800394	8	BOLT\CRG\3/8X3/4\NC
27	4800474	4	BOLT\CRG\5/16X1-1/4\NC
28	4801236	4	PIN\LYNCH\1/4X1-9/16\ZN_PLT
29	4900001	6	NUT\HEX\1/2\NC
30	4900002	4	NUT\HEX\3/8\NC
31	4900003	4	NUT\HEX\5/16\NC
32	4900076	13	NUT\FLG\SERR\3/8\NC
33	4900099	36	NUT\TPLCK\5/16\GR8\NC
34	4900104	6	NUT\JAM\3/4\NC
35	5000006	6	WASH\LOCK\1/2
36	5000019	4	WASH\LOCK\3/8
37	5000022	6	WASH\LOCK\5/16
38	5000023	2	WASH\FLAT\5/16
39	6200010	1	KEY\SQ\1/4X1

4704976

SIDE\LH\CNVYR\ASSY

COMPLETE LEFT HAND DISCHARGE CONVEYOR ASSEMBLY

ITEM	PART	QTY.	PART DESCRIPTION
1	4100030	2	PIN 1" X 3-1/2" HYD. CYL.
2	4704329	1	ROD\TRANS\CNVYR
3	4704330	2	PIN\SIDE\CNVYR
4	4704593	1	GATE\END\CNVYR\ASSY
5	4704976	1	SIDE\LH\CNVYR\ASSY
6	4800107	4	PIN\HAIR\1/8(#9)
7	4800160	2	BOLT\HEX\7/16X1-1/4
8	4800201	2	BOLT\CRG\1/2X1-3/4\NC\GR5
9	4800307	2	SCR\SET\SQ\3/8X1\NC
10	4800531	2	PIN\COT\3/16X3/4
11	4900014	2	NUT\TPLCK\1/2\NC
12	4900025	2	NUT\HEX\7/16\NC
13	4900026	2	NUT\JAM\3/8\NC
14	5000004	2	WASH\FLAT\1/2
15	5000014	2	WASH\FLAT\1
16	5000015	2	WASH\LOCK\7/16
17	5000016	2	WASH\FLAT\7/16
18	5000123	2	WASH\FLAT\7/16\EXTRTHK\GR8
19	4100284	1	CYL\HYD\2X16\1-1/4RD\WELDE
20	4704972	1	CNVYR\ASSY\MAIN\CMF\LH

4704978

CMF\CNVYR\W\LH_EXT

RIGHT HAND DISCHARGE CONVEYOR ASSEMBLY

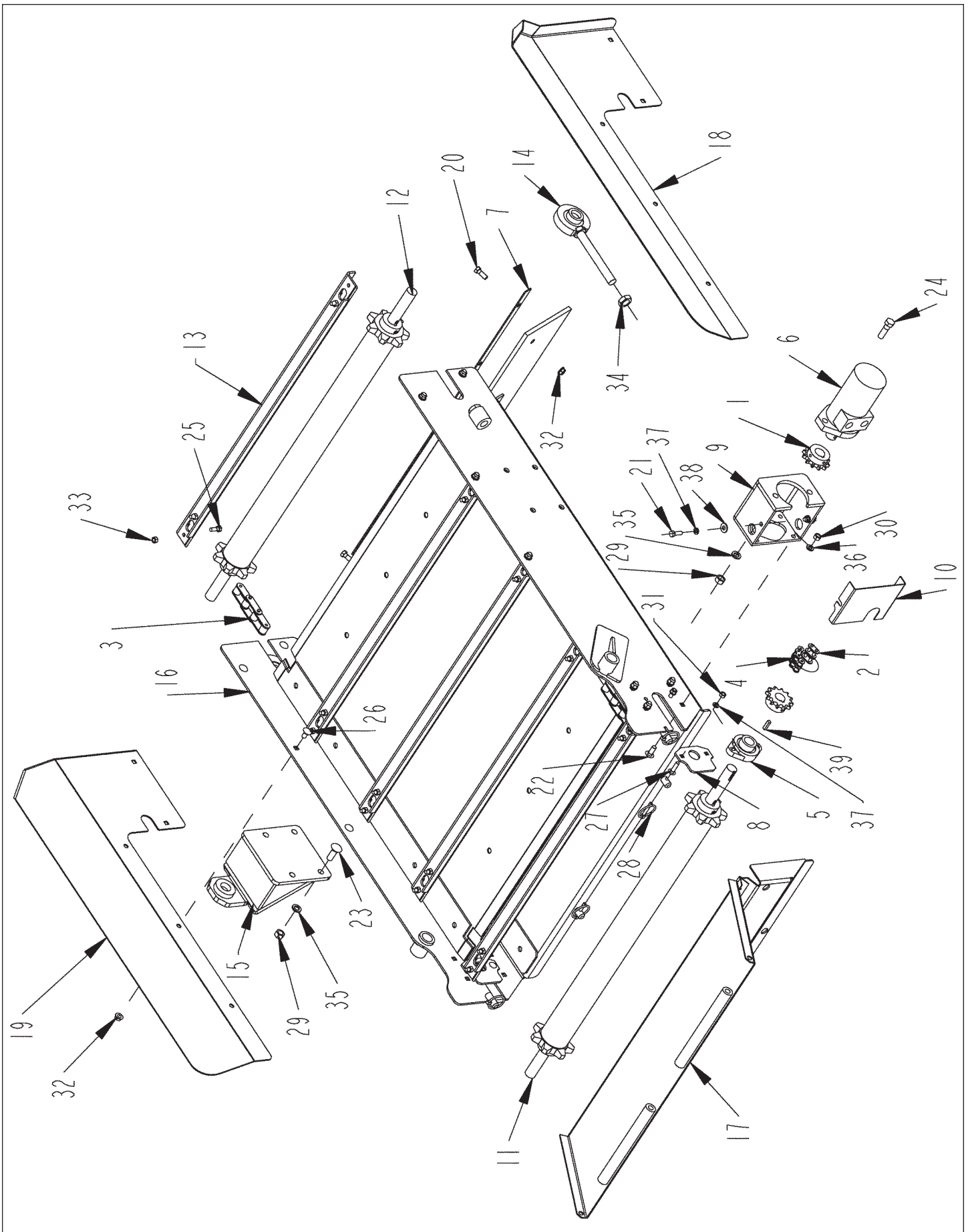

RIGHT HAND DISCHARGE CONVEYOR ASSEMBLY

ITEM	PART	QTY.	PART DESCRIPTION
1	1000055	2	SPKT\50\B\12\1\1/4KW
2	1100099	1	CHAIN\50DBL\CL
3	1100150	2	CHAIN\620CA\53\W\ATTCH
4	1100271	1	CHAIN\50DBL\11
5	2000310	2	BRG\FLG\CAST\1\2BOLT
6	3900025	1	MOTOR\HYD\17.9\H
7	4704325	1	FLAT\WIPER\CNVYR
8	4704327	2	GUARD\CNVYR
9	4704558	1	MNT\MTR\CNVYR\CMF
10	4704559	1	SHLD\CPLR\CNVYR
11	4704576	1	SHAFT\ASSY\CNVYR\CMF
12	4704581	1	IDLER\ASSY\CNVYR\CMF
13	4704584	9	SLAT\CHAIN\EXT\CNVYR
14	4704585	2	BRG\ASSY\CNVYR\CMF
15	4704971	1	BRKT\CYL\EXT\CNVYR\CMF
16	4704992	1	CNVYR\EXT\WELD\CMF
17	4704993	1	PAN\TRANS\CNVYR
18	4704994	1	EXT\SIDE\CNVYR\RH
19	4704995	1	EXT\SIDE\CNVYR\LH
20	4800003	5	BOLT\HEX\3/8X1
21	4800013	2	BOLT\HEX\5/16X1
22	4800053	4	BOLT\CRG\3/8X1\NC
23	4800061	4	BOLT\CRG\1/2X1-1/2\NC
24	4800178	2	BOLT\HEX\1/2X1-3/4
25	4800393	36	BOLT\HEX\5/16X7/8\GR8
26	4800394	8	BOLT\CRG\3/8X3/4\NC
27	4800474	4	BOLT\CRG\5/16X1-1/4\NC
28	4801236	4	PIN\LYNCH\1/4X1-9/16\ZN_PLT
29	4900001	6	NUT\HEX\1/2\NC
30	4900002	4	NUT\HEX\3/8\NC
31	4900003	4	NUT\HEX\5/16\NC
32	4900076	13	NUT\FLG\SERR\3/8\NC
33	4900099	36	NUT\TPLCK\5/16\GR8\NC
34	4900104	6	NUT\JAM\3/4\NC
35	5000006	6	WASH\LOCK\1/2
36	5000019	4	WASH\LOCK\3/8
37	5000022	6	WASH\LOCK\5/16
38	5000023	2	WASH\FLAT\5/16
39	6200010	1	KEY\SQ\1/4X1
	4704975		SIDE\RH\CNVYR\ASSY

COMPLETE RIGHT HAND DISCHARGE CONVEYOR ASSEMBLY

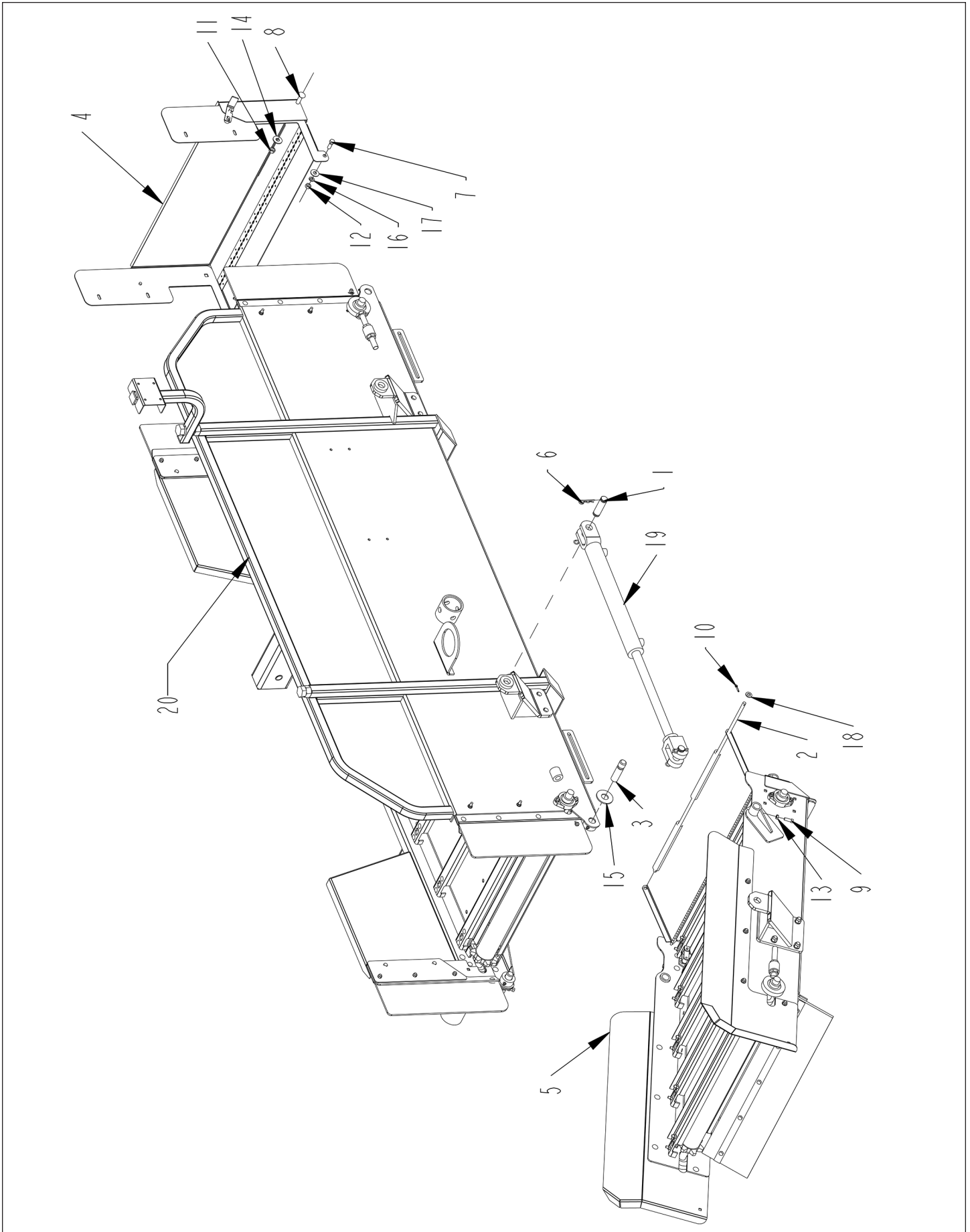

COMPLETE RIGHT HAND DISCHARGE CONVEYOR ASSEMBLY

ITEM	PART	QTY.	PART DESCRIPTION
1	4100030	2	PIN 1" X 3-1/2" HYD. CYL.
2	4704329	1	ROD\TRANS\CNVYR
3	4704330	2	PIN\SIDE\CNVYR
4	4704593	1	GATE\END\CNVYR\ASSY
5	4704975	1	SIDE\RH\CNVYR\ASSY
6	4800107	4	PIN\HAIR\1/8(#9)
7	4800160	2	BOLT\HEX\7/16X1-1/4
8	4800201	2	BOLT\CRG\1/2X1-3/4\NC\GR5
9	4800307	2	SCR\SET\SQ\3/8X1\NC
10	4800531	2	PIN\COT\3/16X3/4
11	4900014	2	NUT\TPLCK\1/2\NC
12	4900025	2	NUT\HEX\7/16\NC
13	4900026	2	NUT\JAM\3/8\NC
14	5000004	2	WASH\FLAT\1/2
15	5000014	2	WASH\FLAT\1
16	5000015	2	WASH\LOCK\7/16
17	5000016	2	WASH\FLAT\7/16
18	5000123	2	WASH\FLAT\7/16\EXTRTHK\GR8
19	4100284	1	CYL\HYD\2X16\1-1/4RD\WELDE
20	4704973	1	CNVYR\ASSY\MAIN\CMF\RH
	4704977		CNVYR\ASSY\W\RH_EXT

DUAL DISCHARGE CONVEYOR ASSEMBLY (OPTION)

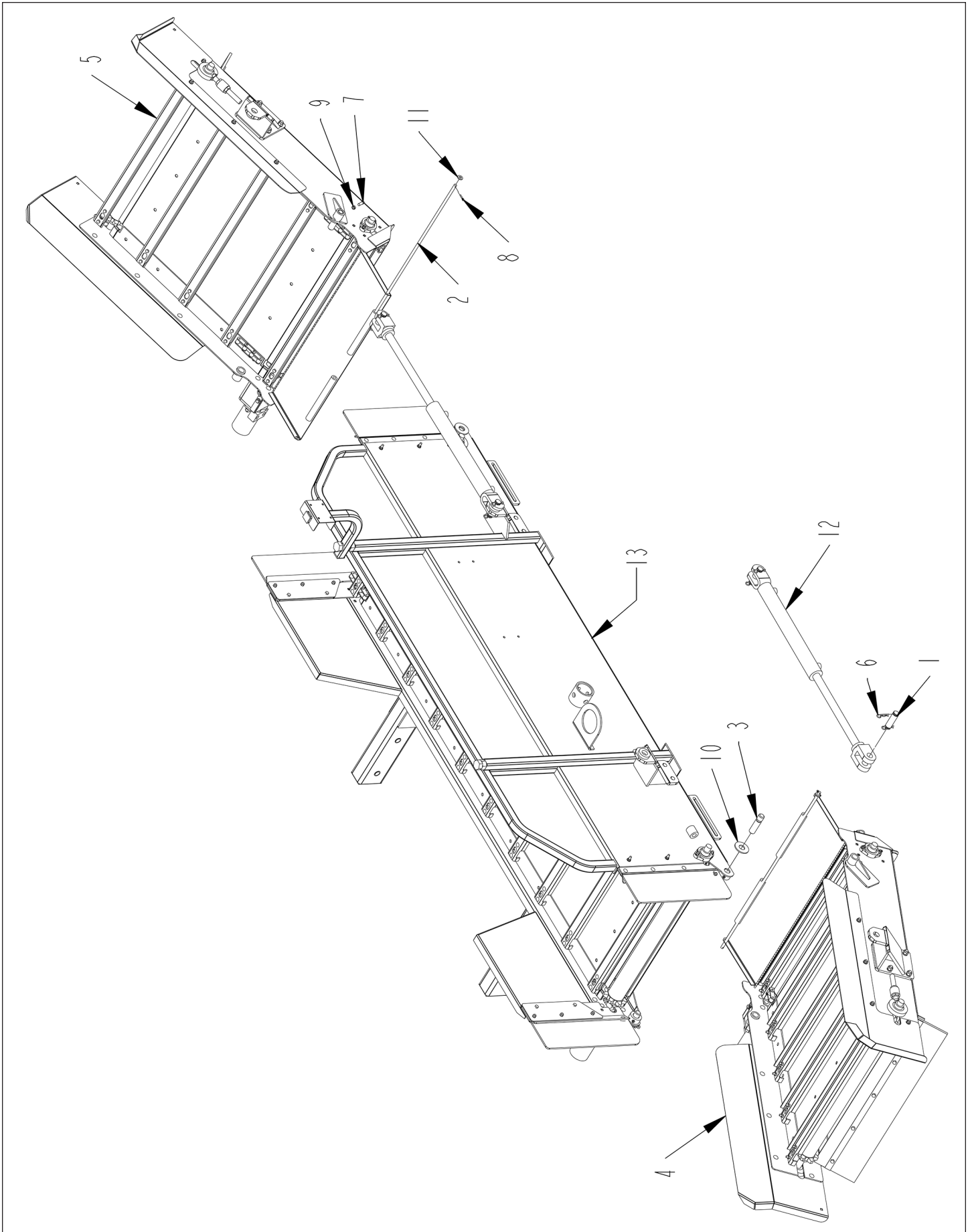

DUAL DISCHARGE CONVEYOR ASSEMBLY (OPTION)

ITEM	PART	QTY.	PART DESCRIPTION
1	4100030	4	PIN 1" X 3-1/2" HYD. CYL.
2	4704329	2	ROD\TRANS\CNVYR
3	4704330	4	PIN\SIDE\CNVYR
4	4704975	1	SIDE\RH\CNVYR\ASSY
5	4704976	1	SIDE\LH\CNVYR\ASSY
6	4800107	8	PIN\HAIR\1/8(#9)
7	4800307	4	SCR\SET\SQ\3/8X1\NC
8	4800531	4	PIN\COT\3/16X3/4
9	4900026	4	NUT\JAM\3/8\NC
10	5000014	4	WASH\FLAT\1
11	5000123	4	WASH\FLAT\7/16\EXTRTHK\GR8
12	4100284	2	CYL\HYD\2X16\1-1/4RD\WELDE
13	4704973	1	CNVYR\ASSY\MAIN\CMF\RH
	4704979		CMF\CNVYR\DUAL_EXT

**MAIN CONVEYOR ASSEMBLY-4704973 - SUB ASSEMBLY 1
(USE W/ DUAL & RH DISCHARGE)**

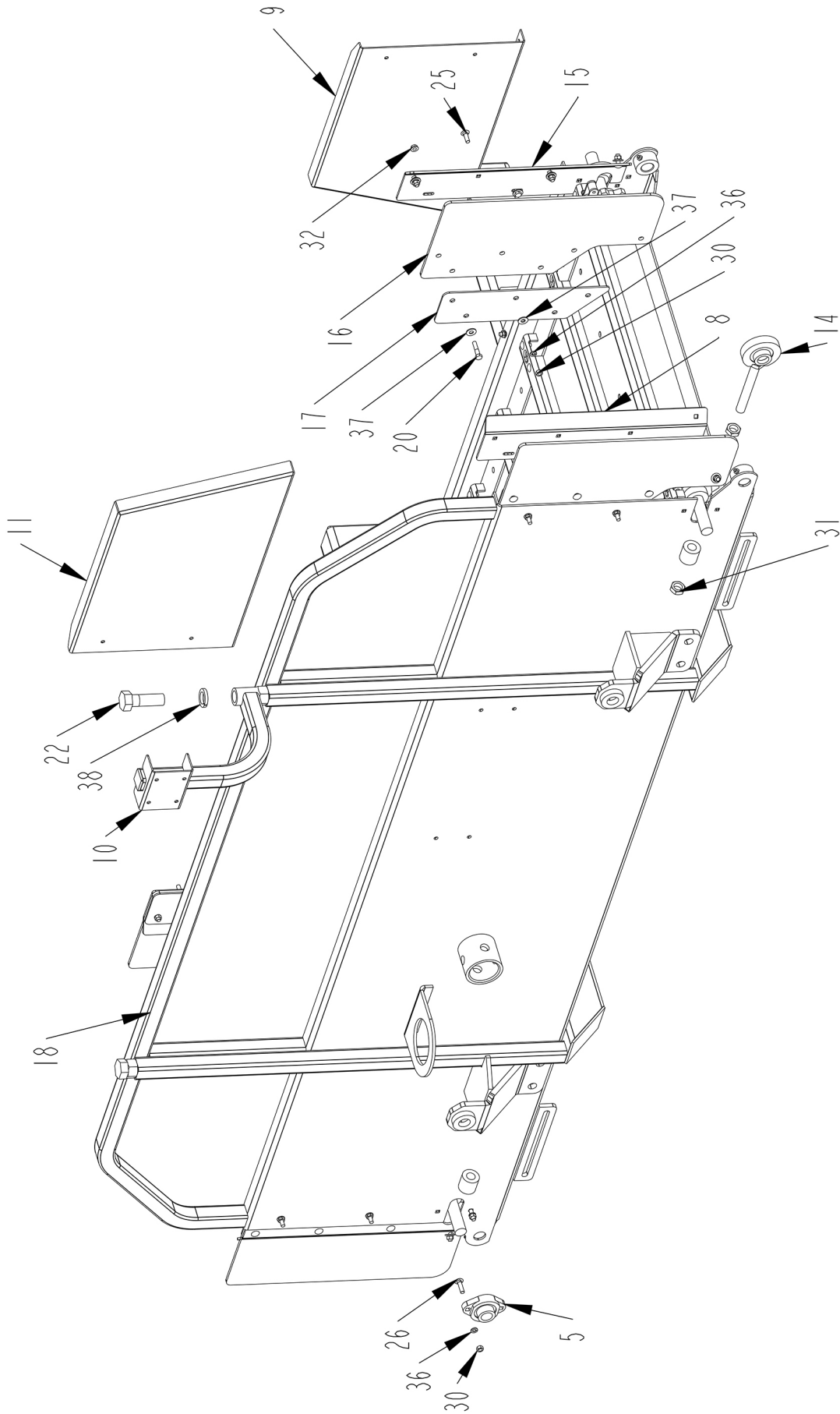

**MAIN CONVEYOR ASSEMBLY-4704973 - SUB ASSEMBLY 2
(USE W/ DUAL & RH DISCHARGE)**

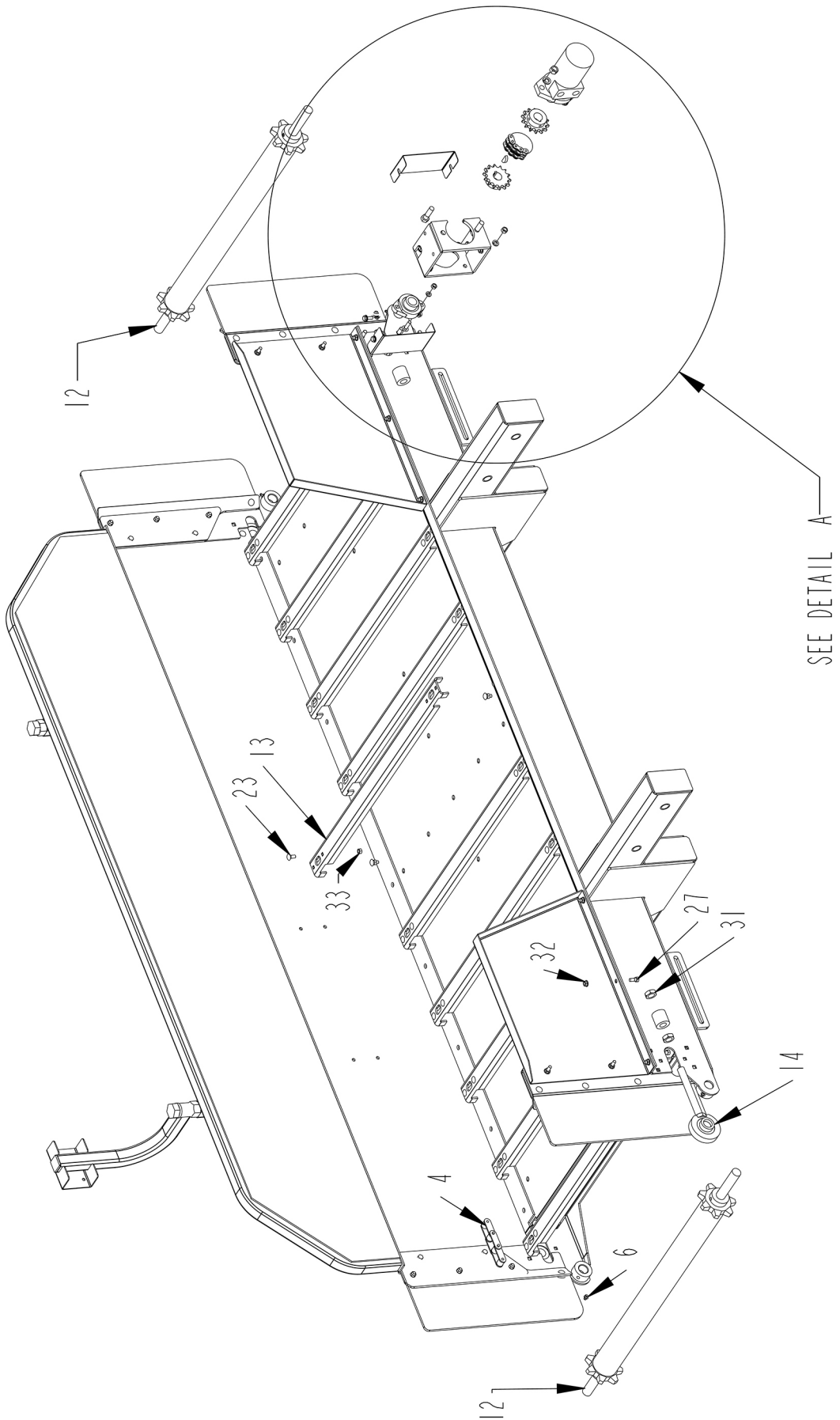

**MAIN CONVEYOR ASSEMBLY-4704973 - DETAIL A
(USE W/ DUAL & RH DISCHARGE)**

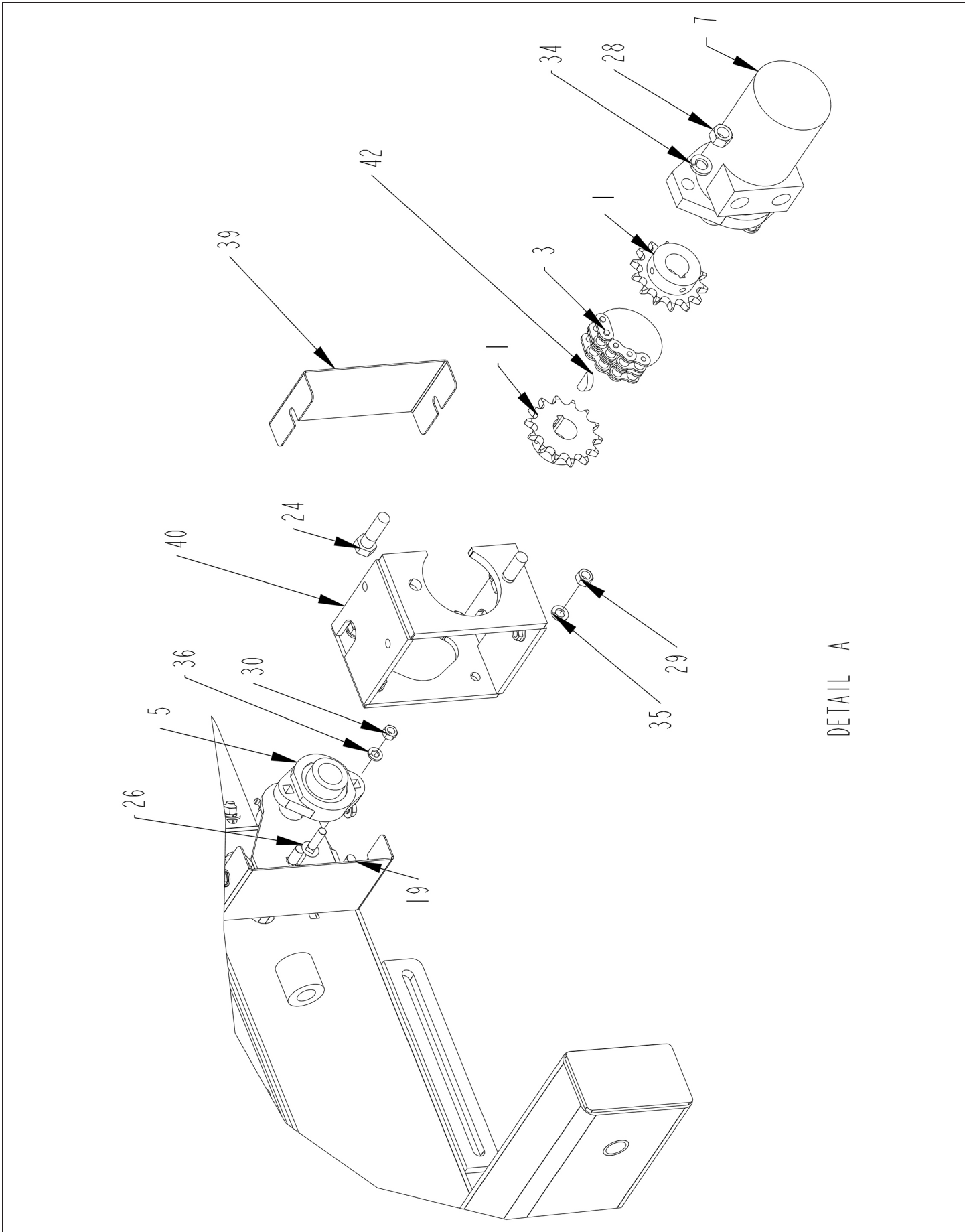

DETAIL A

**MAIN CONVEYOR ASSEMBLY-4704973 - PARTS LIST
(USE W/ DUAL & RH DISCHARGE)**

ITEM	PART	QTY.	PART DESCRIPTION
1	100029	2	SPKT\50\B\14\1\1/4KW
2	110026	1	CHAIN\50DBL\13
3	110099	1	CHAIN\50DBL\CL
4	1100256	2	CHAIN\620CA\120\W\ATTCH
5	2000310	2	BRG\FLG\CAST\1\2BOLT
6	3800043	4	FTG\LUB\1/8MPXZRK\SHORT
7	3900032	1	MOTOR\HYD\22.6\H
8	4704375	2	SH\DEFL\MAIN\CNVYR\RH
9	4704378	1	EXT\MAIN\CNVYR\LH
10	4704388	1	BRKT\IND\SCALE
11	4704519	1	EXT\MAIN\CNVYR\RH
12	4704576	2	SHAFT\ASSY\CNVYR\CMF
13	4704580	20	SLAT\CHAIN\CNVYR\CMF
14	4704585	2	BRG\ASSY\CNVYR\CMF
15	4704592	2	SH\DEFL\MAIN\CNVYR\LH
16	4704598	4	BELT\GUIDE\MATL\HINGE
17	4704859	4	DBLR\BELT\GUIDE\MATL\HINGE
18	4704970	1	CNVYR\MAIN\WELD\CMF
19	4800053	4	BOLT\CRG\3/8X1\NC
20	4800081	8	BOLT\HEX\5/16X1-1/2
21	4800113	4	SCR\FLNG\SERR\5/16X3/4\TP
22	4800140	2	BOLT\HEX\1X3\NC
23	4800153	80	BOLT\CRG\5/16X3/4\NC
24	4800178	2	BOLT\HEX\1/2X1-3/4
25	4800473	16	BOLT\CRG\5/16X1\NC
26	4800474	4	BOLT\CRG\5/16X1-1/4\NC
27	4800643	6	BOLT\HEX\5/16X3/4
28	4900001	2	NUT\HEX\1/2\NC
29	4900002	4	NUT\HEX\3/8\NC
30	4900003	20	NUT\HEX\5/16\NC
31	4900104	6	NUT\JAM\3/4\NC
32	4900108	18	NUT\FLG\SERR\5/16\NC
33	4900142	80	NUT\TPLCK\5/16\NC
34	5000006	2	WASH\LOCK\1/2
35	5000019	4	WASH\LOCK\3/8
36	5000022	20	WASH\LOCK\5/16
37	5000023	24	WASH\FLAT\5/16
38	5000053	1	WASH\LOCK\1
39	5900071	2	SHLD\CPLR\CNVYR
40	5900072	1	MNT\MTR\CNVYR\EXT\CMF
41	5900073	2	SHAFT\WELD\CNVYR\CMF
42	6200011	1	KEY\WDF\1/4X1
	4704973		CNVYR\ASSY\MAIN\CMF\RH

**MAIN CONVEYOR ASSEMBLY-4704972 - SUB ASSEMBLY 1
(USE W/LH DISCHARGE)**

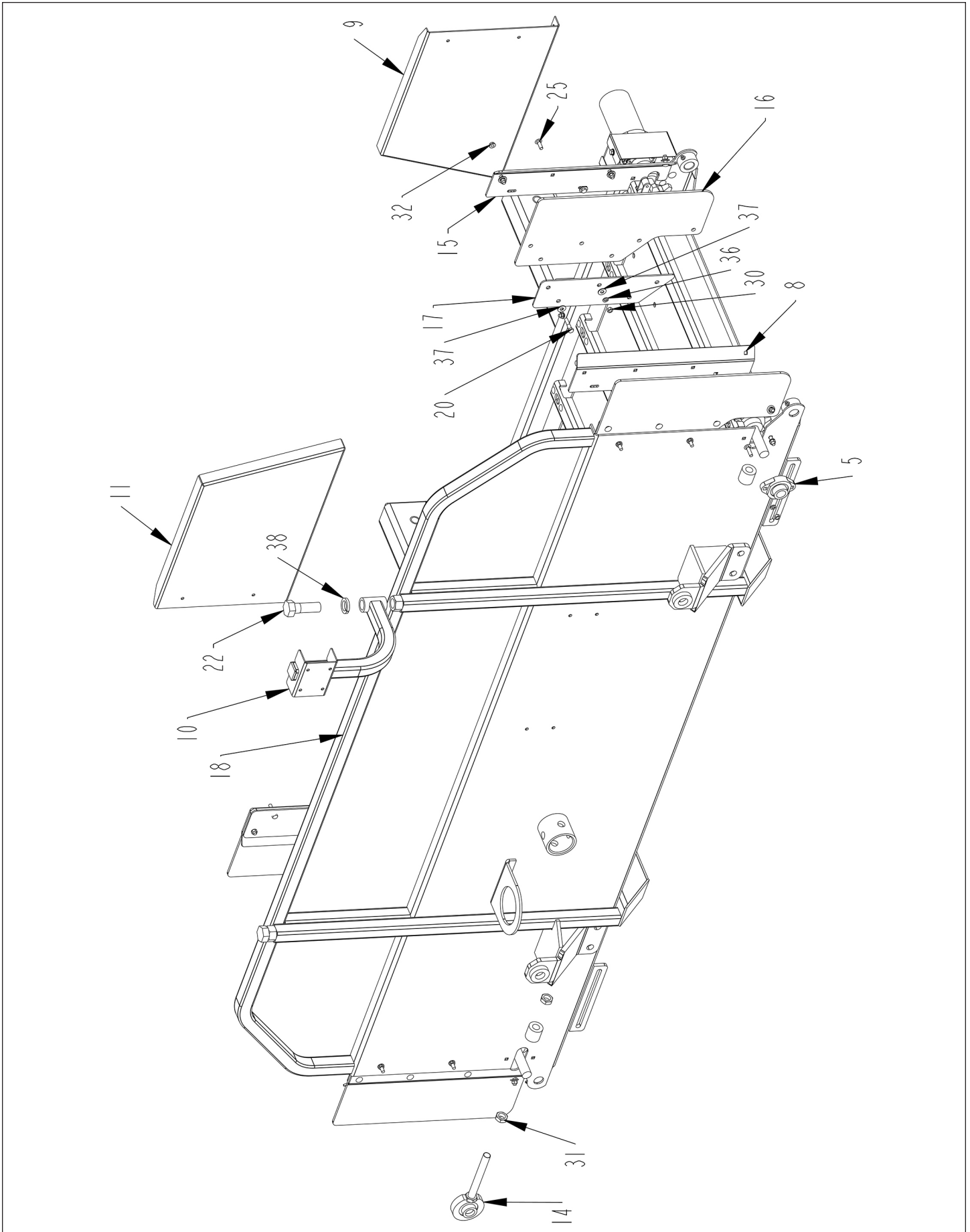

**MAIN CONVEYOR ASSEMBLY-4704972 - SUB ASSEMBLY 2
(USE W/LH DISCHARGE)**

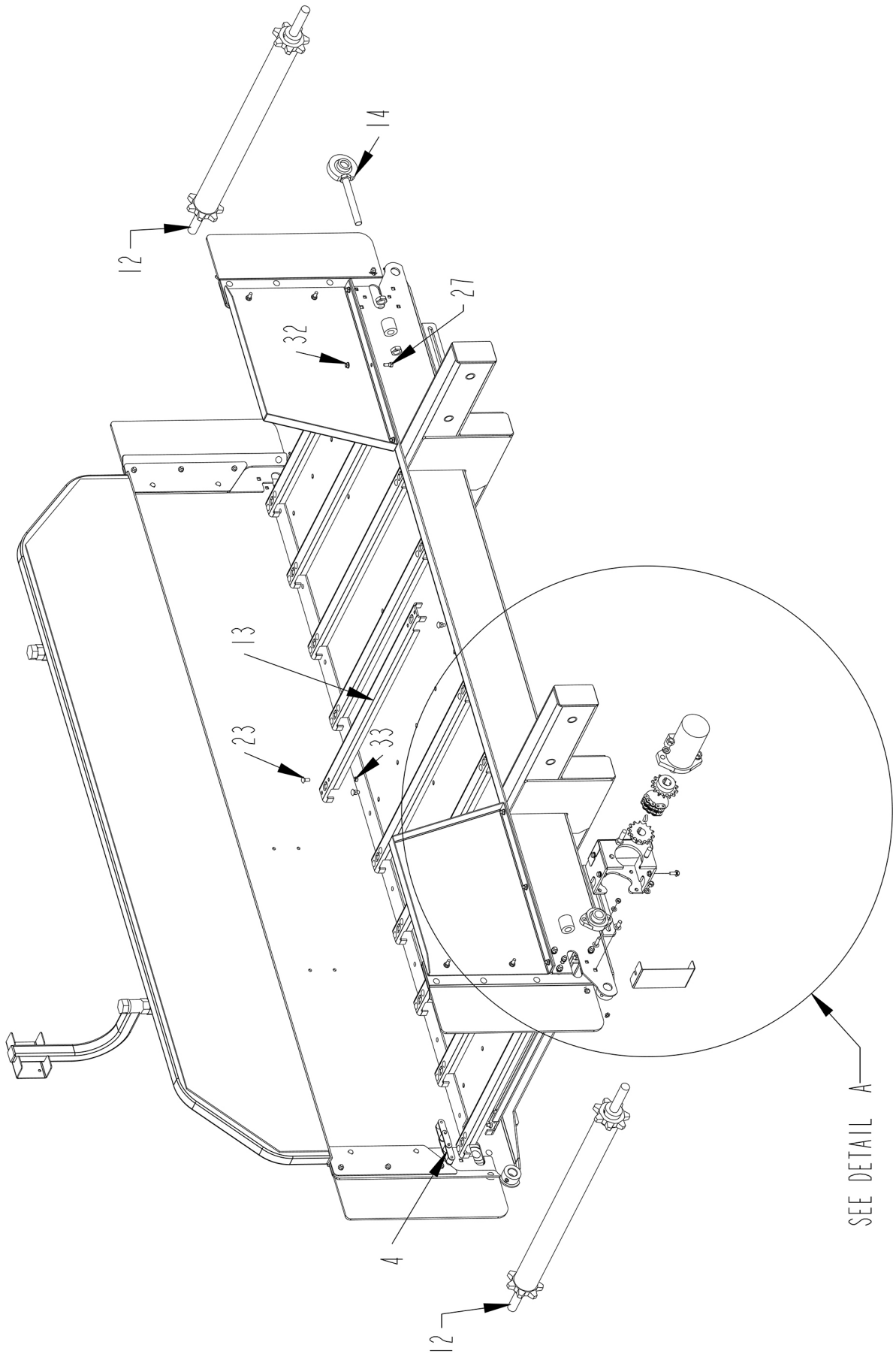

**MAIN CONVEYOR ASSEMBLY-4704972 - DETAIL A
(USE W/LH DISCHARGE)**

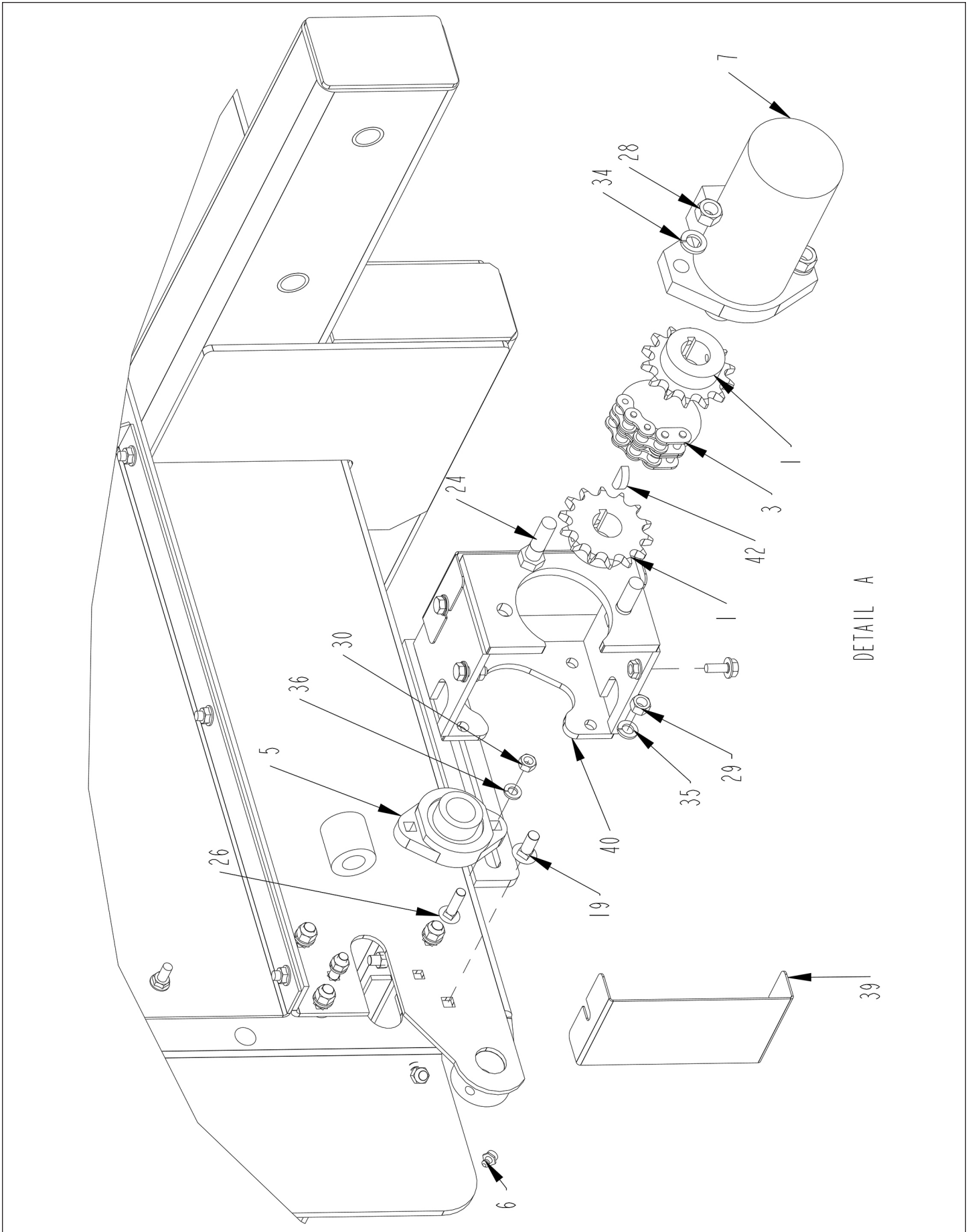

**MAIN CONVEYOR ASSEMBLY-4704972 - PARTS LIST
(USE W/LH DISCHARGE)**

ITEM	PART	QTY.	PART DESCRIPTION
1	1000029	2	SPKT\50\B\14\1\1/4KW
2	1100026	1	CHAIN\50DBL\13
3	1100099	1	CHAIN\50DBL\CL
4	1100256	2	CHAIN\620CA\120\W\ATTCH
5	2000310	2	BRG\FLG\CAST\1\2BOLT
6	3800043	4	FTG\LUB\1/8MPXZRK\SHORT
7	3900032	1	MOTOR\HYD\22.6\H
8	4704375	2	SH\DEFL\MAIN\CNVYR\RH
9	4704378	1	EXT\MAIN\CNVYR\LH
10	4704388	1	BRKT\IND\SCALE
11	4704519	1	EXT\MAIN\CNVYR\RH
12	4704576	2	SHAFT\ASSY\CNVYR\CMF
13	4704580	20	SLAT\CHAIN\CNVYR\CMF
14	4704585	2	BRG\ASSY\CNVYR\CMF
15	4704592	2	SH\DEFL\MAIN\CNVYR\LH
16	4704598	4	BELT\GUIDE\MATL\HINGE
17	4704859	4	DBLR\BELT\GUIDE\MATL\HINGE
18	4704970	1	CNVYR\MAIN\WELD\CMF
19	4800053	4	BOLT\CRG\3/8X1\NC
20	4800081	8	BOLT\HEX\5/16X1-1/2
21	4800113	4	SCR\FLNG\SERR\5/16X3/4\TP
22	4800140	2	BOLT\HEX\1X3\NC
23	4800153	80	BOLT\CRG\5/16X3/4\NC
24	4800178	2	BOLT\HEX\1/2X1-3/4
25	4800473	16	BOLT\CRG\5/16X1\NC
26	4800474	4	BOLT\CRG\5/16X1-1/4\NC
27	4800643	6	BOLT\HEX\5/16X3/4
28	4900001	2	NUT\HEX\1/2\NC
29	4900002	4	NUT\HEX\3/8\NC
30	4900003	20	NUT\HEX\5/16\NC
31	4900104	6	NUT\JAM\3/4\NC
32	4900108	18	NUT\FLG\SERR\5/16\NC
33	4900142	80	NUT\TPLCK\5/16\NC
34	5000006	2	WASH\LOCK\1/2
35	5000019	4	WASH\LOCK\3/8
36	5000022	20	WASH\LOCK\5/16
37	5000023	24	WASH\FLAT\5/16
38	5000053	1	WASH\LOCK\1
39	5900071	2	SHLD\CPLR\CNVYR
40	5900072	1	MNT\MTR\CNVYR\EXT\CMF
41	5900073	2	SHAFT\WELD\CNVYR\CMF
42	6200011	1	KEY\WDF\1/4X1

4704972

CNVYR\ASSY\MAIN\CMF\LH

**OPTIONAL-LH DOGLEG DISCHARGE CONVEYOR
(FOR S.N. UP TO VM18004071)**

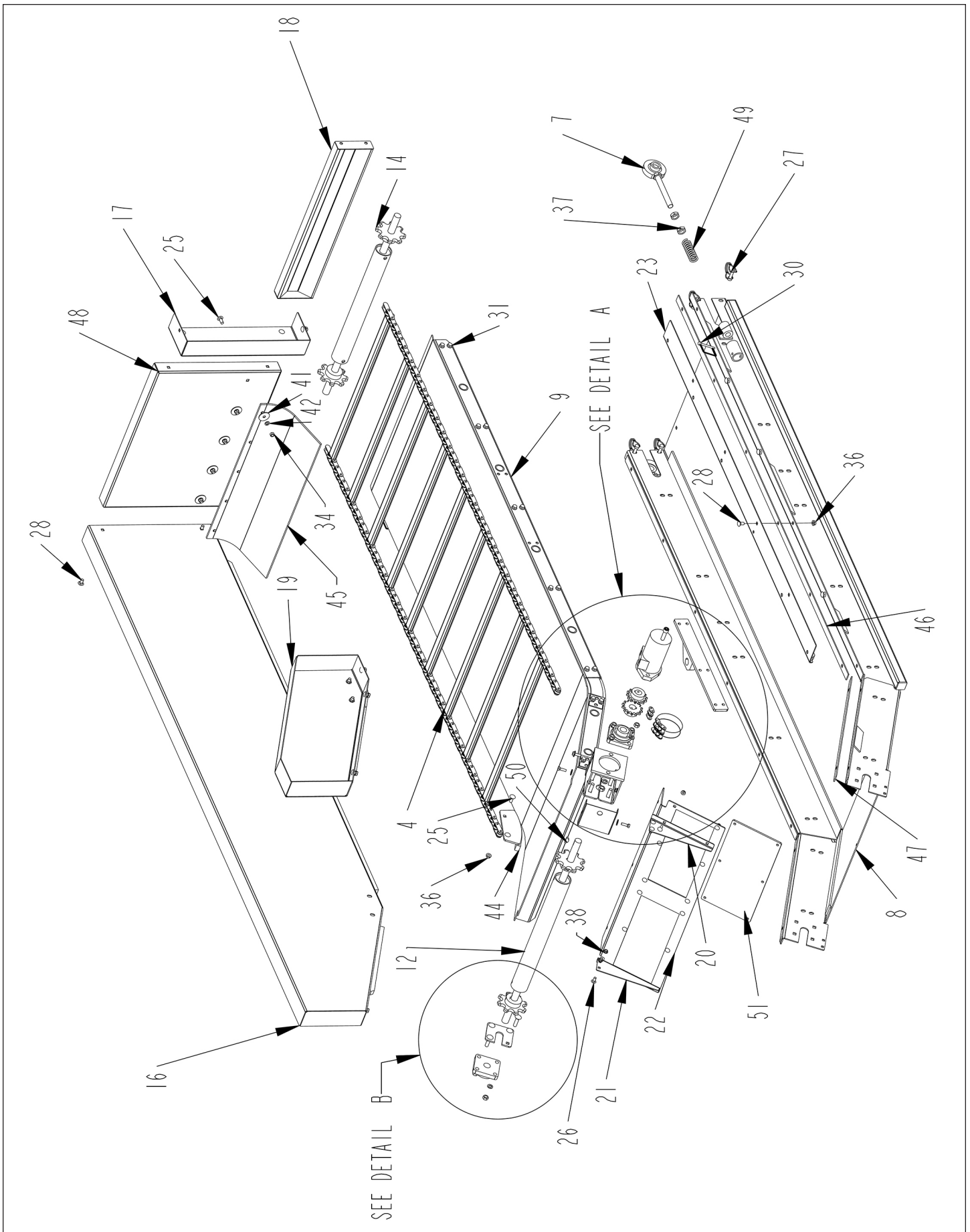

**OPTIONAL-LH DOGLEG DISCHARGE CONVEYOR PARTS LIST
(FOR S.N. UP TO VM18004071)**

ITEM	PART	QTY.	PART DESCRIPTION
1	100029	2	SPKT\50\B\14\1\1/4KW
2	110026	1	CHAIN\50DBL\13
3	110099	1	CHAIN\50DBL\CL
4	1100303	1	CHAIN\ASSY\2062H\140P\23\29" C-C
5	2000323	2	BRG\FLG\1\4BOLT
6	3900032	1	MOTOR\HYD\22.6\H
7	4704585	2	BRG\ASSY\CNVYR\CMF
8	4705179	1	WELD\FRM\DOG\CNVYR
9	4705181	1	DECK\DOG\CNVYR
10	4705184	1	MNT\CYL\DOG\CNVYR
11	4705188	1	MNT\MTR\CNVYR\DOG
12	4705191	1	SHAFT\ASSY\CNVYR\DOGCMF
13	4705192	2	COVER\CPLR\CHAIN\CNVYR
14	4705193	1	IDLER\ASSY\CNVYR\CMF
15	4705194	1	PL\BRG\SHIM
16	4705195	1	PANEL\FRNT\DOG\LH\CNVYR
17	4705198	1	PANEL\BACK\RIGHT\DOG\LH\CNVYR
18	4705199	1	COVER\CNVYR\DOGLEG
19	4705200	1	PANEL\BACK\LEFT\DOG\LH\CNVYR
20	4705351	1	SH\SIDE\L\RAMP\FRM\DOG
21	4705352	1	SH\SIDE\R\RAMP\FRM\DOG
22	4705353	1	SH\RAMP\FRM\DOG
23	4705527	1	SEAL\CHAIN\CNVYR\DOGLEG
24	4800013	4	BOLT\HEX\5/16X1
25	4800053	9	BOLT\CRG\3/8X1\NC
26	4800153	16	BOLT\CRG\5/16X3/4\NC
27	4800365	4	PIN\LNCH\3/8X1-1/2W/KEEPER
28	4800394	20	BOLT\CRG\3/8X3/4\NC
29	4800434	2	SCR\CAP\ALN\1/2X1-3/4\NC
30	4800911	2	PIN\LYNCH\1/4X2-1/2\
31	4800913	30	BOLT\FLG\SERR\3/8X1\NC
32	4800947	8	BOLT\CRG\7/16X2\NC
33	4900001	2	NUT\HEX\1/2\NC
34	4900002	5	NUT\HEX\3/8\NC
35	4900025	8	NUT\HEX\7/16\NC
36	4900076	56	NUT\FLG\SERR\3/8\NC
37	4900104	6	NUT\JAM\3/4\NC
38	4900108	20	NUT\FLG\SERR\5/16\NC
39	5000006	2	WASH\LOCK\1/2
40	5000015	8	WASH\LOCK\7/16
41	5000017	5	WASH\FLAT\FNDR\1.395X1-5/8X.090
42	5000019	5	WASH\LOCK\3/8
43	5000023	4	WASH\FLAT\5/16
44	5900026	2	SHOE\CHAIN\CNVYR\DOGLEG
45	5900040	1	BELT\COVER\SHAFT\CNVYR
46	5900055	2	SHIM\DOGLEG\LONG
47	5900056	2	SHIM\DOGLEG\SHORT
48	5900060	1	SH\PANEL\END\CNVYR\DOGLEG
49	6100076	2	SPRING\1-1/4ODX3-3/4 LX3/16WX10
50	6200011	1	KEY\WDF\1/4X1
51	7501271	2	MAG\PL\14X6X1-1/2

4705182

TBL\LEFT\DOG\CNVYR\CMF

**OPTIONAL-LH DOGLEG DISCHARGE CONVEYOR DETAILS A & B
(FOR S.N. UP TO VM18004071)**

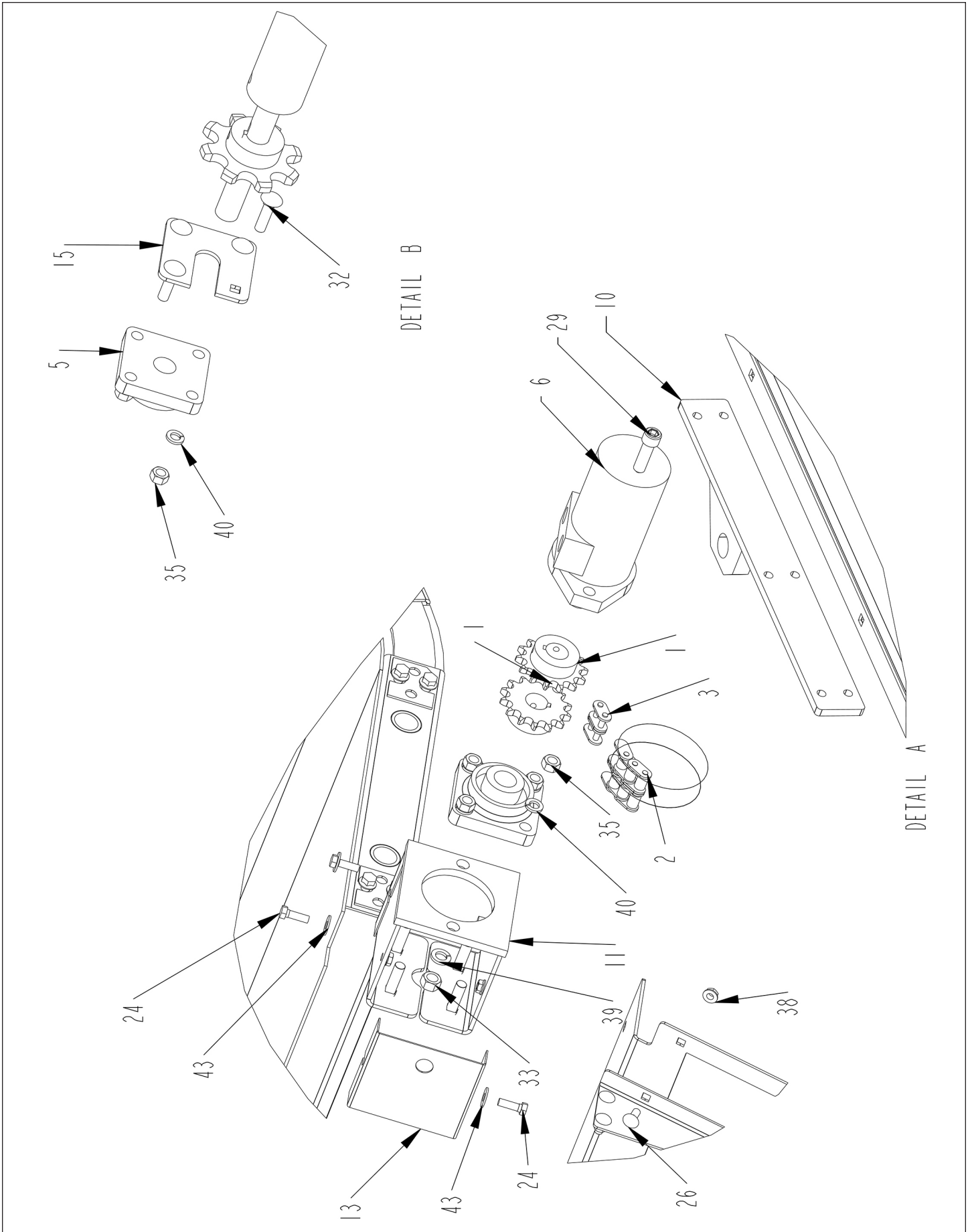

**OPTIONAL-LH DOGLEG DISCHARGE CONVEYOR DETAILS A & B
(FOR S.N. UP TO VM18004071)**

ITEM	PART	QTY.	PART DESCRIPTION
1	100029	2	SPKT\50\B\14\1\1/4KW
2	110026	1	CHAIN\50DBL\13
3	110099	1	CHAIN\50DBL\CL
4	1100303	1	CHAIN\ASSY\2062H\140P\23\29" C-C
5	2000323	2	BRG\FLG\1\4BOLT
6	3900032	1	MOTOR\HYD\22.6\H
7	4704585	2	BRG\ASSY\CNVYR\CMF
8	4705179	1	WELD\FRM\DOG\CNVYR
9	4705181	1	DECK\DOG\CNVYR
10	4705184	1	MNT\CYL\DOG\CNVYR
11	4705188	1	MNT\MTR\CNVYR\DOG
12	4705191	1	SHAFT\ASSY\CNVYR\DOGCMF
13	4705192	2	COVER\CPLR\CHAIN\CNVYR
14	4705193	1	IDLER\ASSY\CNVYR\CMF
15	4705194	1	PL\BRG\SHIM
16	4705195	1	PANEL\FRNT\DOG\LH\CNVYR
17	4705198	1	PANEL\BACK\RIGHT\DOG\LH\CNVYR
18	4705199	1	COVER\CNVYR\DOGLEG
19	4705200	1	PANEL\BACK\LEFT\DOG\LH\CNVYR
20	4705351	1	SH\SIDE\L\RAMP\FRM\DOG
21	4705352	1	SH\SIDE\R\RAMP\FRM\DOG
22	4705353	1	SH\RAMP\FRM\DOG
23	4705527	1	SEAL\CHAIN\CNVYR\DOGLEG
24	4800013	4	BOLT\HEX\5/16X1
25	4800053	9	BOLT\CRG\3/8X1\NC
26	4800153	16	BOLT\CRG\5/16X3/4\NC
27	4800365	4	PIN\LNCH\3/8X1-1/2W/KEEPER
28	4800394	20	BOLT\CRG\3/8X3/4\NC
29	4800434	2	SCR\CAP\ALN\1/2X1-3/4\NC
30	4800911	2	PIN\LYNCH\1/4X2-1/2\
31	4800913	30	BOLT\FLG\SERR\3/8X1\NC
32	4800947	8	BOLT\CRG\7/16X2\NC
33	4900001	2	NUT\HEX\1/2\NC
34	4900002	5	NUT\HEX\3/8\NC
35	4900025	8	NUT\HEX\7/16\NC
36	4900076	56	NUT\FLG\SERR\3/8\NC
37	4900104	6	NUT\JAM\3/4\NC
38	4900108	20	NUT\FLG\SERR\5/16\NC
39	5000006	2	WASH\LOCK\1/2
40	5000015	8	WASH\LOCK\7/16
41	5000017	5	WASH\FLAT\FNDR\1.395X1-5/8X.090
42	5000019	5	WASH\LOCK\3/8
43	5000023	4	WASH\FLAT\5/16
44	5900026	2	SHOE\CHAIN\CNVYR\DOGLEG
45	5900040	1	BELT\COVER\SHAFT\CNVYR
46	5900055	2	SHIM\DOGLEG\LONG
47	5900056	2	SHIM\DOGLEG\SHORT
48	5900060	1	SH\PANEL\END\CNVYR\DOGLEG
49	6100076	2	SPRING\1-1/4ODX3-3/4 LX3/16WX10
50	6200011	1	KEY\WDF\1/4X1
51	7501271	2	MAG\PL\14X6X1-1/2

4705182

TBL\LEFT\DOG\CNVYR\CMF

**OPTIONAL-LH DOGLEG DISCHARGE CONVEYOR COMPLETE
(FOR S.N. UP TO VM18004071)**

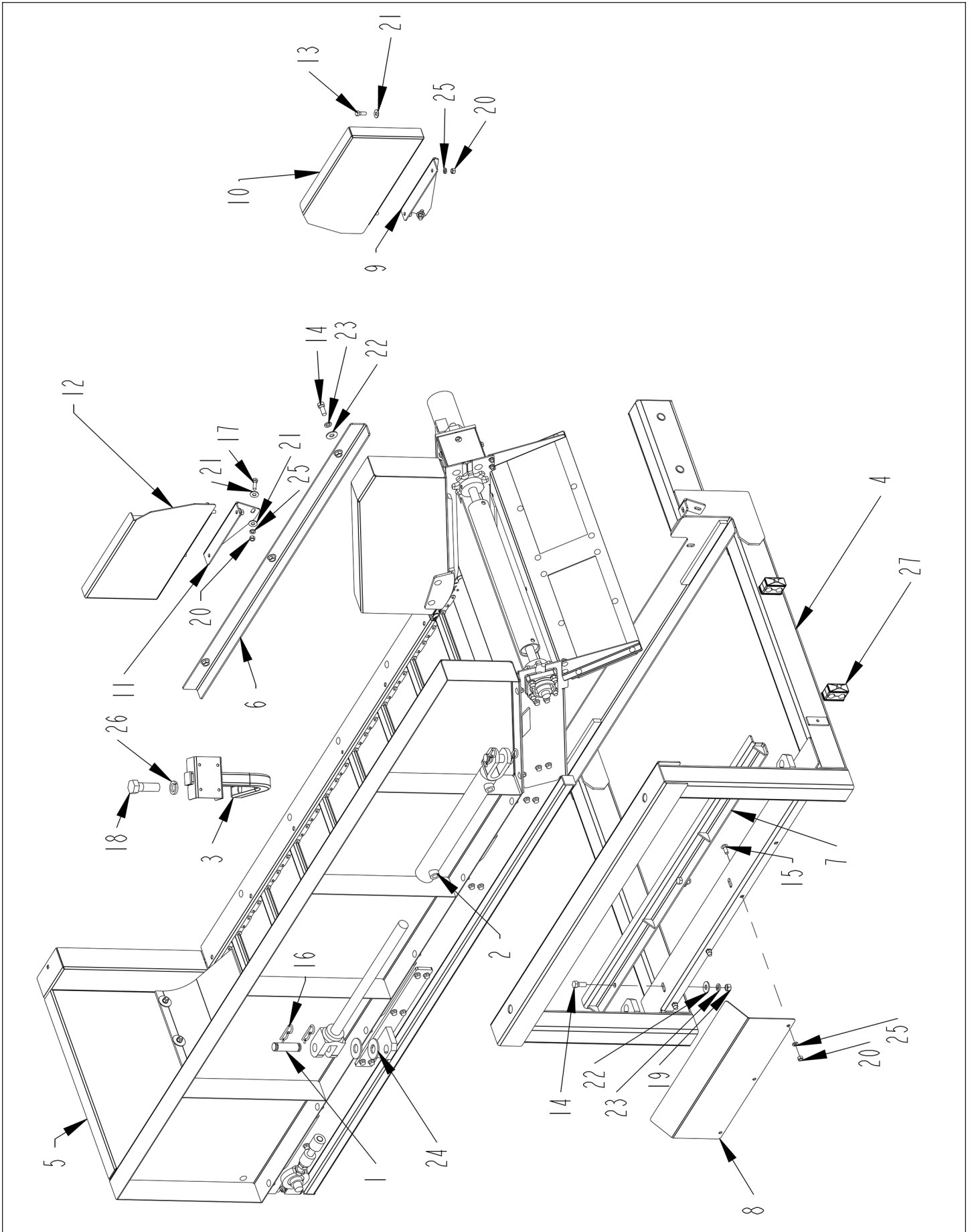

**OPTIONAL-LH DOGLEG DISCHARGE CONVEYOR COMPLETE
(FOR S.N. UP TO VM18004071)**

ITEM	PART	QTY.	PART DESCRIPTION
1	4100030	2	PIN 1" X 3-1/2" HYD. CYL.
2	4100284	1	CYL\HYD\2X16\1-1/4RD\WELDE
3	4704388	1	BRKT\IND\SCALE
4	4705178	1	FRM\DOGLEG\CNVYR\CMF
5	4705182	1	TBL\LH\DOG\CNVYR\CMF
6	4705183	1	PL\PRESS\DOG\CNVYR
7	4705185	1	CLAMP\DOGLEG\CNVYR
8	4705390	1	COVER\ROD\CYL
9	4705393	1	BRKT\PANEL\LEFT\DOG\CNVYR
10	4705394	1	PANEL\LEFT\DOG\CNVYR
11	4705395	1	BRKT\PANEL\RIGHT\DOG\CNVYR
12	4705396	1	PANEL\RIGHT\DOG\CNVYR
13	4800003	2	BOLT\HEX\3/8X1
14	4800018	6	BOLT\HEX\1/2X1-1/4
15	4800053	12	BOLT\CRG\3/8X1\NC
16	4800056	4	PIN\HAIR\3/16(#3)
17	4800098	4	BOLT\HEX\3/8X1-1/4\NC
18	4800140	1	BOLT\HEX\1X3\NC
19	4900001	5	NUT\HEX\1/2\NC
20	4900002	14	NUT\HEX\3/8\NC
21	5000001	10	WASH\FLAT\3/8
22	5000004	6	WASH\FLAT\1/2
23	5000006	8	WASH\LOCK\1/2
24	5000014	2	WASH\FLAT\1
25	5000019	14	WASH\LOCK\3/8
26	5000053	1	WASH\LOCK\1
27	7501525	4	CLAMP\HOSE\1/2\2

4705177

CMF\CNVYR\DOGLEG\LEFT\ASSY

**OPTIONAL-RH DOGLEG DISCHARGE CONVEYOR
(FOR S.N. UP TO VM18004071)**

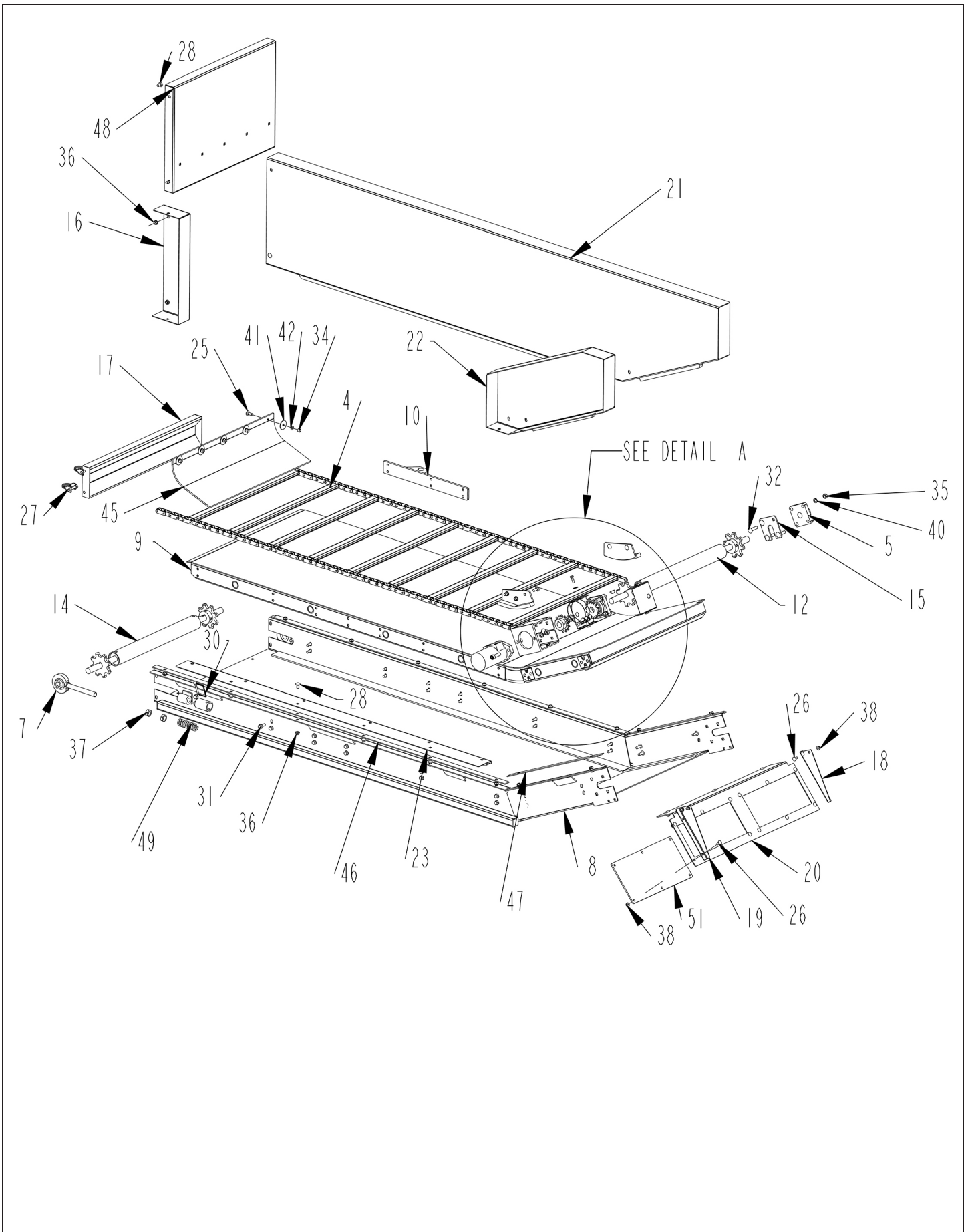

**OPTIONAL-RH DOGLEG DISCHARGE CONVEYOR PARTS LIST
(FOR S.N. UP TO VM18004071)**

ITEM	PART	QTY.	PART DESCRIPTION
1	100029	2	SPKT\50\B\14\1\1/4KW
2	110026	1	CHAIN\50DBL\13
3	110099	1	CHAIN\50DBL\CL
4	1100303	1	CHAIN\ASSY\2062H\140P\23\29" C-C
5	2000323	2	BRG\FLG\1\4BOLT
6	3900032	1	MOTOR\HYD\22.6\H
7	4704585	2	BRG\ASSY\CNVYR\CMF
8	4705179	1	WELD\FRM\DOG\CNVYR
9	4705181	1	DECK\DOG\CNVYR
10	4705184	1	MNT\CYL\DOG\CNVYR
11	4705188	1	MNT\MTR\CNVYR\DOG
12	4705191	1	SHAFT\ASSY\CNVYR\DOGC MF
13	4705192	2	COVER\CPLR\CHAIN\CNVYR
14	4705193	1	IDLER\ASSY\CNVYR\CMF
15	4705194	1	PL\BRG\SHIM
16	4705198	1	PANEL\BACK\RIGHT\DOG\LH\CNVYR
17	4705199	1	COVER\CNVYR\DOGLEG
18	4705351	1	SH\SIDE\L\RAMP\FRM\DOG
19	4705352	1	SH\SIDE\R\RAMP\FRM\DOG
20	4705353	1	SH\RAMP\FRM\DOG
21	4705524	1	PANEL\FRNT\DOG\RH\CNVYR
22	4705525	1	PANEL\BACK\RIGHT\DOG\RH\CNVYR
23	4705527	1	SEAL\CHAIN\CNVYR\DOGLEG
24	4800013	4	BOLT\HEX\5/16X1
25	4800053	9	BOLT\CRG\3/8X1\NC
26	4800153	16	BOLT\CRG\5/16X3/4\NC
27	4800365	4	PIN\LNCH\3/8X1-1/2W/KEEPER
28	4800394	23	BOLT\CRG\3/8X3/4\NC
29	4800434	2	SCR\CAP\ALN\1/2X1-3/4\NC
30	4800911	2	PIN\LYNCH\1/4X2-1/2\
31	4800913	32	BOLT\FLG\SERR\3/8X1\NC
32	4800947	8	BOLT\CRG\7/16X2\NC
33	4900001	2	NUT\HEX\1/2\NC
34	4900002	5	NUT\HEX\3/8\NC
35	4900025	8	NUT\HEX\7/16\NC
36	4900076	59	NUT\FLG\SERR\3/8\NC
37	4900104	6	NUT\JAM\3/4\NC
38	4900108	20	NUT\FLG\SERR\5/16\NC
39	5000006	2	WASH\LOCK\1/2
40	5000015	8	WASH\LOCK\7/16
41	5000017	5	WASH\FLAT\FNDR\.395X1-5/8X.090
42	5000019	5	WASH\LOCK\3/8
43	5000023	4	WASH\FLAT\5/16
44	5900026	2	SHOE\CHAIN\CNVYR\DOGLEG
45	5900040	1	BELT\COVER\SHAFT\CNVYR
46	5900055	2	SHIM\DOGLEG\LONG
47	5900056	2	SHIM\DOGLEG\SHORT
48	5900060	1	SH\PANEL\END\CNVYR\DOGLEG
49	6100076	2	SPRING\1-1/4ODX3-3/4 LX3/16WX10
50	6200011	1	KEY\WDF\1/4X1
51	7501271	2	MAG\PL\14X6X1-1/2

4705523

TBL\RIGHT\DOG\CNVYR\CMF

**OPTIONAL-RH DOGLEG DISCHARGE CONVEYOR DETAIL A
(FOR S.N. UP TO VM18004071)**

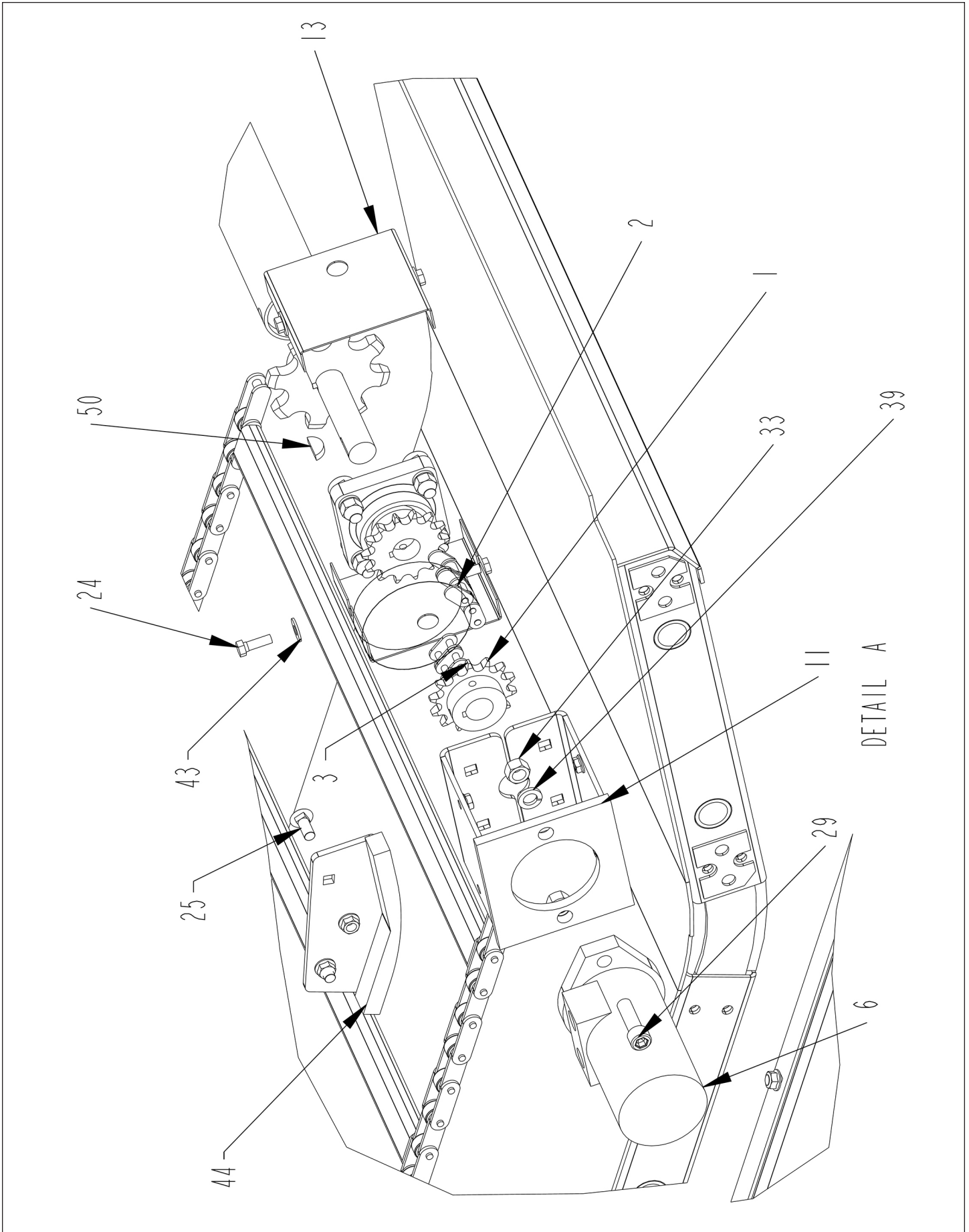

DETAIL A

**OPTIONAL-RH DOGLEG DISCHARGE CONVEYOR DETAIL A
(FOR S.N. UP TO VM18004071)**

ITEM	PART	QTY.	PART DESCRIPTION
1	100029	2	SPKT\50\B\14\1\1/4KW
2	110026	1	CHAIN\50DBL\13
3	110099	1	CHAIN\50DBL\CL
4	1100303	1	CHAIN\ASSY\2062H\140P\23\29" C-C
5	2000323	2	BRG\FLG\1\4BOLT
6	3900032	1	MOTOR\HYD\22.6\H
7	4704585	2	BRG\ASSY\CNVYR\CMF
8	4705179	1	WELD\FRM\DOG\CNVYR
9	4705181	1	DECK\DOG\CNVYR
10	4705184	1	MNT\CYL\DOG\CNVYR
11	4705188	1	MNT\MTR\CNVYR\DOG
12	4705191	1	SHAFT\ASSY\CNVYR\DOGC MF
13	4705192	2	COVER\CPLR\CHAIN\CNVYR
14	4705193	1	IDLER\ASSY\CNVYR\CMF
15	4705194	1	PL\BRG\SHIM
16	4705198	1	PANEL\BACK\RIGHT\DOG\LH\CNVYR
17	4705199	1	COVER\CNVYR\DOGLEG
18	4705351	1	SH\SIDE\L\RAMP\FRM\DOG
19	4705352	1	SH\SIDE\R\RAMP\FRM\DOG
20	4705353	1	SH\RAMP\FRM\DOG
21	4705524	1	PANEL\FRNT\DOG\RH\CNVYR
22	4705525	1	PANEL\BACK\RIGHT\DOG\RH\CNVYR
23	4705527	1	SEAL\CHAIN\CNVYR\DOGLEG
24	4800013	4	BOLT\HEX\5/16X1
25	4800053	9	BOLT\CRG\3/8X1\NC
26	4800153	16	BOLT\CRG\5/16X3/4\NC
27	4800365	4	PIN\LNCH\3/8X1-1/2W/KEEPER
28	4800394	23	BOLT\CRG\3/8X3/4\NC
29	4800434	2	SCR\CAP\ALN\1/2X1-3/4\NC
30	4800911	2	PIN\LYNCH\1/4X2-1/2\
31	4800913	32	BOLT\FLG\SERR\3/8X1\NC
32	4800947	8	BOLT\CRG\7/16X2\NC
33	4900001	2	NUT\HEX\1/2\NC
34	4900002	5	NUT\HEX\3/8\NC
35	4900025	8	NUT\HEX\7/16\NC
36	4900076	59	NUT\FLG\SERR\3/8\NC
37	4900104	6	NUT\JAM\3/4\NC
38	4900108	20	NUT\FLG\SERR\5/16\NC
39	5000006	2	WASH\LOCK\1/2
40	5000015	8	WASH\LOCK\7/16
41	5000017	5	WASH\FLAT\FNDR\395X1-5/8X.090
42	5000019	5	WASH\LOCK\3/8
43	5000023	4	WASH\FLAT\5/16
44	5900026	2	SHOE\CHAIN\CNVYR\DOGLEG
45	5900040	1	BELT\COVER\SHAFT\CNVYR
46	5900055	2	SHIM\DOGLEG\LONG
47	5900056	2	SHIM\DOGLEG\SHORT
48	5900060	1	SH\PANEL\END\CNVYR\DOGLEG
49	6100076	2	SPRING\1-1/4ODX3-3/4 LX3/16WX10
50	6200011	1	KEY\WDF\1/4X1
51	7501271	2	MAG\PL\14X6X1-1/2
	4705523		TBL\RIGHT\DOG\CNVYR\CMF

**OPTIONAL-RH DOGLEGG DISCHARGE CONVEYOR COMPLETE
(FOR S.N. UP TO VM18004071)**

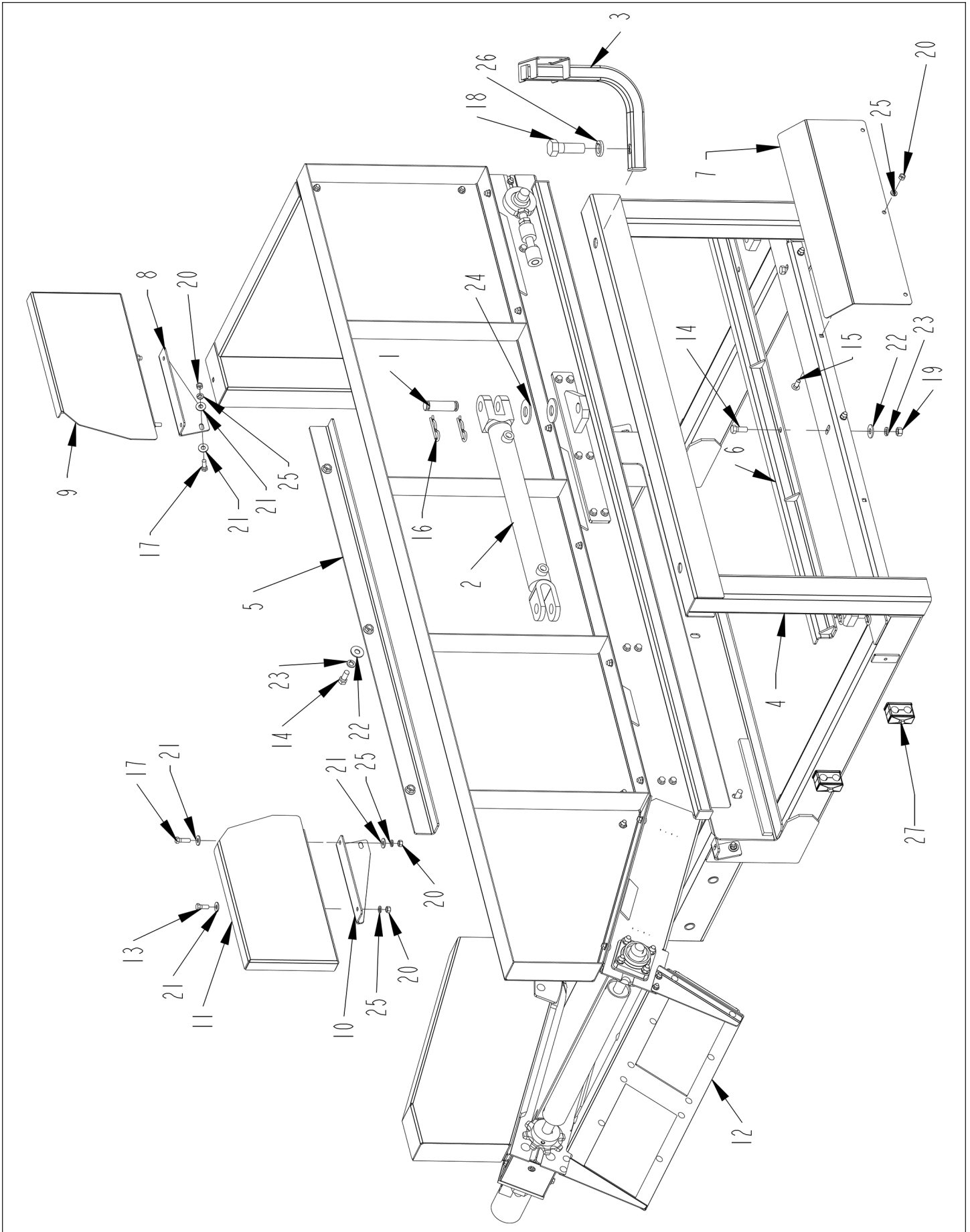

**OPTIONAL-RH DOGLEG DISCHARGE CONVEYOR COMPLETE
(FOR S.N. UP TO VM18004071)**

ITEM	PART	QTY.	PART DESCRIPTION
1	4100030	2	PIN 1" X 3-1/2" HYD. CYL.
2	4100284	1	CYL\HYD\2X16\1-1/4RD\WELDE
3	4704388	1	BRKT\IND\SCALE
4	4705178	1	FRM\DOGLEG\CNVYR\CMF
5	4705183	1	PL\PRESS\DOG\CNVYR
6	4705185	1	CLAMP\DOGLEG\CNVYR
7	4705390	1	COVER\ROD\CYL
8	4705393	1	BRKT\PANEL\LEFT\DOG\CNVYR
9	4705394	1	PANEL\LEFT\DOG\CNVYR
10	4705395	1	BRKT\PANEL\RIGHT\DOG\CNVYR
11	4705396	1	PANEL\RIGHT\DOG\CNVYR
12	4705523	1	TBL\RH\DOG\CNVYR\CMF
13	4800003	2	BOLT\HEX\3/8X1
14	4800018	6	BOLT\HEX\1/2X1-1/4
15	4800053	12	BOLT\CRG\3/8X1\NC
16	4800056	4	PIN\HAIR\3/16(#3)
17	4800098	4	BOLT\HEX\3/8X1-1/4\NC
18	4800140	1	BOLT\HEX\1X3\NC
19	4900001	5	NUT\HEX\1/2\NC
20	4900002	14	NUT\HEX\3/8\NC
21	5000001	10	WASH\FLAT\3/8
22	5000004	6	WASH\FLAT\1/2
23	5000006	8	WASH\LOCK\1/2
24	5000014	2	WASH\FLAT\1
25	5000019	14	WASH\LOCK\3/8
26	5000053	1	WASH\LOCK\1
27	7501525	4	CLAMP\HOSE\1/2\2

4705526

CMF\CNVYR\DOGLEG\RIGHT\ASSY

OPTIONAL DOGGLE CONVEYOR #1 (FOR S.N. VM20004171 & UP)

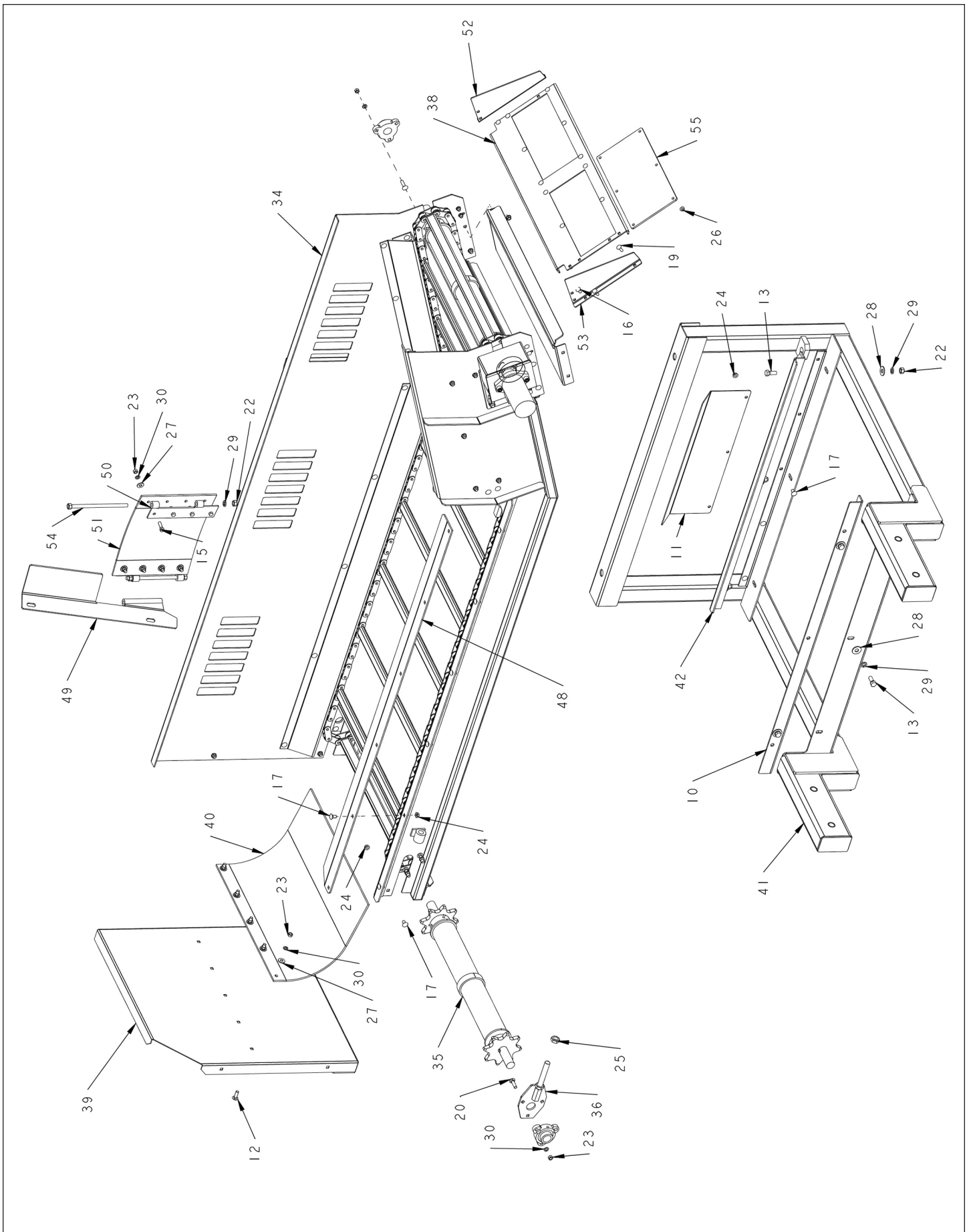

OPTIONAL DOGLEG CONVEYOR #1 (FOR S.N. VM20004171 & UP)

ITEM	PART	QTY.	PART DESCRIPTION
1	100029	1	SPKT\50\B\14\1\1\4KW
2	1000169	1	SPKT\50\B\14\1-1\4\1\4KW
3	1100026	1	CHAIN\50DBL\13
4	1100099	1	CHAIN\50DBL\CL
5	1100331	1	CHAIN\ASSY\2082H\18_SLAT
6	2000333	4	BRG\FLG\CAST\1-1\4\3-BOLT
7	3900032	1	MOTOR\HYD\22.6\H
8	4100030	2	PIN 1" X 3-1/2" HYD. CYL.
9	4100284	1	CYL\HYD\2X16\1-1\4RD\WELDE
10	4705183	1	PL\PRESS\DOG\CNVYR
11	4705390	1	COVER\ROD\CYL
12	4800012	12	BOLT\CRG\3\8X1-1\4\NC
13	4800018	6	BOLT\HEX\1\2X1-1\4
14	4800056	4	PIN\HAIR\3\16(#3)
15	4800098	8	BOLT\HEX\3\8X1-1\4\NC
16	4800153	6	BOLT\CRG\5\16X3\4\NC
17	4800394	33	BOLT\CRG\3\8X3\4\NC
18	4800434	2	SCR\CAP\ALN\1\2X1-3\4\NC
19	4800473	12	BOLT\CRG\5\16X1\NC
20	4800477	12	BOLT\CRG\3\8X1-1\2\NC
21	4800481	4	BOLT\CRG\1\2X1-1\4\NC
22	4900001	13	NUT\HEX\1\2\NC
23	4900002	32	NUT\HEX\3\8\NC
24	4900076	35	NUT\FLG\SERR\3\8\NC
25	4900104	4	NUT\JAM\3\4\NC
26	4900108	18	NUT\FLG\SERR\5\16\NC
27	5000001	13	WASH\FLAT\3\8
28	5000004	6	WASH\FLAT\1\2
29	5000006	14	WASH\LOCK\1\2
30	5000019	32	WASH\LOCK\3\8
31	5900160	1	COVER\CPLR\MTR
32	5900182	1	CNVYR\DGLG\2082\ASSY
33	5900183	1	SHFT\DRV\DGLG\2082\ASSY
34	5900186	1	CNVYR\DGLG\WELD
35	5900188	1	SHFT\IDL\DGLG\2082\ASSY
36	5900189	2	MNT\BRG\TNSN
37	5900190	1	BRKT\MTR\DGLG
38	5900191	1	SH\RAMP\MAG\DGLG
39	5900193	1	DOOR\DGLG
40	5900194	1	BELT\COVER\SHAFT\CNVYR
41	5900195	1	MNT\DGLG\CNVYR\CMF
42	5900196	1	CLMP\DGLG
43	5900197	1	GUIDE\CHAIN\FRNT\DGLG
44	5900198	1	GUIDE\CHAIN\REAR\DGLG
45	5900199	1	COVER\CHAIN\FRNT\DGLG
46	5900200	2	COVER\CHAIN\LEG\DGLG
47	5900201	1	PANEL\FRM\DGLG
48	5900202	1	SH\COVER\CHAIN\DGLG
49	5900203	1	MNT\TARP\FRM\
50	5900204	2	END\MNT\TARP
51	5900205	1	BELT\BACK\DGLG
52	5900210	1	SH\RAMP\L\DGLG
53	5900211	1	SH\RAMP\R\DGLG
54	5900212	2	BOLT\HINGE\BELT
55	7501271	2	MAG\PL\14X6X1-1\2

5900182

CNVYR\DGLG\2082\ASSY

OPTIONAL DOGLEG CONVEYOR #2 (FOR S.N. VM20004171 & UP)

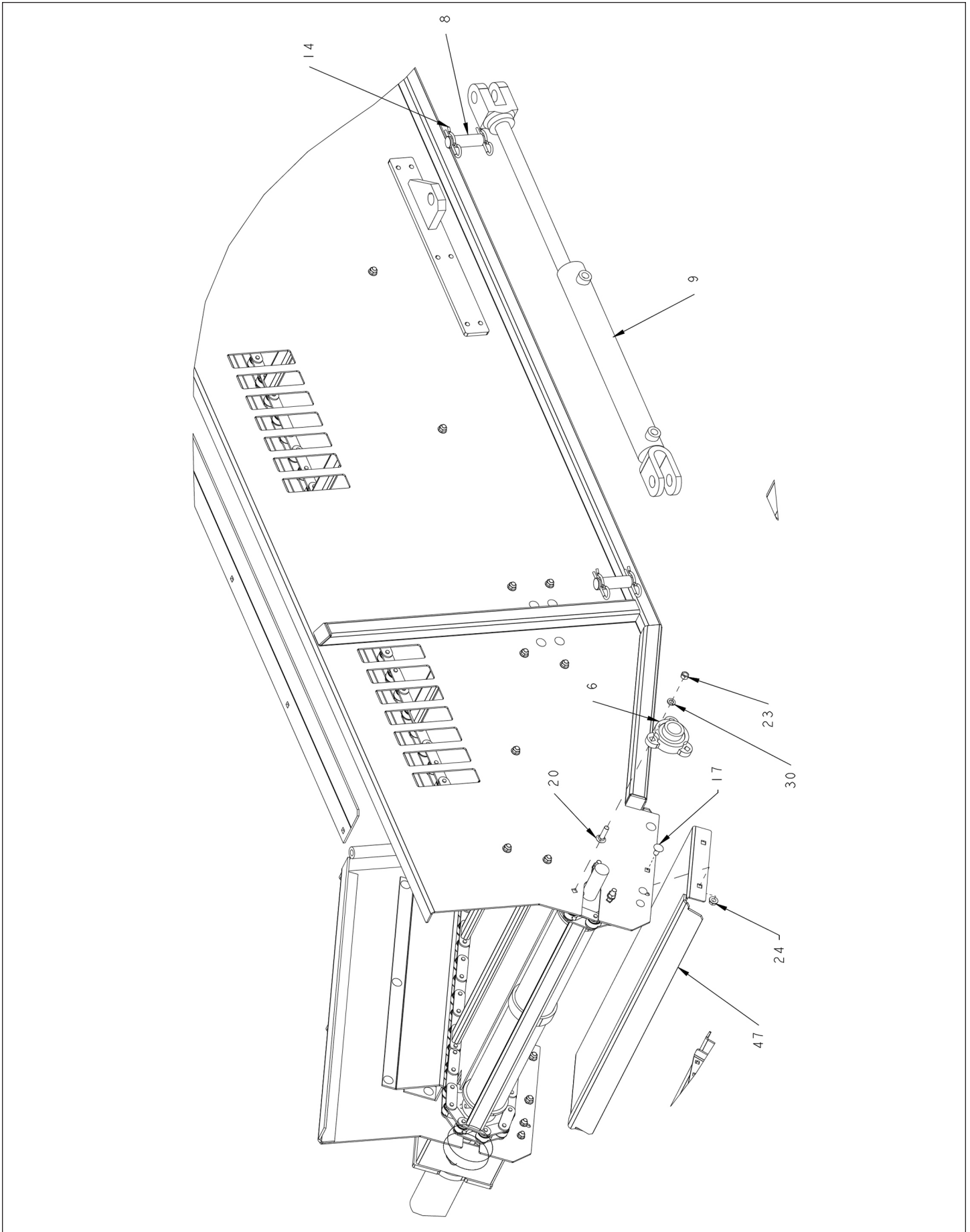

OPTIONAL DOGLEG CONVEYOR #2 (FOR S.N. VM20004171 & UP)

ITEM	PART	QTY.	PART DESCRIPTION
1	100029	1	SPKT\50\B\14\1\1\4KW
2	1000169	1	SPKT\50\B\14\1-1\4\1\4KW
3	1100026	1	CHAIN\50DBL\13
4	1100099	1	CHAIN\50DBL\CL
5	1100331	1	CHAIN\ASSY\2082H\18_SLAT
6	2000333	4	BRG\FLG\CAST\1-1\4\3-BOLT
7	3900032	1	MOTOR\HYD\22.6\H
8	4100030	2	PIN 1" X 3-1/2" HYD. CYL.
9	4100284	1	CYL\HYD\2X16\1-1\4RD\WELDE
10	4705183	1	PL\PRESS\DOG\CNVYR
11	4705390	1	COVER\ROD\CYL
12	4800012	12	BOLT\CRG\3\8X1-1\4\NC
13	4800018	6	BOLT\HEX\1\2X1-1\4
14	4800056	4	PIN\HAIR\3\16(#3)
15	4800098	8	BOLT\HEX\3\8X1-1\4\NC
16	4800153	6	BOLT\CRG\5\16X3\4\NC
17	4800394	33	BOLT\CRG\3\8X3\4\NC
18	4800434	2	SCR\CAP\ALN\1\2X1-3\4\NC
19	4800473	12	BOLT\CRG\5\16X1\NC
20	4800477	12	BOLT\CRG\3\8X1-1\2\NC
21	4800481	4	BOLT\CRG\1\2X1-1\4\NC
22	4900001	13	NUT\HEX\1\2\NC
23	4900002	32	NUT\HEX\3\8\NC
24	4900076	35	NUT\FLG\SERR\3\8\NC
25	4900104	4	NUT\JAM\3\4\NC
26	4900108	18	NUT\FLG\SERR\5\16\NC
27	5000001	13	WASH\FLAT\3\8
28	5000004	6	WASH\FLAT\1\2
29	5000006	14	WASH\LOCK\1\2
30	5000019	32	WASH\LOCK\3\8
31	5900160	1	COVER\CPLR\MTR
32	5900182	1	CNVYR\DGLG\2082\ASSY
33	5900183	1	SHFT\DRV\DGLG\2082\ASSY
34	5900186	1	CNVYR\DGLG\WELD
35	5900188	1	SHFT\IDL\DGLG\2082\ASSY
36	5900189	2	MNT\BRG\TNSN
37	5900190	1	BRKT\MTR\DGLG
38	5900191	1	SH\RAMP\MAG\DGLG
39	5900193	1	DOOR\DGLG
40	5900194	1	BELT\COVER\SHAFT\CNVYR
41	5900195	1	MNT\DGLG\CNVYR\CMF
42	5900196	1	CLMP\DGLG
43	5900197	1	GUIDE\CHAIN\FRNT\DGLG
44	5900198	1	GUIDE\CHAIN\REAR\DGLG
45	5900199	1	COVER\CHAIN\FRNT\DGLG
46	5900200	2	COVER\CHAIN\LEG\DGLG
47	5900201	1	PANEL\FRM\DGLG
48	5900202	1	SH\COVER\CHAIN\DGLG
49	5900203	1	MNT\TARP\FRM\
50	5900204	2	END\MNT\TARP
51	5900205	1	BELT\BACK\DGLG
52	5900210	1	SH\RAMP\L\DGLG
53	5900211	1	SH\RAMP\R\DGLG
54	5900212	2	BOLT\HINGE\BELT
55	7501271	2	MAG\PL\14X6X1-1\2

5900182

CNVYR\DGLG\2082\ASSY

OPTIONAL DOGLEG CONVEYOR #3 (FOR S.N. VM20004171 & UP)

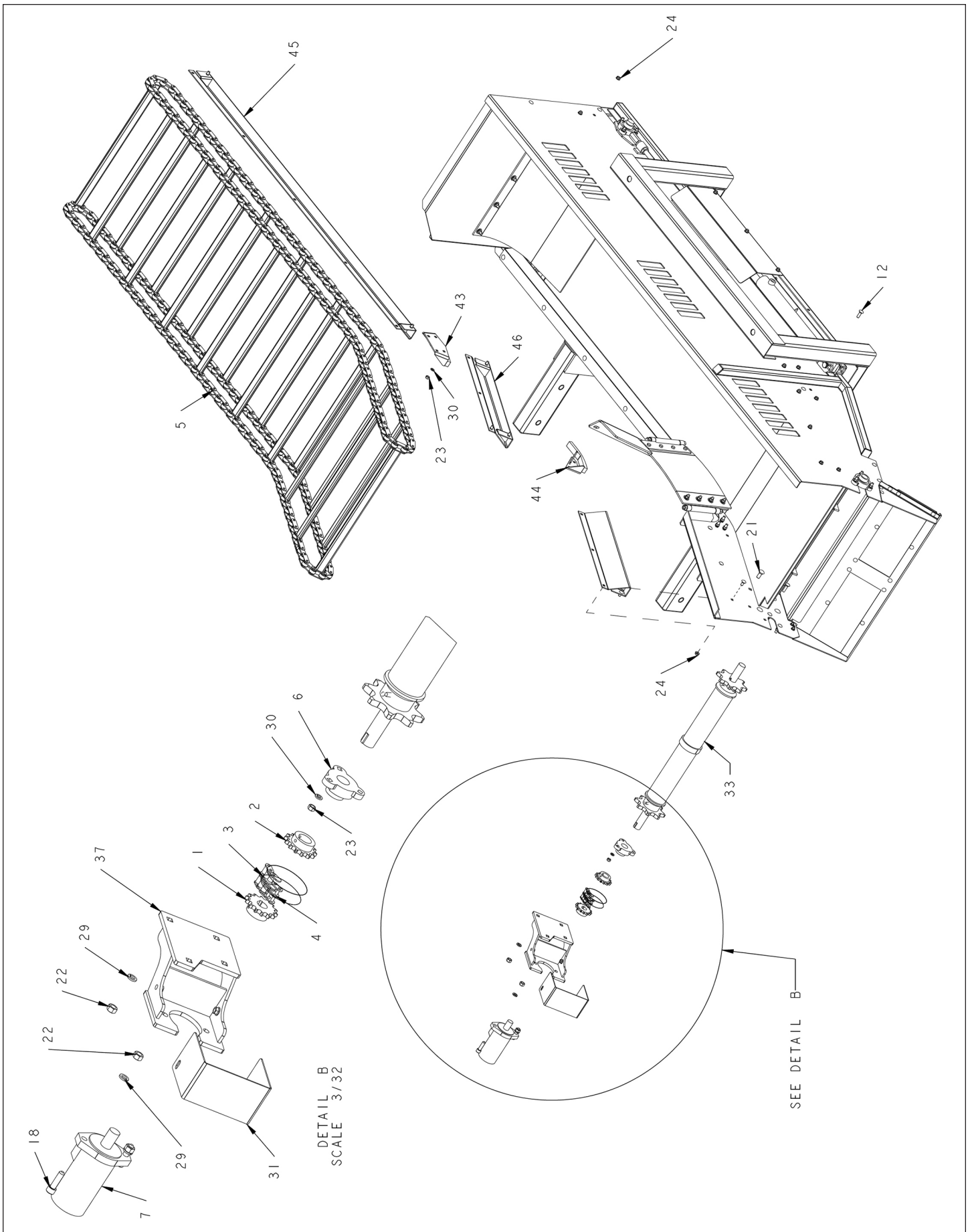

OPTIONAL DOGLEG CONVEYOR #3 (FOR S.N. VM20004171 & UP)

ITEM	PART	QTY.	PART DESCRIPTION
1	100029	1	SPKT\50\B\14\1\1\4KW
2	1000169	1	SPKT\50\B\14\1-1\4\1\4KW
3	1100026	1	CHAIN\50DBL\13
4	1100099	1	CHAIN\50DBL\CL
5	1100331	1	CHAIN\ASSY\2082H\18_SLAT
6	2000333	4	BRG\FLG\CAST\1-1\4\3-BOLT
7	3900032	1	MOTOR\HYD\22.6\H
8	4100030	2	PIN 1" X 3-1/2" HYD. CYL.
9	4100284	1	CYL\HYD\2X16\1-1\4RD\WELDE
10	4705183	1	PL\PRESS\DOG\CNVYR
11	4705390	1	COVER\ROD\CYL
12	4800012	12	BOLT\CRG\3\8X1-1\4\NC
13	4800018	6	BOLT\HEX\1\2X1-1\4
14	4800056	4	PIN\HAIR\3\16(#3)
15	4800098	8	BOLT\HEX\3\8X1-1\4\NC
16	4800153	6	BOLT\CRG\5\16X3\4\NC
17	4800394	33	BOLT\CRG\3\8X3\4\NC
18	4800434	2	SCR\CAP\ALN\1\2X1-3\4\NC
19	4800473	12	BOLT\CRG\5\16X1\NC
20	4800477	12	BOLT\CRG\3\8X1-1\2\NC
21	4800481	4	BOLT\CRG\1\2X1-1\4\NC
22	4900001	13	NUT\HEX\1\2\NC
23	4900002	32	NUT\HEX\3\8\NC
24	4900076	35	NUT\FLG\SERR\3\8\NC
25	4900104	4	NUT\JAM\3\4\NC
26	4900108	18	NUT\FLG\SERR\5\16\NC
27	5000001	13	WASH\FLAT\3\8
28	5000004	6	WASH\FLAT\1\2
29	5000006	14	WASH\LOCK\1\2
30	5000019	32	WASH\LOCK\3\8
31	5900160	1	COVER\CPLR\MTR
32	5900182	1	CNVYR\DGLG\2082\ASSY
33	5900183	1	SHFT\DRV\DGLG\2082\ASSY
34	5900186	1	CNVYR\DGLG\WELD
35	5900188	1	SHFT\IDL\DGLG\2082\ASSY
36	5900189	2	MNT\BRG\TNSN
37	5900190	1	BRKT\MTR\DGLG
38	5900191	1	SH\RAMP\MAG\DGLG
39	5900193	1	DOOR\DGLG
40	5900194	1	BELT\COVER\SHAFT\CNVYR
41	5900195	1	MNT\DGLG\CNVYR\CMF
42	5900196	1	CLMP\DGLG
43	5900197	1	GUIDE\CHAIN\FRNT\DGLG
44	5900198	1	GUIDE\CHAIN\REAR\DGLG
45	5900199	1	COVER\CHAIN\FRNT\DGLG
46	5900200	2	COVER\CHAIN\LEG\DGLG
47	5900201	1	PANEL\FRM\DGLG
48	5900202	1	SH\COVER\CHAIN\DGLG
49	5900203	1	MNT\TARP\FRM\
50	5900204	2	END\MNT\TARP
51	5900205	1	BELT\BACK\DGLG
52	5900210	1	SH\RAMP\L\DGLG
53	5900211	1	SH\RAMP\R\DGLG
54	5900212	2	BOLT\HINGE\BELT
55	7501271	2	MAG\PL\14X6X1-1\2

5900182

CNVYR\DGLG\2082\ASSY

MAGNETIC CONVEYOR CHUTE ASSEMBLY

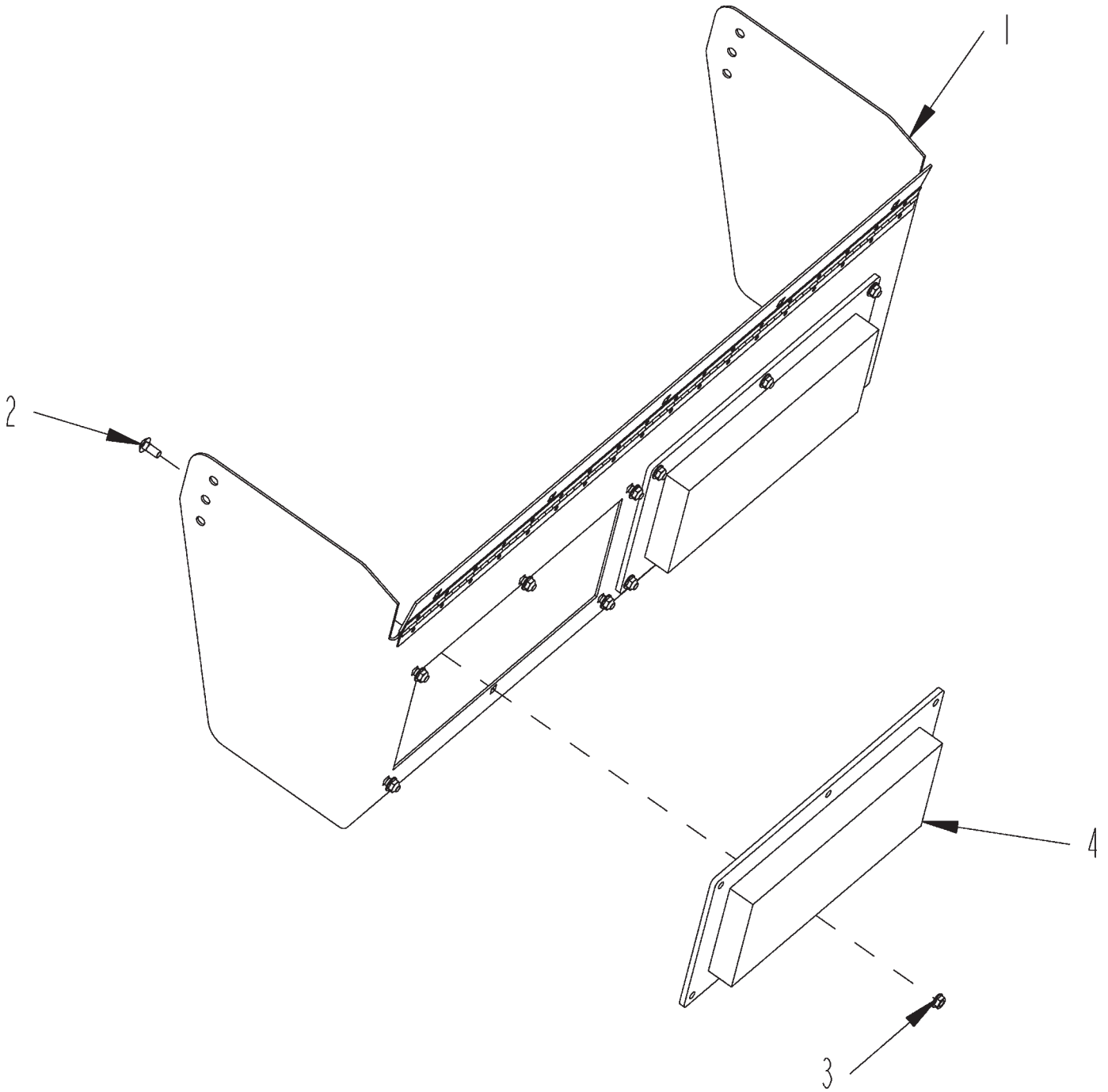

ITEM	PART NO.	QTY.	DESCRIPTION
1	4704357	1	CHUTE\MAG\CNVYR\WELD
2	4800153	12	BOLT\CRG\5/16X3/4\NC
3	4900108	12	NUT\FLG\SERR\5/16\NC
4	7501271	2	MAG\PL\14X6X1-1/2
	4704355		KIT\MAG\CNVYR\CMF

NON-MAGNETIC CONVEYOR CHUTE ASSEMBLY

ITEM	PART NO.	QTY.	DESCRIPTION
1	4704535	1	CHUTE\NON-MAG\CNVYR\WELD\EXTENSION CNVYR

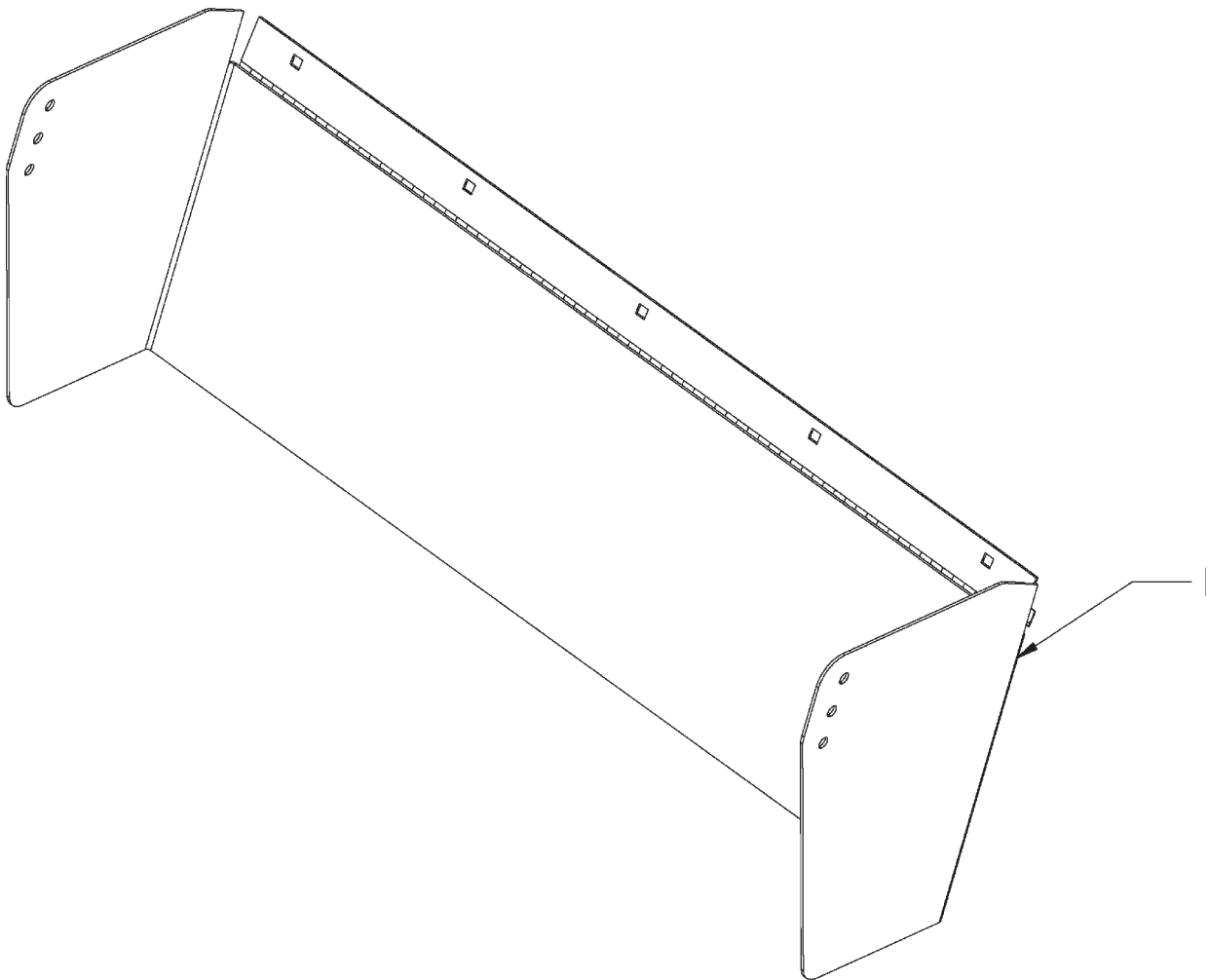

NON-MAGNETIC CONVEYOR END GATE ASSEMBLY

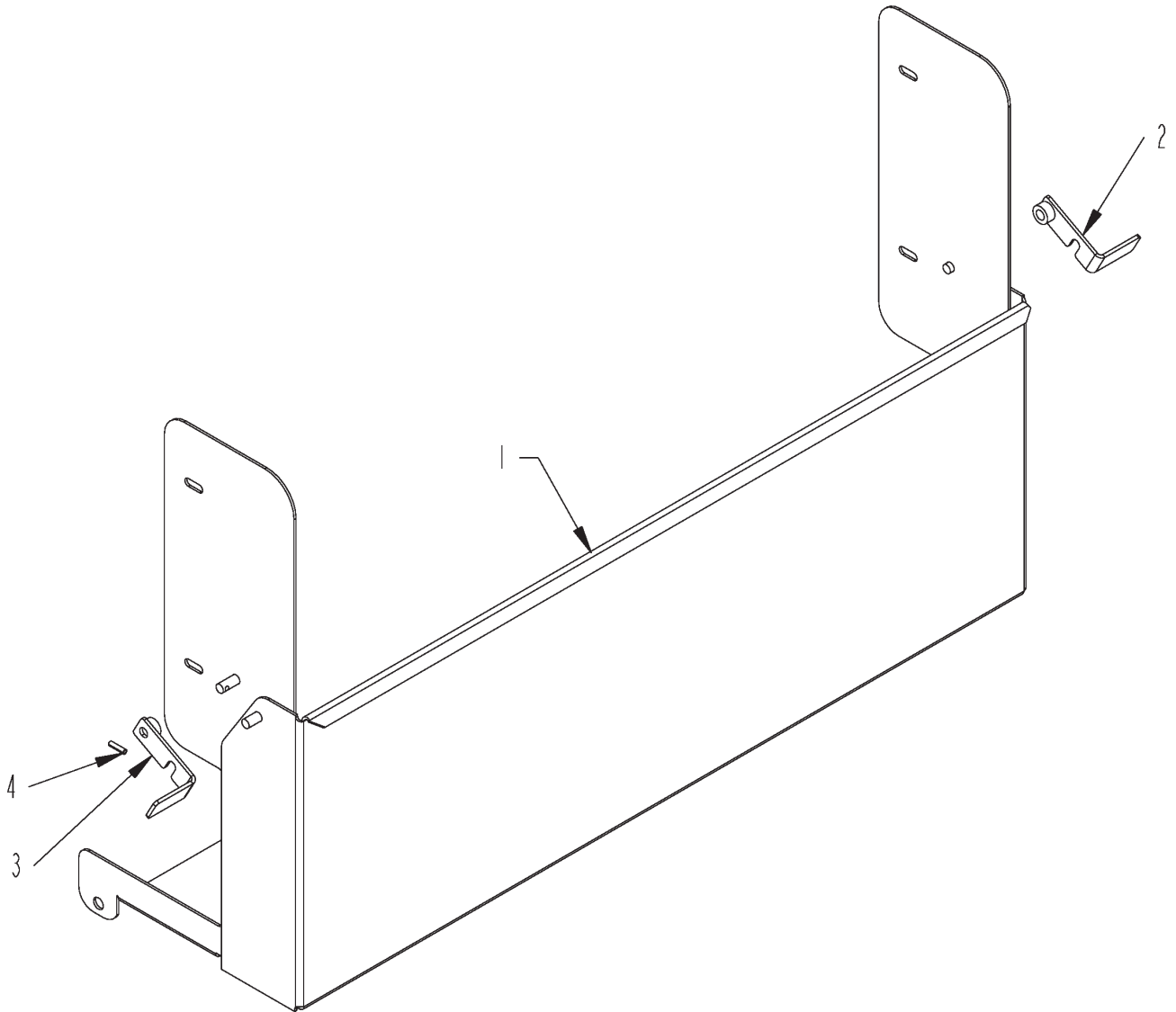

ITEM	PART NO.	QTY.	DESCRIPTION
1	4704563	1	GATE\END\CNVYR
2	4704594	1	LATCH\GATE\END\CNVYR\L
3	4704595	1	LATCH\GATE\END\CNVYR\R
4	4800313	2	PIN\RLLD\3/16X3/4
	4704593		GATE\END\CNVYR\ASSY

MAGNETIC CONVEYOR END GATE ASSEMBLY

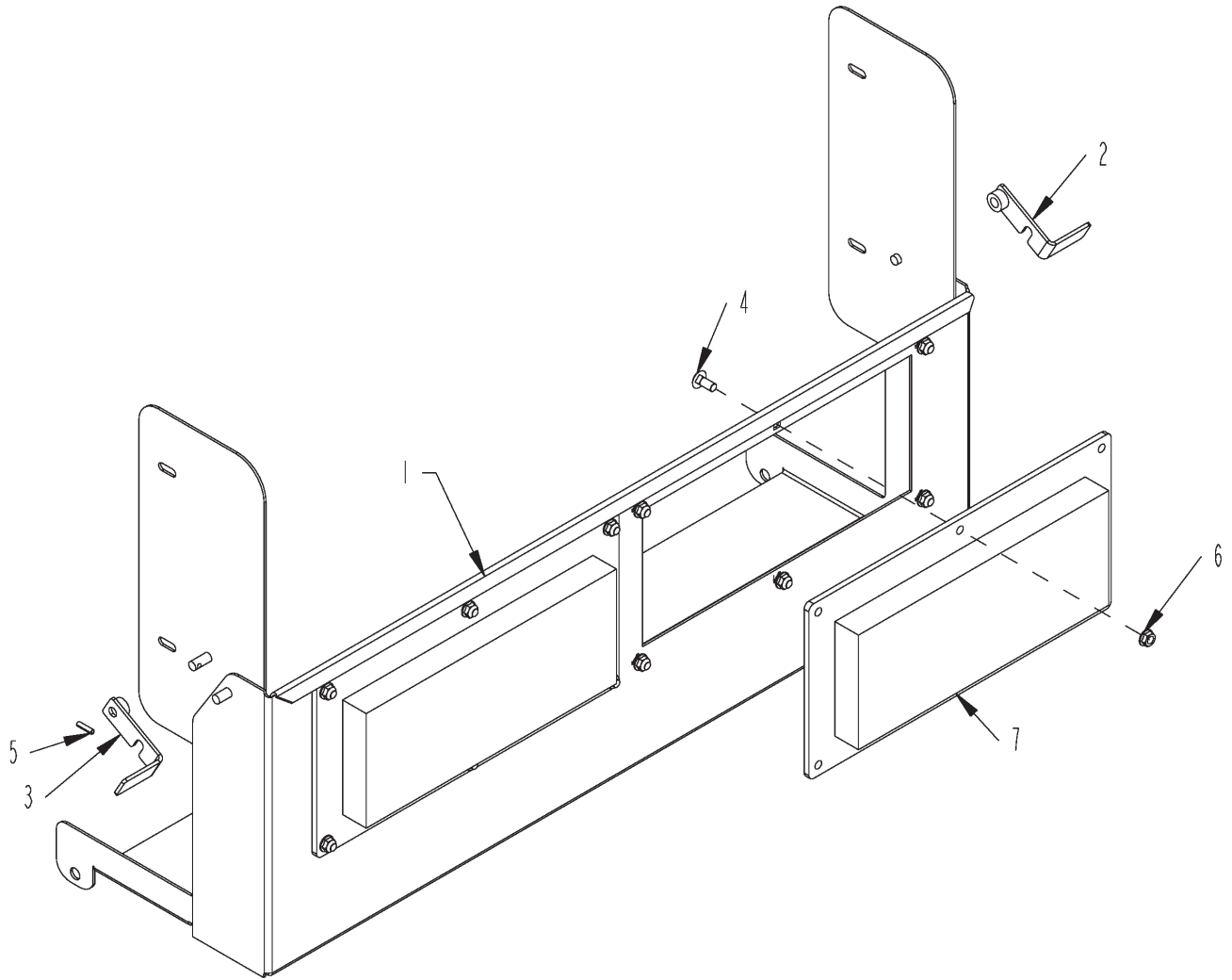

ITEM	PART NO.	QTY.	DESCRIPTION
1	4704565	1	MAG\END\GATE\CNVYR
2	4704594	1	LATCH\GATE\END\CNVYR\L
3	4704595	1	LATCH\GATE\END\CNVYR\R
4	4800153	12	BOLT\CRG\5\16X3\4\NC
5	4800313	2	PIN\RLLD\3\16X3\4
6	4900108	12	NUT\FLG\SERR\5\16\NC
7	7501271	2	MAG\PL\14X6X1-1\2
	4704566		GATE\END\MAG\CNVYR\ASSY

HYDRAULIC TANK ASSEMBLY

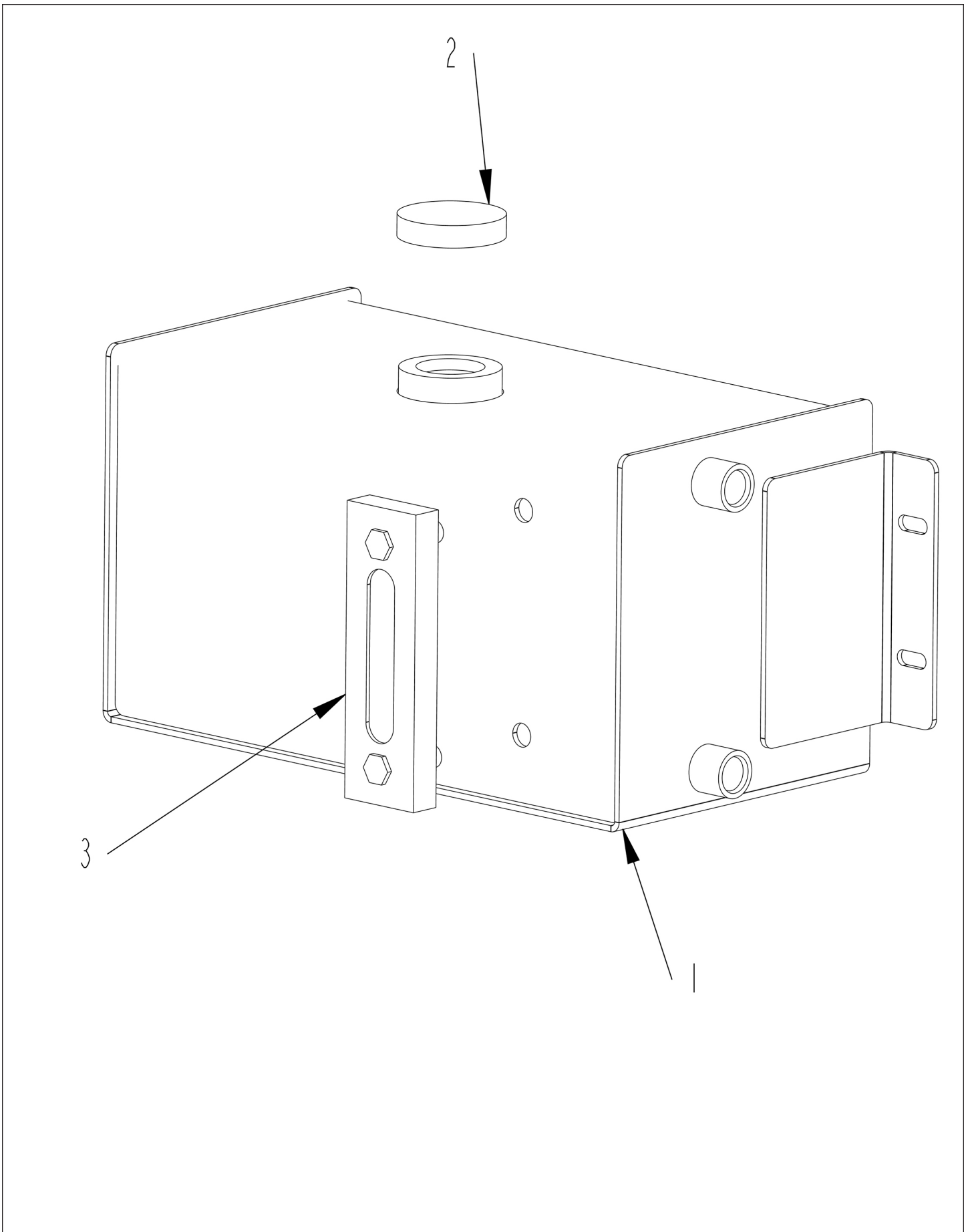

HYDRAULIC TANK ASSEMBLY

ITEM	PART	QTY.	PART DESCRIPTION
1	4704505	1	TANK\HYD\WELD\CMF
2	7500275	1	CAP\VENTED\TANK\OIL
3	7501242	1	GAUGE\LEVEL\5\M12\NOTHERMOMETER
	4504506		TANK\HYD\ASSY\CMF

SINGLE DISCHARGE CONVEYOR HYDRAULICS

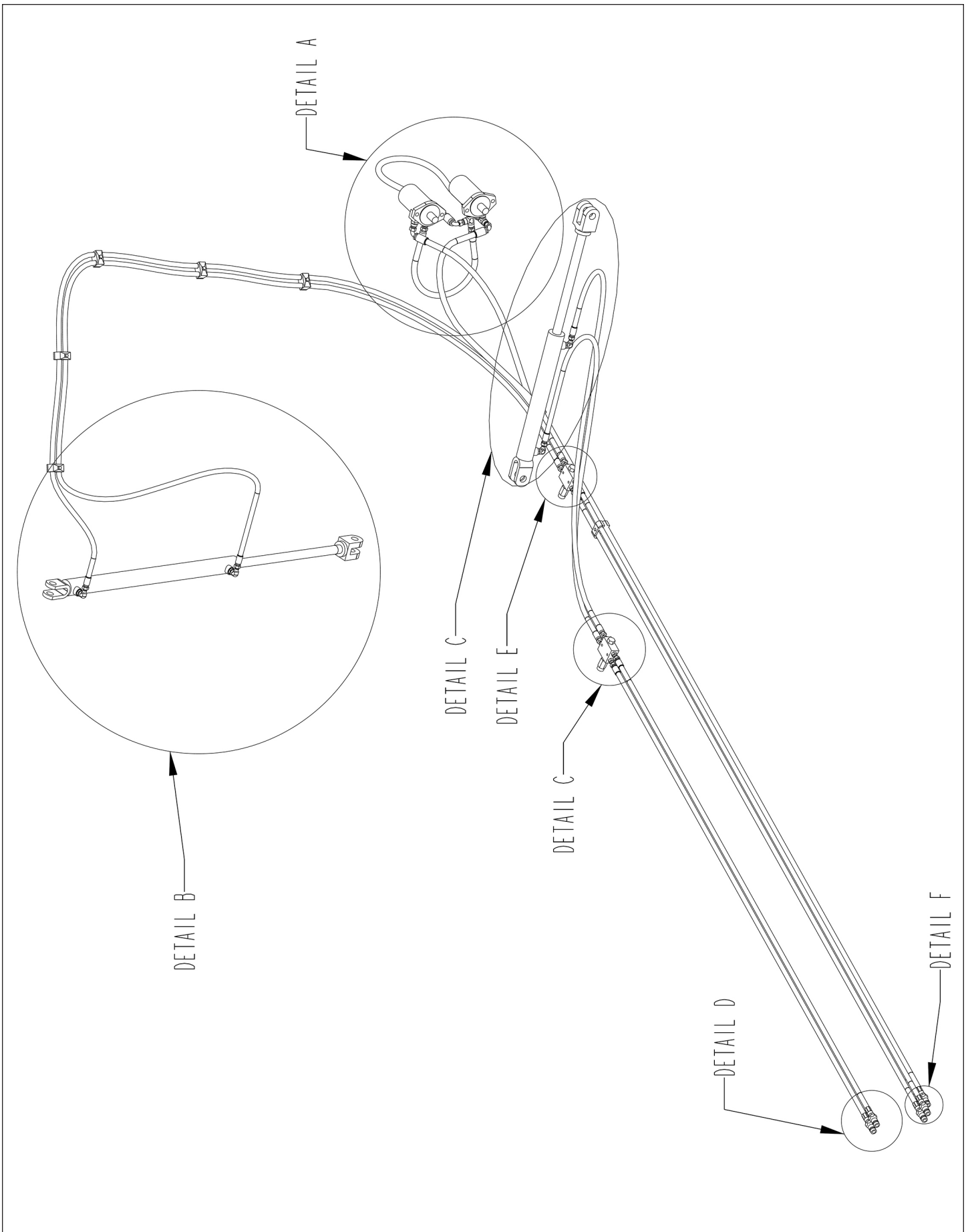

SINGLE DISCHARGE CONVEYOR HYDRAULICS - DETAIL A

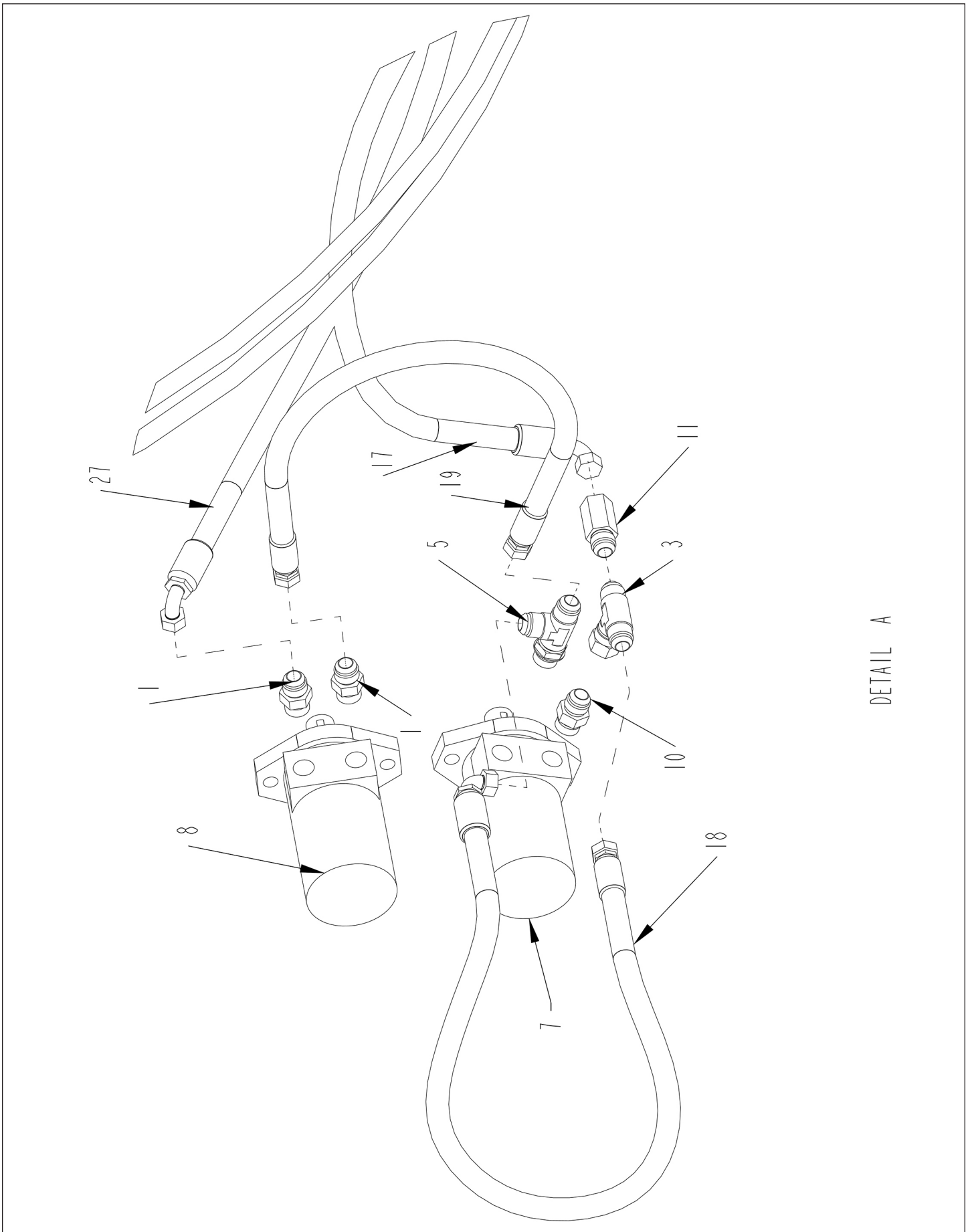

DETAIL A

SINGLE DISCHARGE CONVEYOR HYDRAULICS - DETAIL B

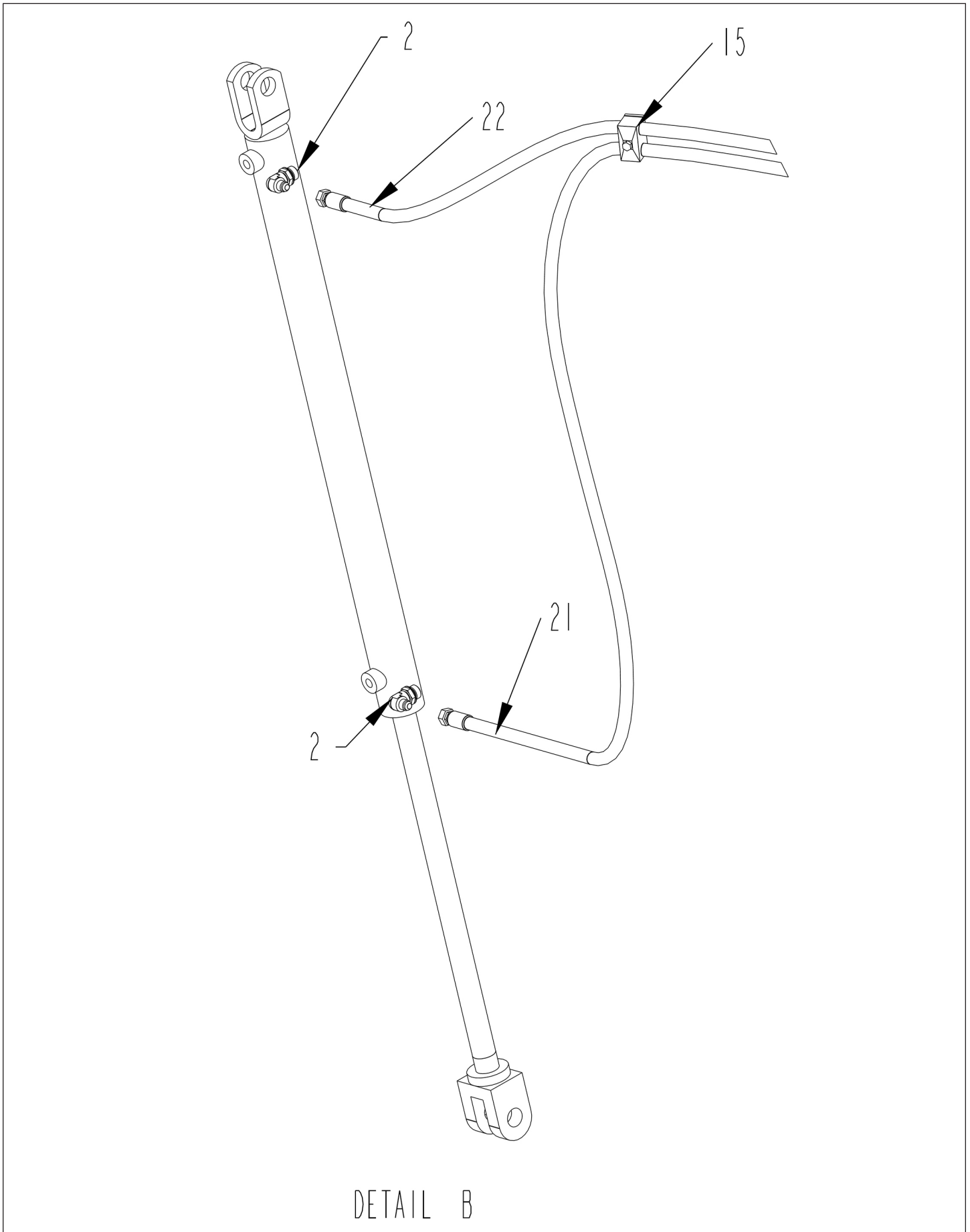

DETAIL B

SINGLE DISCHARGE CONVEYOR HYDRAULICS - DETAILS C AND D

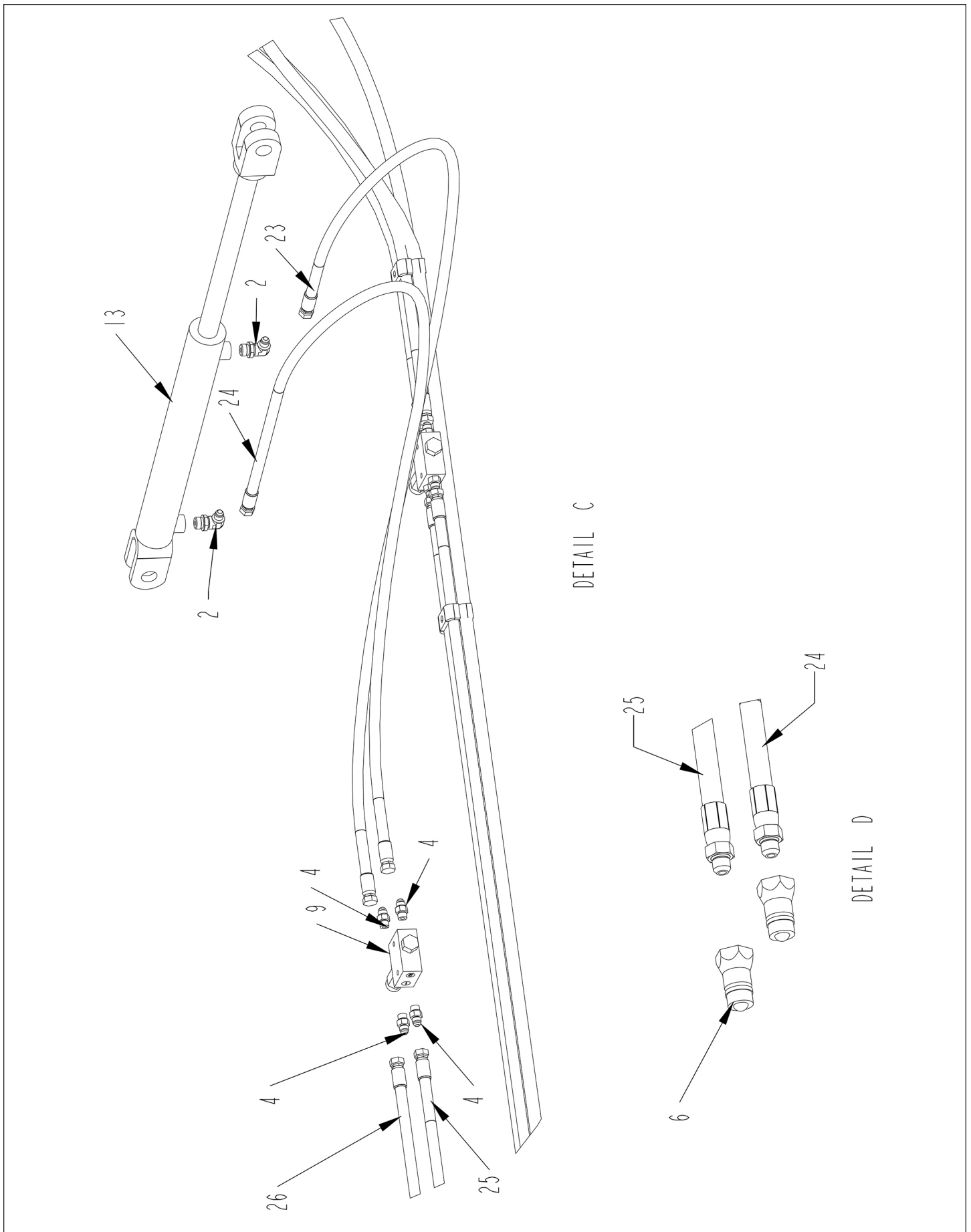

DETAIL C

DETAIL D

SINGLE DISCHARGE CONVEYOR HYDRAULICS - DETAILS E AND F

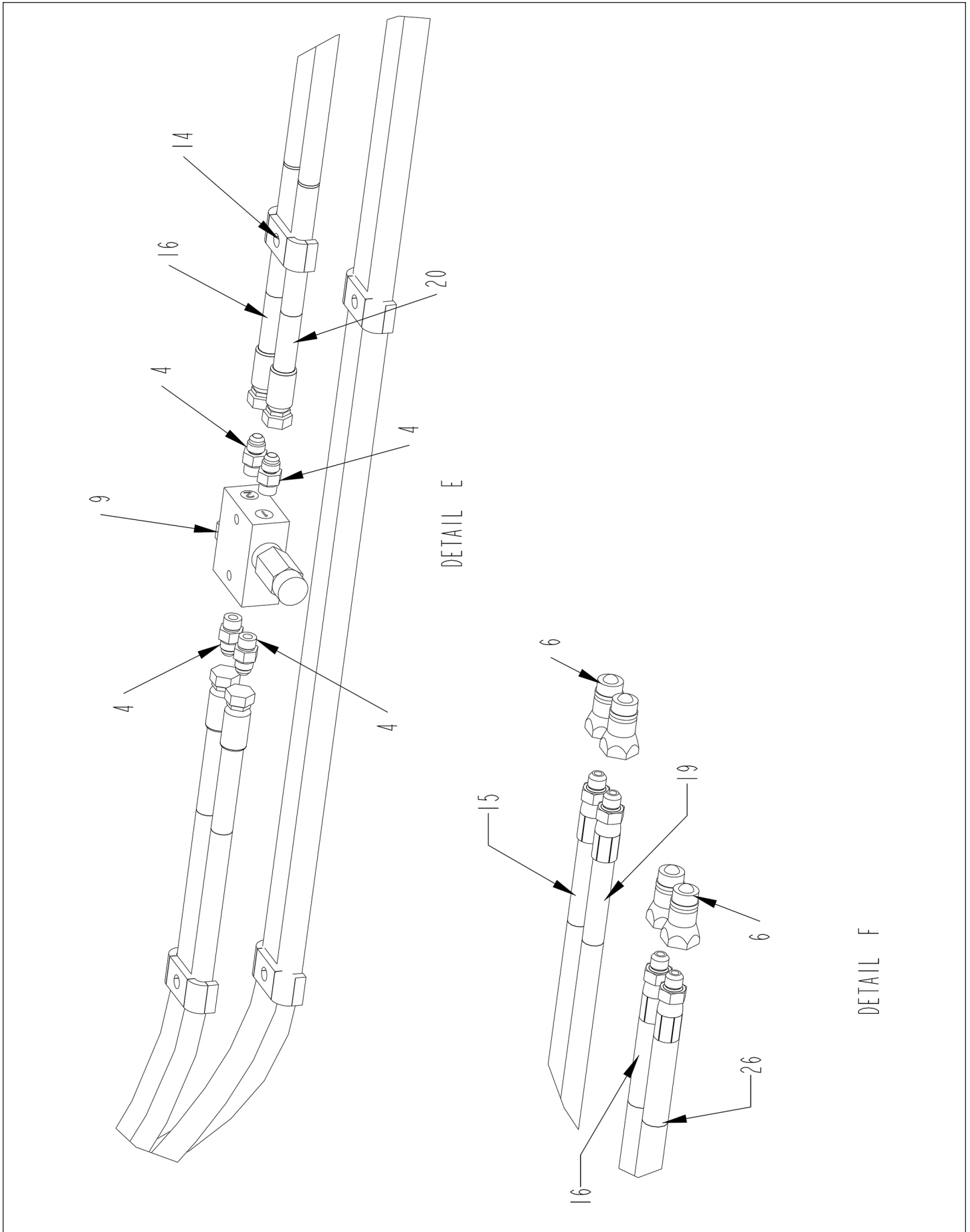

SINGLE DISCHARGE CONVEYOR HYDRAULICS

ITEM	PART	QTY.	PART DESCRIPTION
1	3800448	2	FTG\7/8MORX7/8MJIC\ST
2	3800453	4	FTG\3/4MORX9/16MJIC\90
3	3800461	1	FTG\7/8MJIC7/8MJIC7/8FJICS\BR;TEE
4	3800631	8	FTG\9/16MORX9/16MJIC\ST
5	3800686	1	MORMJICMJIC
6	3800694	6	FTG\3/4FOR\QUICK;CPLR\MALE
7	3900025	1	MOTOR\HYD\17.9\H
8	3900032	1	MOTOR\HYD\22.6\H
9	4000245	2	VALVE\RELIEF\CROSS\SINGLE
10	4000288	1	FTG\7/8MORX7/8MJIC\ST\CHCK
11	4000293	1	VALVE\CHECK\7/8FJICX7/8MJIC
12	4100247	1	CYL\HYD\2X30\1-1/8_ROD
13	4100284	1	CYL\HYD\2X16\1-1/4RD\WELDE
14	4700776	4	CLMP\HOSE\3/8
15	7501336	5	CLMP\HOSE\CUSH\3/8
16	3701491	1	HOSE\HYD\3/8X129\9/16FJICX3/4MOR PRESSURE RELIEF VALVE TO TRACTOR COUPLER
17	3701496	1	HOSE\HYD\1/2X194\7/8MORX3/4FJICS BOTTOM EXTENSION CHAIN MOTOR TO TRACTOR COUPLER
18	3700810	1	HOSE\HYD\1/2X18\7/8FJIC90X7/8FJIC TOP EXTENSION MOTOR TEE TO BOTTOM EXTENSION CHECK VALVE/TEE
19	3700811	1	HOSE\HYD\1/2X34\7/8FJICX7/8FJIC BOTTOM MAIN CHAIN MOTOR TO TOP EXTENSION MOTOR TEE
20	3701491	1	HOSE\HYD\3/8X129\9/16FJICX3/4MOR PRESSURE RELIEF VALVE TO TRACTOR COUPLER
21	3701492	1	HOSE\HYD\3/8X173\9/16FJICS PRESSURE RELIEF VALVE TO ROD END DOOR CYLINDER
22	3701493	1	HOSE\HYD\3/8X153\9/16FJICS PRESSURE RELIEF VALVE TO TUBE END DOOR CYLINDER
23	3701494	1	HOSE\HYD\3/8X65\9/16FJICS PRESSURE RELIEF VALVE TO ROD END CONVEYOR CYLINDER
24	3701362	1	HOSE\HYD\3/8X48\9/16FJIC PRESSURE RELIEF VALVE TO TUBE END CONVEYOR CYLINDER
25	3701495	1	HOSE\HYD\3/8X95\9/16FJIC PRESSURE RELIEF VALVE TO TRACTOR COUPLER
26	3701495	1	HOSE\HYD\3/8X95\9/16FJIC PRESSURE RELIEF VALVE TO TRACTOR COUPLER
27	3701496	1	HOSE\HYD\1/2X194\7/8MORX3/4FJICS TOP MAIN CHAIN MOTOR TO TRACTOR COUPLER

GEARBOX HYDRAULIC SCHEMATIC

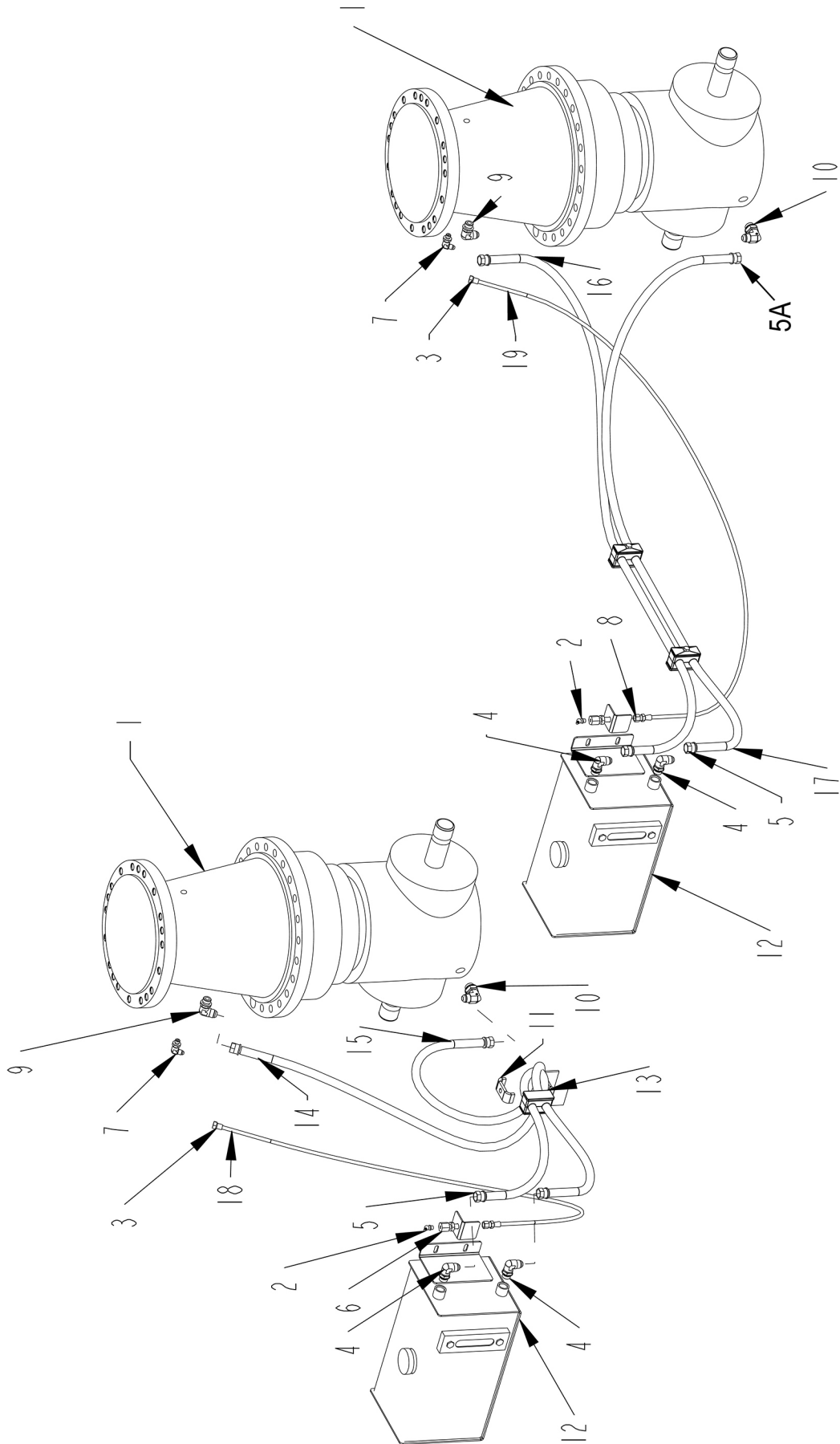

GEARBOX HYDRAULIC SCHEMATIC

ITEM	PART	QTY.	PART DESCRIPTION
1	3100226	2	GRBX\PLANETARY\DBL\2100
2	3800135	2	FTG\LUB\1/8MPXZRK\SHORT
3	3800514	2	FTG\1/4MPX1/8FP\ADPT
4	3800537	4	FTG\3/4MORX3/4MJIC\90
5	3800826	6	FTG\3/4FJICX1/2SHLCK
5A	3800864	2	FTG\7/8FJICX1/2PSHLCK
6	3800861	2	FTG\7/8MJICX1/2FP\BULKHEAD
7	3800862	2	FTG\7/16MJICX#4BSPP
8	3800865	2	FTG\7/16FJICX1/8BARB\HEWFERRULE
9	3800960	2	FTG\3/4MJICX3/8BSPP\90
10	3800863	2	FTG\7/8MJICX#10BSPP
11	4700776	1	CLMP\HOSE\3/8
12	4704506	2	TANK\HYD\ASSY\CMF
13	7501525	3	CLAMP\HOSE\1/2\2
14	3701614	1	HOSE\LUB\1/2X92 FRONT TANK TOP PORT TO TOP PORT FRONT GEARBOX
15	3701615	1	HOSE\LUB\1/2X65 FRONT TANK BOTTOM PORT TO BOTTOM PORT FRONT GEARBOX
16	3701616	1	HOSE\LUB\1/2X70 REAR TANK TOP PORT TO TOP PORT REAR GEARBOX
17	3701616	1	HOSE\LUB\1/2X70 REAR TANK BOTTOM PORT TO BOTTOM PORT REAR GEARBOX
18	3701576	1	HOSE\GRS\1/8X95 GREASE PORT TO ZERK BULKHEAD
19	3701577	1	HOSE\GRS\1/8X73 GREASE PORT TO ZERK BULKHEAD
	3701557		HOSE\KIT\LUBE\CMF710

OPTIONAL DOGLEG CONVEYOR HYDRAULIC SCHEMATIC

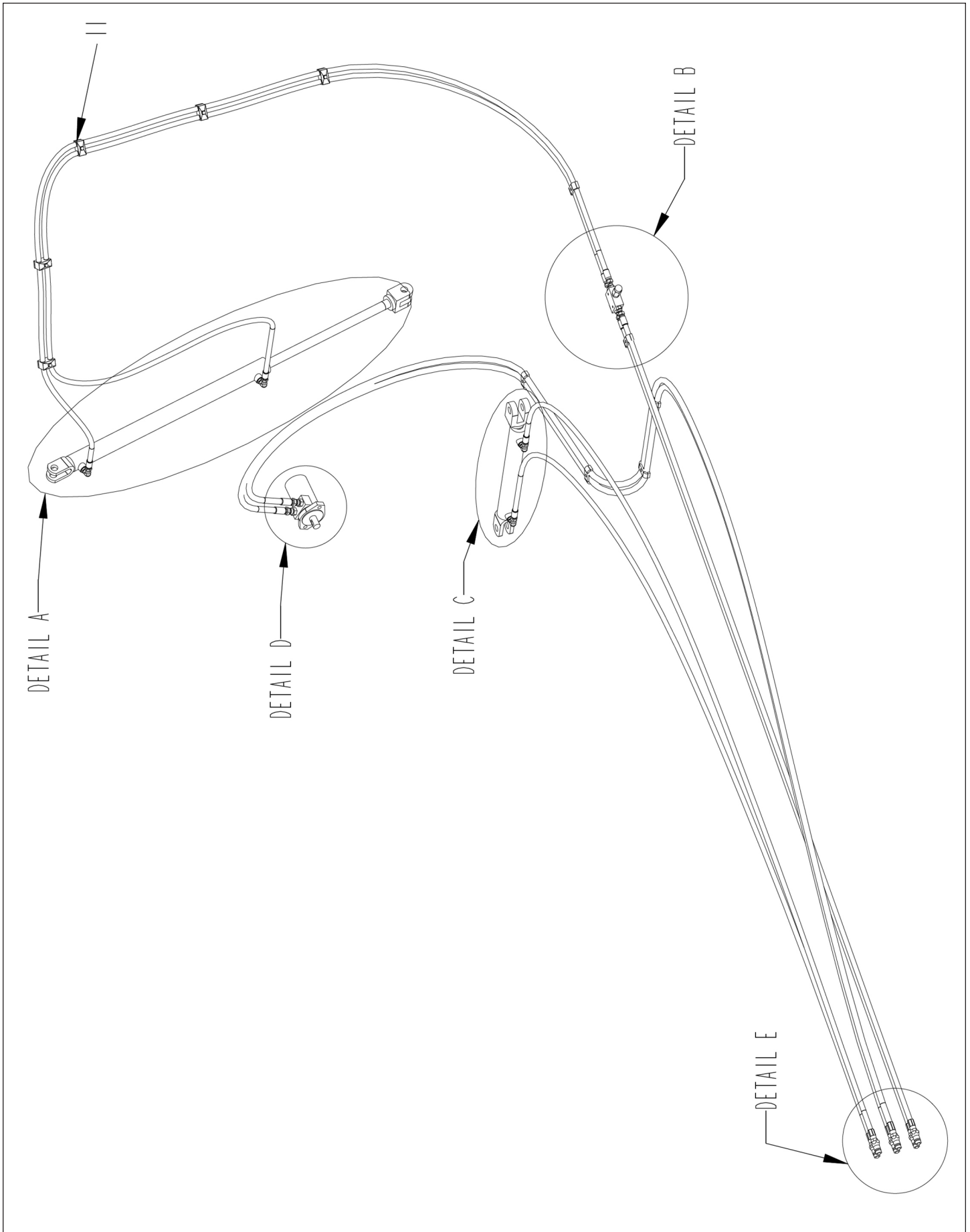

OPTIONAL DOGLEG CONVEYOR HYDRAULIC SCHEMATIC - DETAIL A

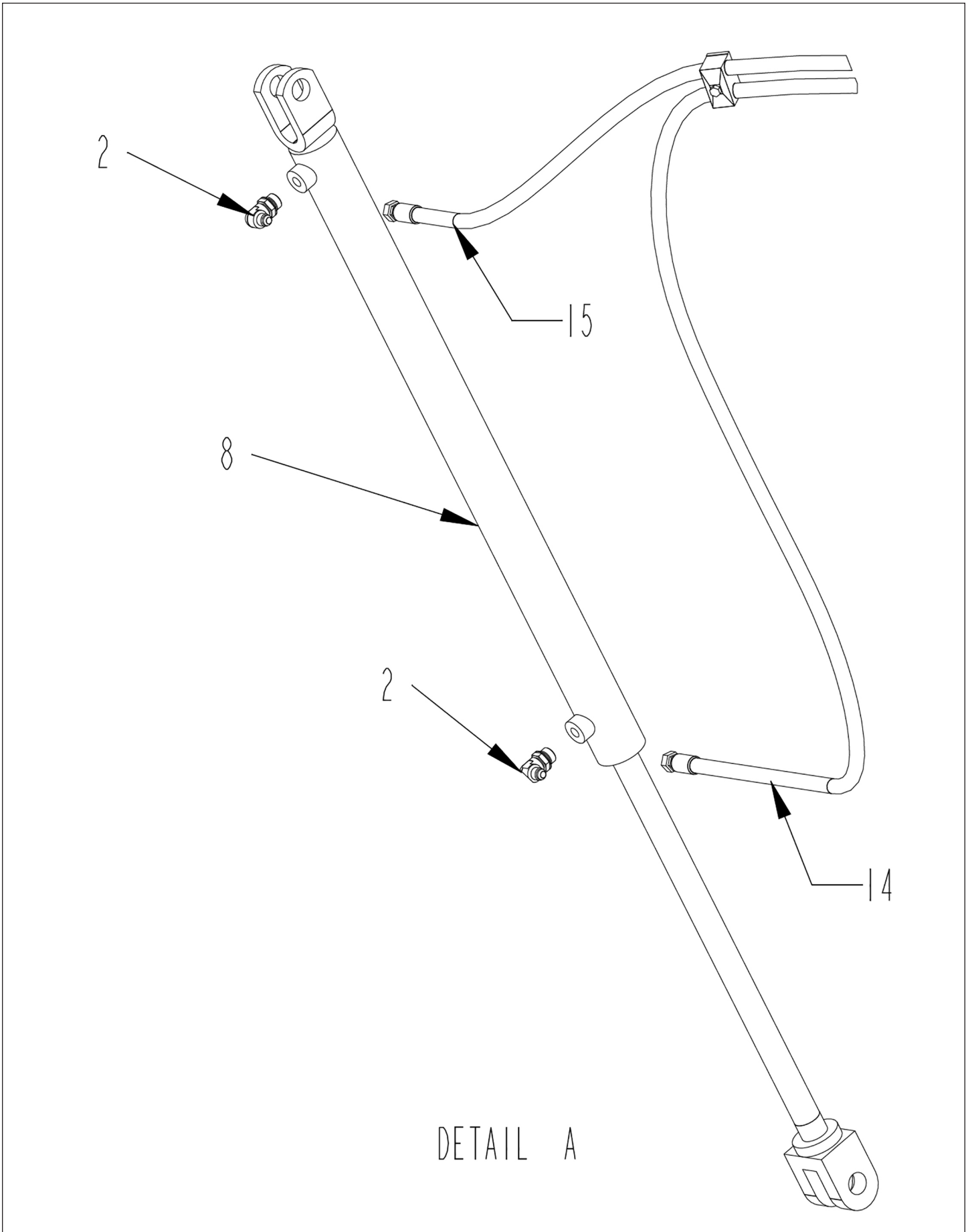

DETAIL A

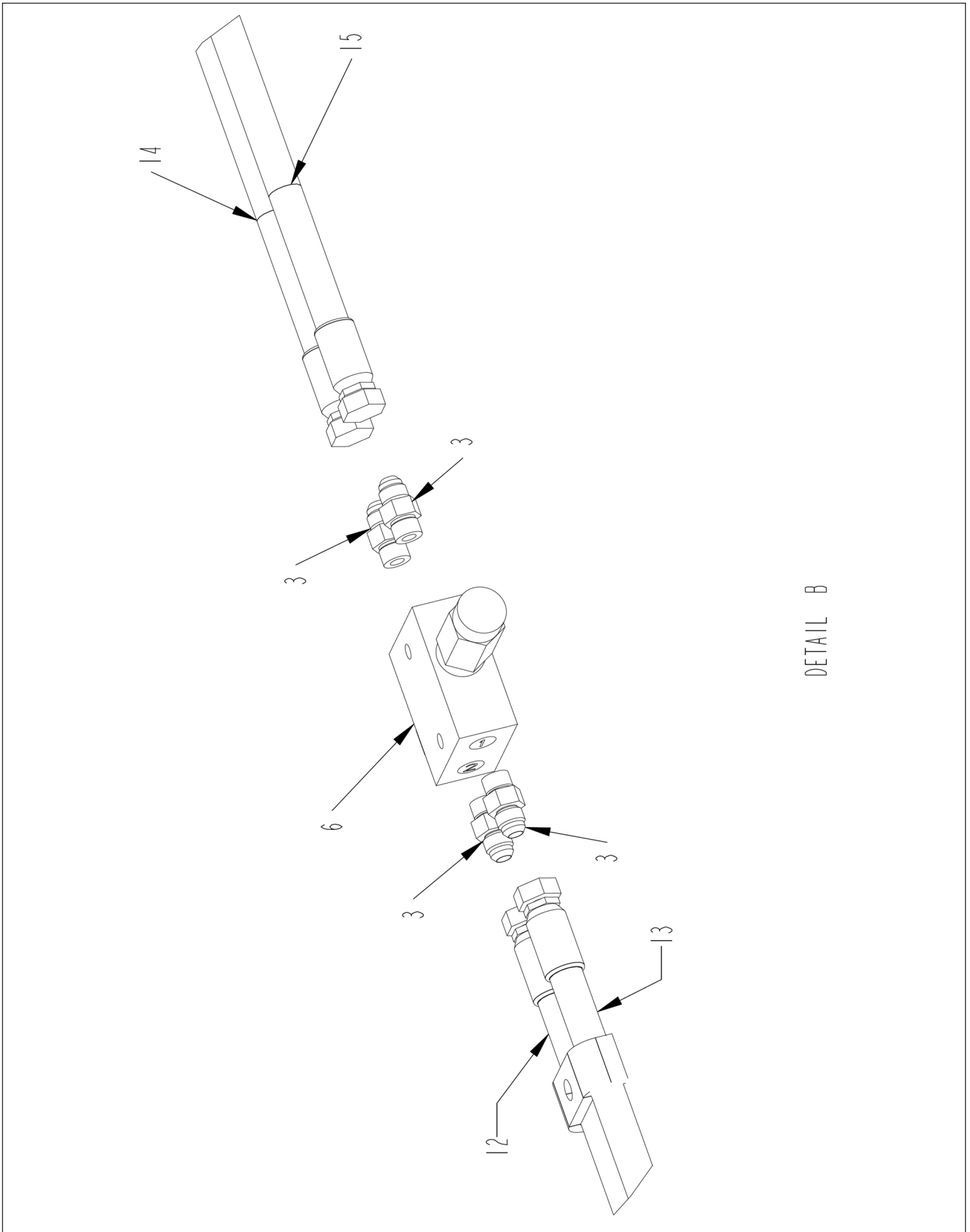

DETAIL B

OPTIONAL DOGLEG CONVEYOR HYDRAULIC SCHEMATIC - DETAILS C AND D

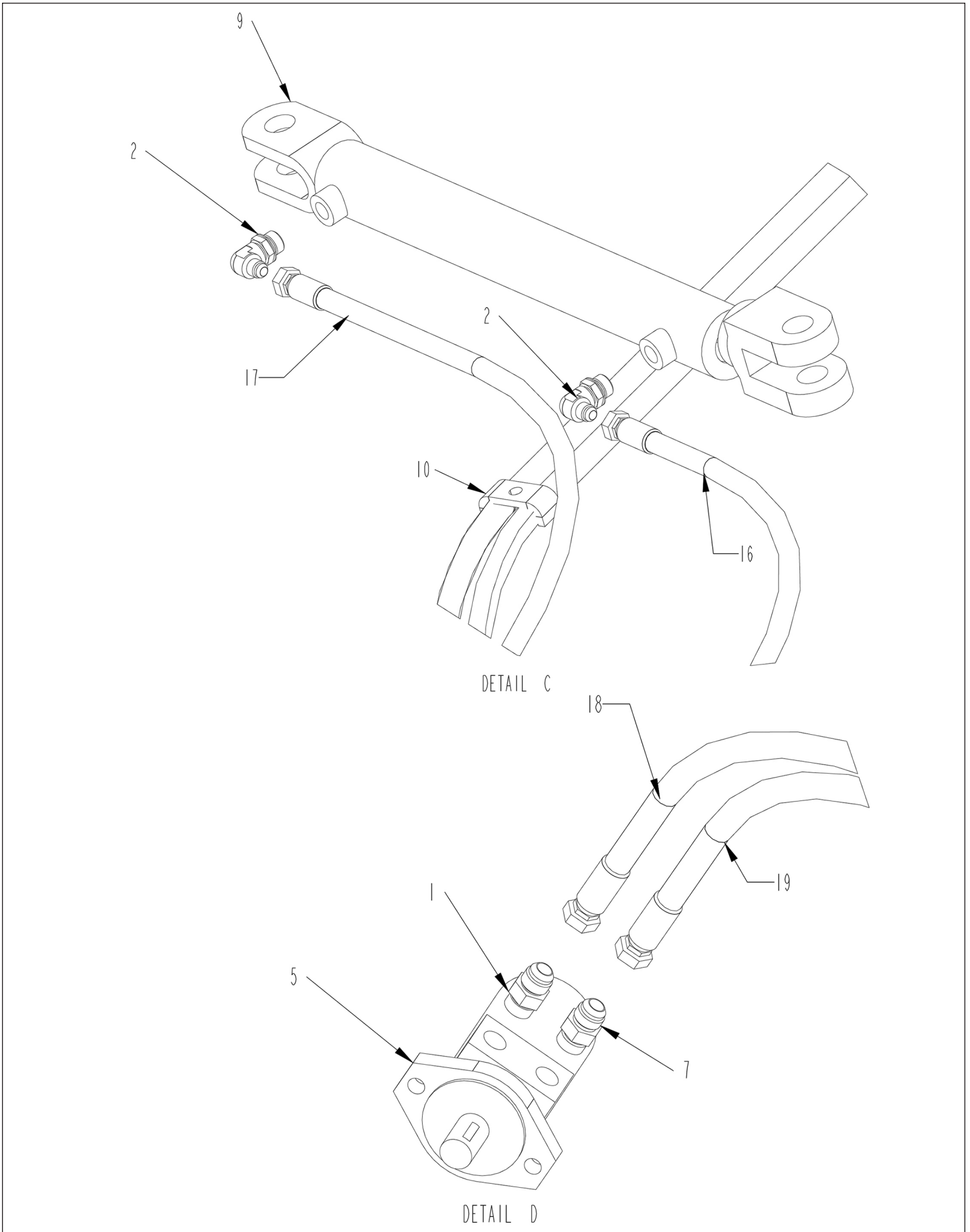

OPTIONAL DOGLEG CONVEYOR HYDRAULIC SCHEMATIC - DETAIL E

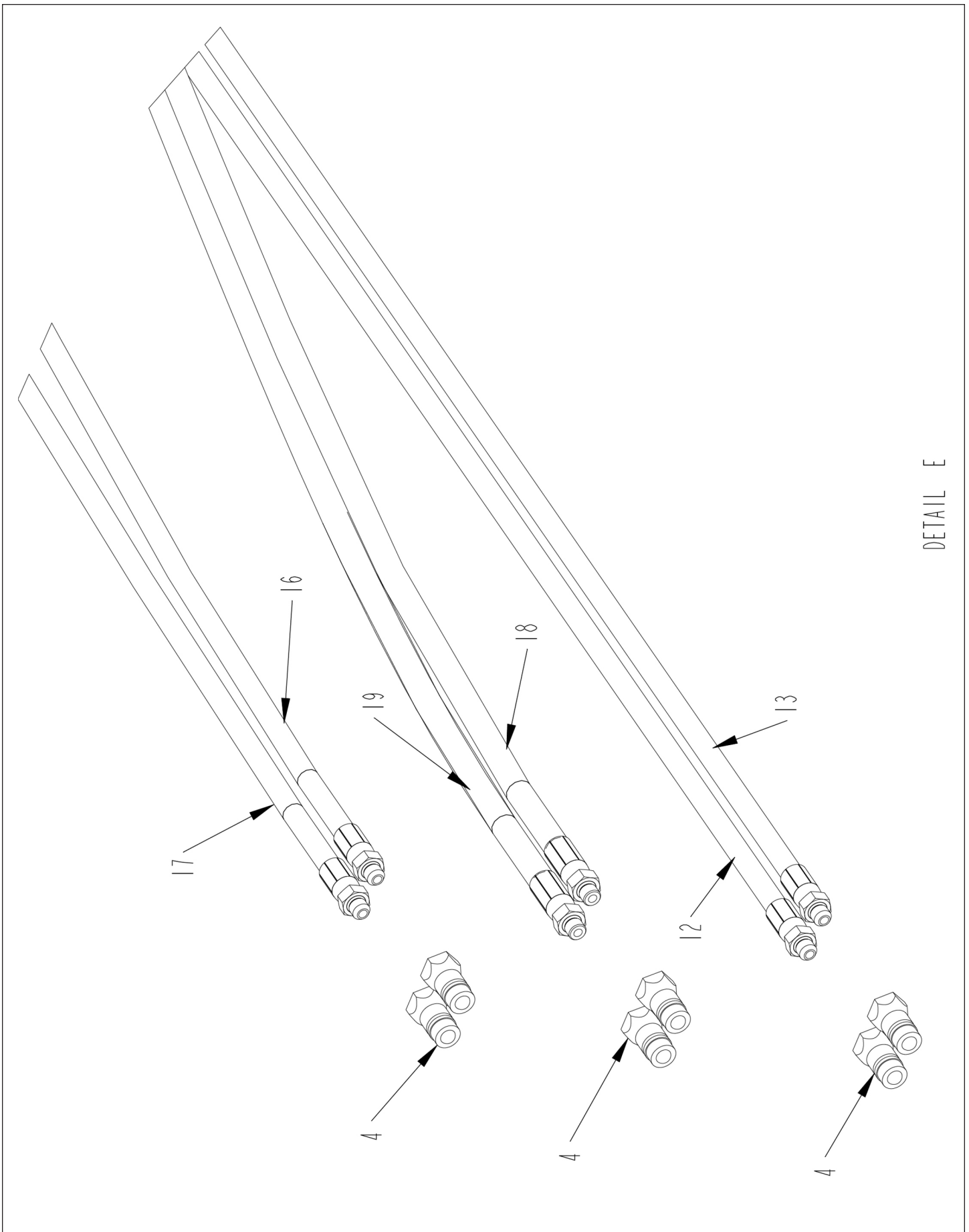

OPTIONAL DOGLEG CONVEYOR HYDRAULIC SCHEMATIC

ITEM	PART	QTY.	PART DESCRIPTION
1	3800448	1	FTG\7/8MORX7/8MJIC\ST
2	3800453	4	FTG\3/4MORX9/16MJIC\90
3	3800631	4	FTG\9/16MORX9/16MJIC\ST
4	3800694	6	FTG\3/4FOR\QUICK;CPLR\MALE
5	3900032	1	MOTOR\HYD\22.6\H
6	4000245	1	VALVE\RELIEF\CROSS\SINGLE
7	4000288	1	FTG\7/8MORX7/8MJIC\ST\CHCK
8	4100247	1	CYL\HYD\2X30\1-1/8_ROD
9	4100284	1	CYL\HYD\2X16\1-1/4RD\WELDE
10	4700776	6	CLMP\HOSE\3/8
11	7501336	5	CLMP\HOSE\CUSH\3/8
12	3701491	1	HOSE\HYD\3/8X129\9/16FJICX3/4MOR PRESSURE VALVE TO TRACTOR COUPLER
13	3701491	1	HOSE\HYD\3/8X129\9/16FJICX3/4MOR PRESSURE VALVE TO TRACTOR COUPLER
14	3701492	1	HOSE\HYD\3/8X173\9/16FJICS PRESSURE VALVE TO ROD END DOOR CYLINDER
15	3701493	1	HOSE\HYD\3/8X153\9/16FJICS PRESSURE VALVE TO TUBE END DOOR CYLINDER
16	3701497	1	HOSE\HYD\3/8X155\9/16FJICS ROD END CONVEYOR CYLINDER TO TRACTOR COUPLER
17	3701498	1	HOSE\HYD\3/8X135\9/16FJIC TUBE END CONVEYOR CYLINDER TO TRACTOR COUPLER
18	3701499	1	HOSE\HYD\1/2X235\7/8MORX3/4FJICS TOP PORT CHAIN MOTOR TO TRACTOR COUPLER
19	3701499	1	HOSE\HYD\1/2X235\7/8MORX3/4FJICS BOTTOM PORT CHAIN MOTOR COUPLER

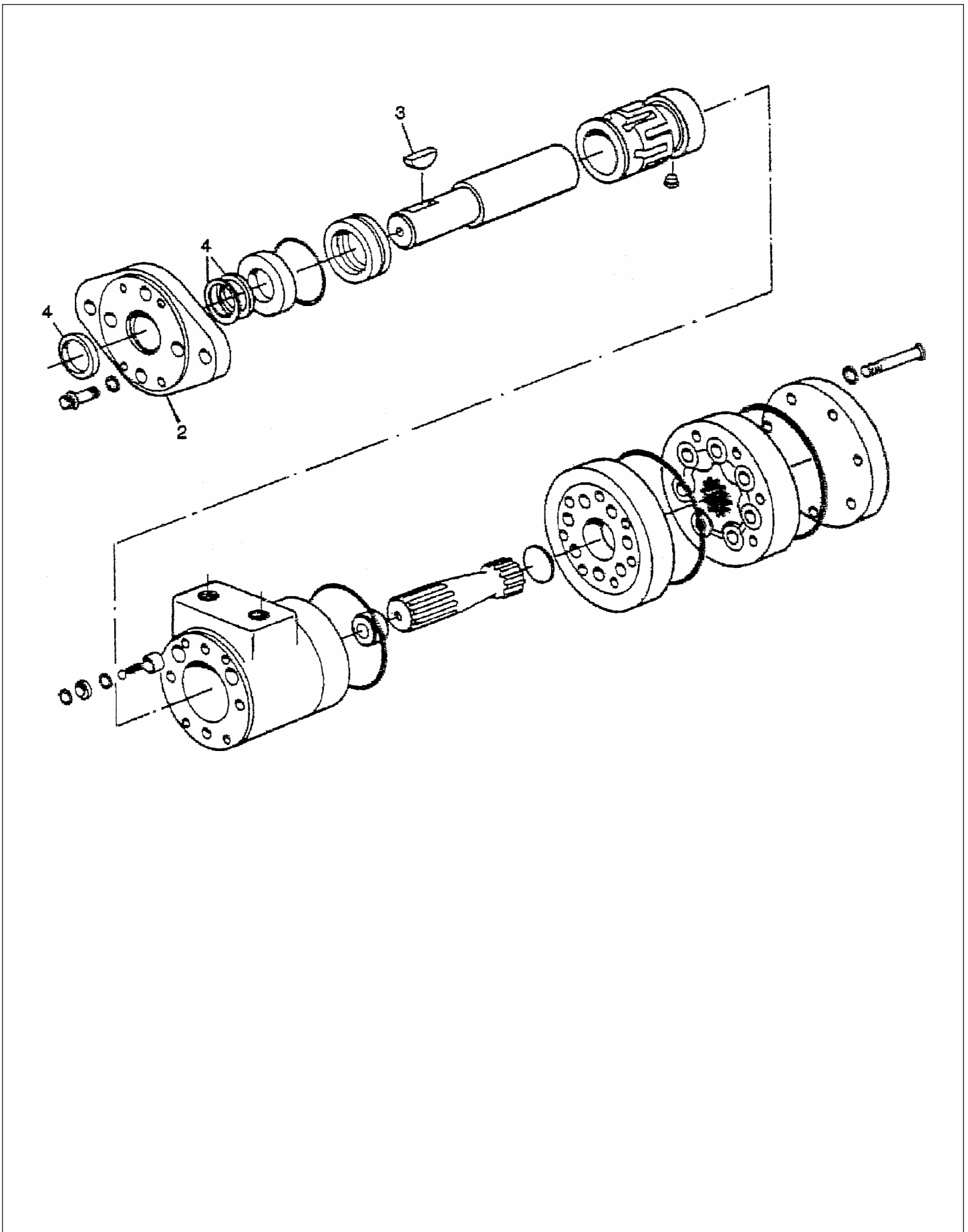

ORBIT MOTORS 3900025-3900032

ITEM	PART	QTY.	PART DESCRIPTION
1	3900025		MTR\HYD\17.9\HA;MNT\7\8FOR O-RING THREAD
	3900032		MTR\HYD\101-1040\22.6CI O-RING
2	3900002	1	MOUNTING FLANGE
3	6200011	1	KEY\WDF\1\4X1\#15\808
4	7501038	1	UNISEAL KIT 007-009

HYDRAULIC CYLINDER ASSEMBLY

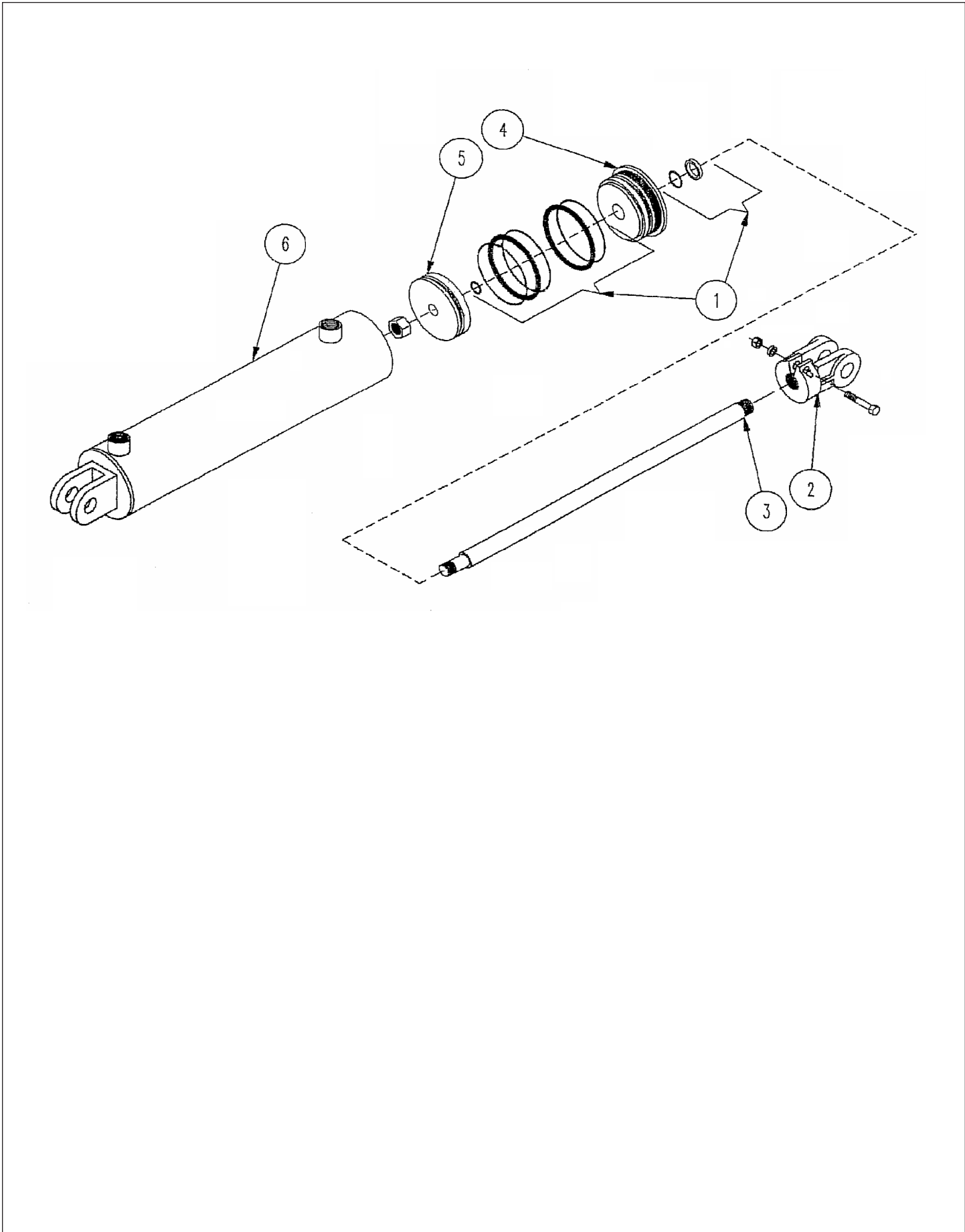

HYDRAULIC CYLINDER ASSEMBLY

ITEM	PART	QTY.	PART DESCRIPTION
	4100284		CYL\HYD\2X16\1-1/4ROD\WLD
1	4100241		CYL\HYD\2X24\1-1/4RD\3000PSI
	4100228		SEAL\KIT\2\1-1/4RD\CTD

3100225 - 2-SPEED GEARBOX ASSEMBLY

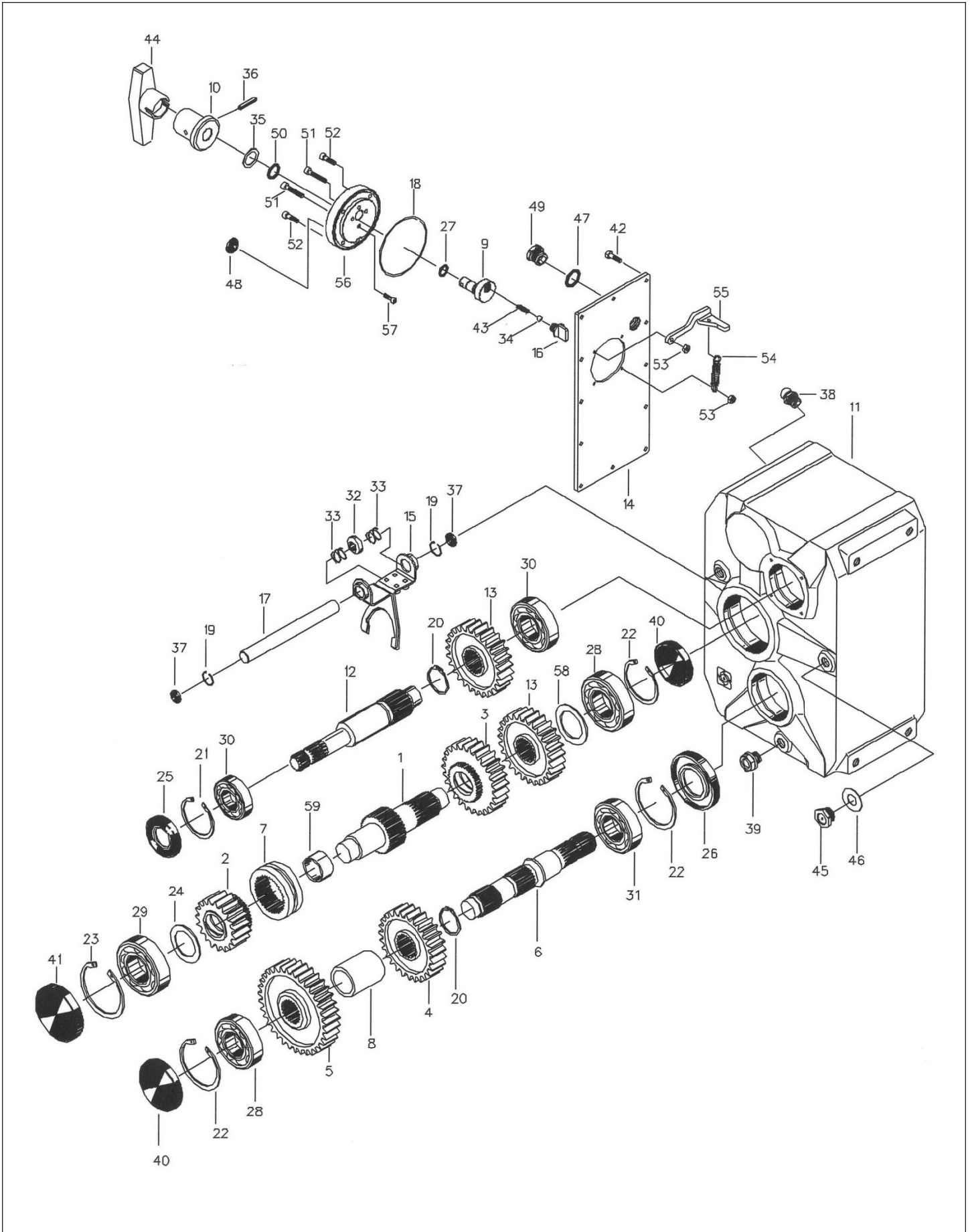

3100225 - 2-SPEED GEARBOX ASSEMBLY

ITEM	PART	QTY.	PART DESCRIPTION
	3100225		GRBX\2SPD\1.84:1\B&P6078
18	3100412	1	ORING\STD\3375
25	3100413	1	SEAL\OIL\B&P\45X85X10
26	3100414	1	SEAL\OIL\B&P\50X90X10
27	3100415	1	ORING\STD\3043
38	3100416	1	PLUG\BRTHR\B&P\1/2
40	3100417	2	PLUG\OIL\B&P\RCA90
41	3100418	1	PLUG\OIL\B&P\RCA110
45	3100419	1	PLUG\OIL\B&P\1/2
46	3100420	1	SLEEVE\B&P\215X268X15
47	3100421	1	ORING\STD\3100
51	3100422	1	SEAL\OIL\B&P\16X22X34



3100226 - PLANETARY GEARBOX ASSEMBLY

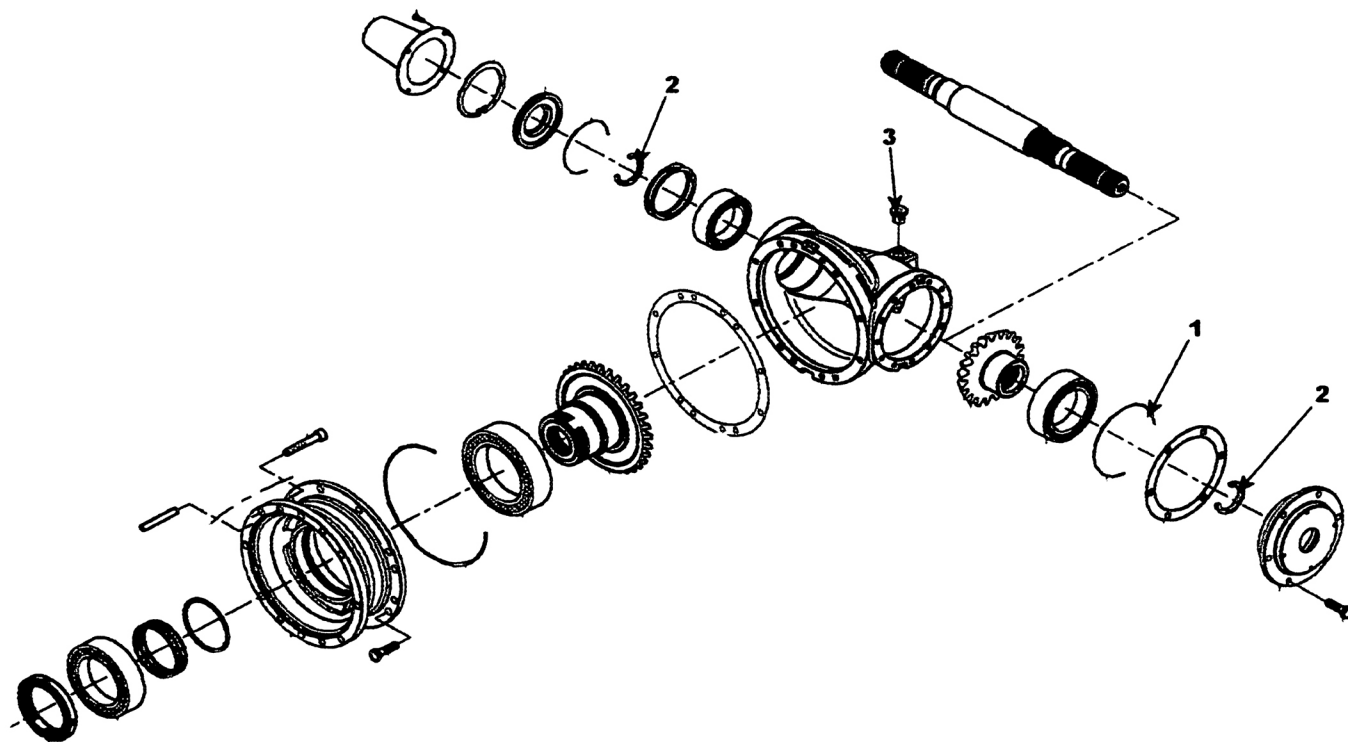

ITEM	PART #	QTY	DESCRIPTION
1	3100395	1	SEAL\OIL\INPUT\KIT\RR1800
2	3100396	2	ORING\COVER\INPUT\RR1800
3	3100425	2	PLUG\MAG\1/2BSPP\GRBX\CMF

NOT SHOWN
3100432 SEAL\KIT\GRBX\2100RR

HUB ASSEMBLY

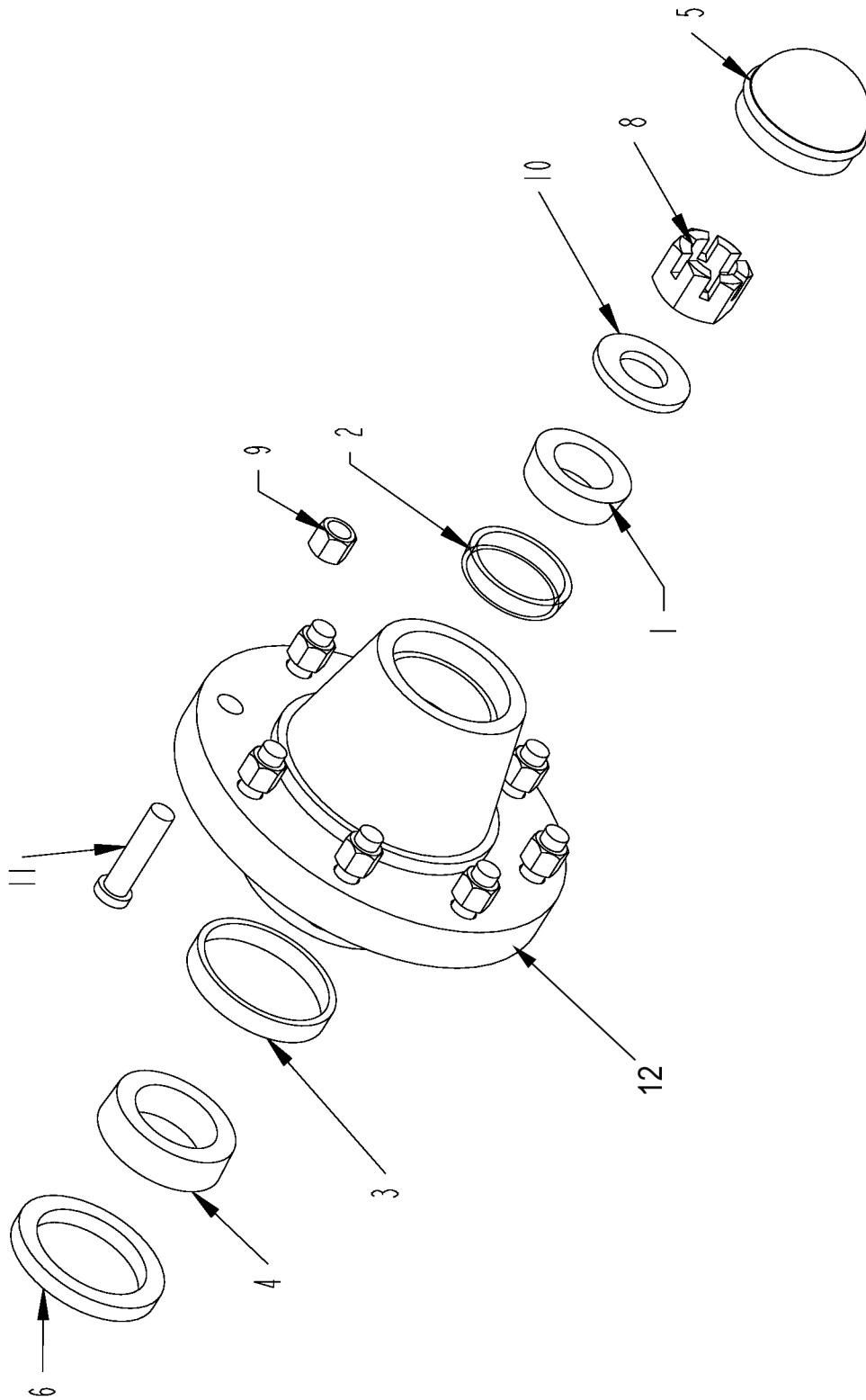

HUB ASSEMBLY

ITEM	PART	QTY.	PART DESCRIPTION
1	2900125	1	HUB\H817\CONE\OUTER (LM501349)
2	2900126	1	HUB\H817\CUP\OUTER (LM501310)
3	2900127	1	HUB\H817\CUP\INNER (382A)
4	2900128	1	HUB\H817\CONE\INNER (387A)
5	2900130	1	CAP\DUST\H817 (DC26)
6	2900131	1	SEAL\GREASE\H817 (SE42)
8	4900053	1	NUT\CASTLE\1-1/4\NF
9	4900114	8	NUT\TAPER\WHEEL\5/8\NF
10	5000065	1	WASH\2.5OD\1.25ID\224
11	2900160	8	STUD\WHL\5/8-18X2-1/2GR8
12	2900129	1	HUB\8-BOLT\w/RACES\w/NUTS
	2900140		HUB\8-BOLT\COMPIH-817

STANDARD DRIVELINE - 3600787

3600787-PTO\255-25002\44E\1-3/4 WWCV

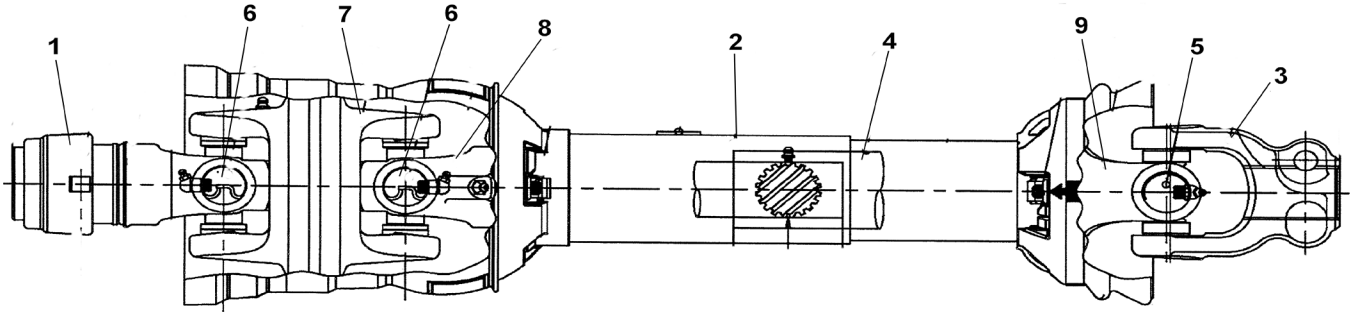

ITEM	PART NO.	DESCRIPTION
1	3600788	JOINT&SHFT\44E\1-3/4 WWCV
2	3600570	GUARD\PTO\FRNT\OUTER
3	3600571	JOINT&TUBE\44E\U\20SPL
4	3600572	GUARD\PTO\REAR\INNER
	3600489	KIT\REP\NYLON\PLSTC;SHLD

STANDARD DRIVELINE - 3600791

ITEM	PART NO.	DESCRIPTION
1	3600792	JOINT&SHFT\44E\1-3/8-21 WWCV
2	3600578	GUARD\PTO\FRNT\OUTER
3	3600579	JOINT&TUBE\44E\U\20SPL
4	3600580	GUARD\PTO\REAR\INNER
	3600489	KIT\REP\NYLON\PLSTC;SHLD

3600791-PTO\255-25000\44E\1-3/8-21 WWCV

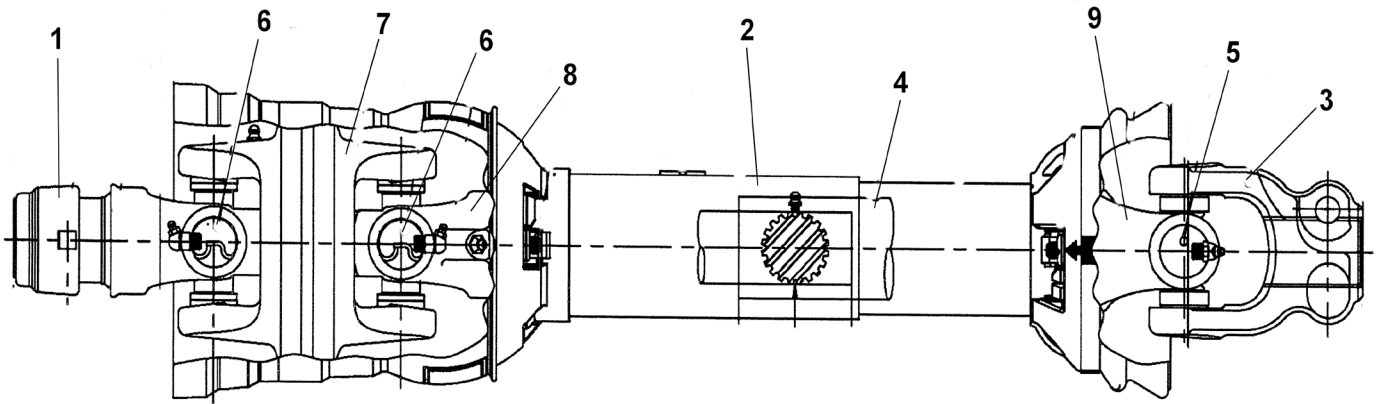

STANDARD DRIVELINE - 3600596

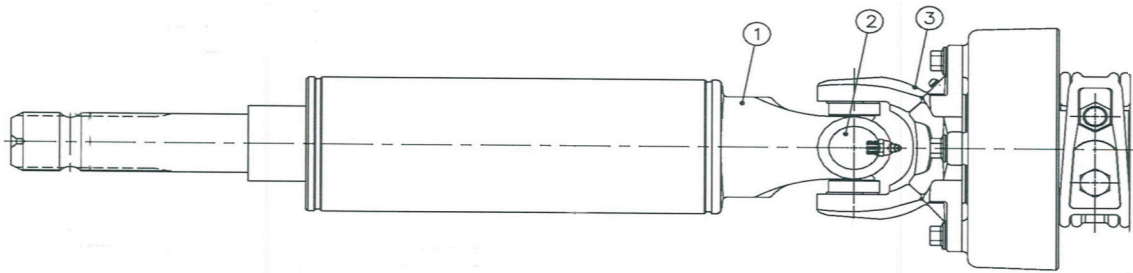

ITEM	QTY.	PART NO.	DESCRIPTION
1	1	3600728	YOKE&TUBE&SPLINDLE\44E\20SPL
2	1	3600604	CROSS&BRG\44E\WSLR
3	1	3600755	YOKE\CLUTCH\AUTO\ASSY\44E\18K

2-SPEED DRIVELINE - 3700783

ITEM	PART NO.	DESCRIPTION
1	3600784	JOINT&SHFT\44E\WWCV\20SPL
2	3600586	GUARD\PTO\FRNT\OUTER
3	3600587	JOINT&TUBE\44E\U\20SPL
4	3600588	GUARD\PTO\REAR\INNER
	3600489	KIT\REP\NYLON\PLSTC;SHLD

3700783-PTO\255-25003\44E\1-3/4 WWCV

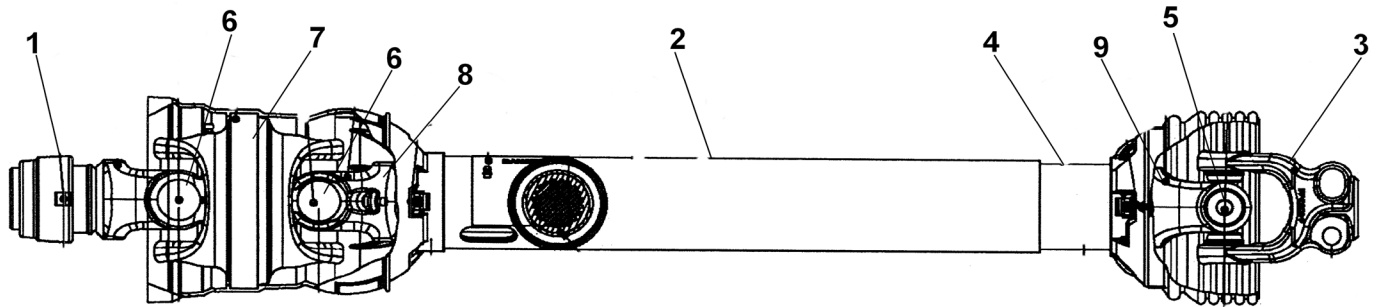

2-SPEED DRIVELINE - 3600785

ITEM	PART NO.	DESCRIPTION
3	3600621	JOINT&TUBE\44E\CV\21SPL
4	3600786	JOINT&SHFT\44E\1-3/8 WWCV
5	3600623	GUARD\PTO\FRNT\OUTER
6	3600624	GUARD\PTO\REAR\INNER
	3600489	KIT\REP\NYLON\PLSTC;SHLD

3600785-PTO\255-25005\44E\1-3/8 WWCV

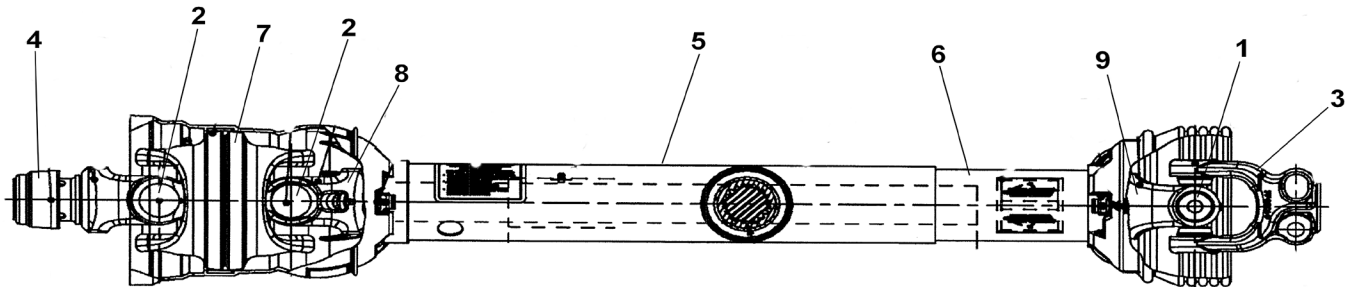

2 SPEED DRIVELINE - 3600819

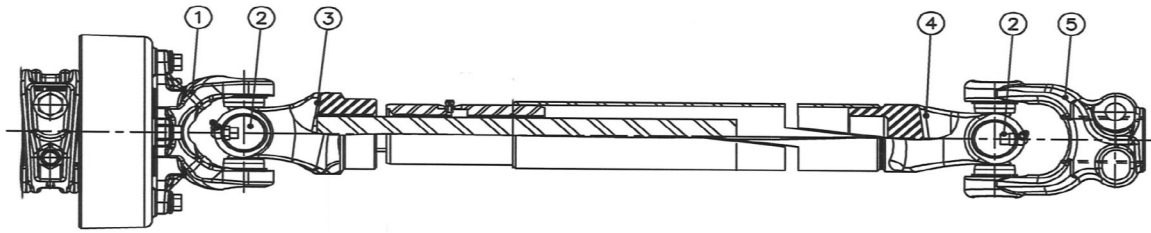

ITEM	QTY	PART NO.	DESCRIPTION
1	1	3600755	YOKE\CLUTCH\AUTO\ASSY\44E\18K
2	2	3600604	CROSS&BRG\44E\WSLR
3	1	3600866	YOKE&SHAFT\44E\20SPL
4	1	3600867	YOKE&TUBE&SLEEVE\44E\20SPL
5	1	3600720	YOKE\44E\20SPL



1.



2.

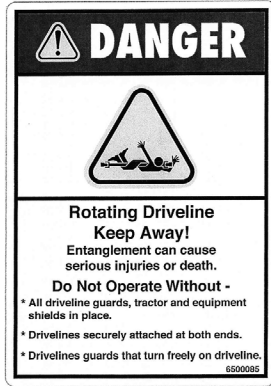

3.

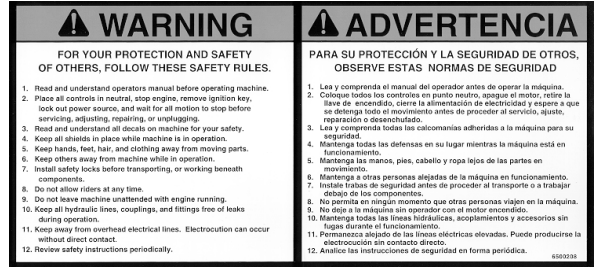

4.



8.



5.

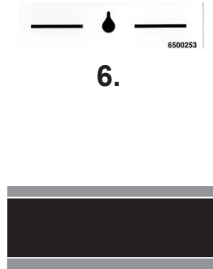

6.



10.

13.

14.



9.



11.

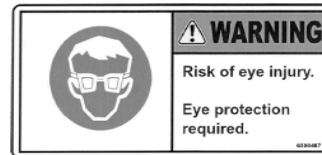

17.

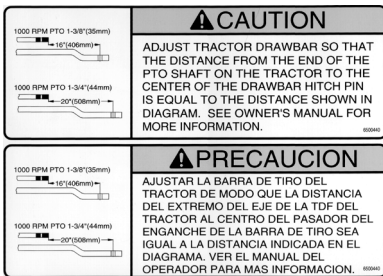

16.



15.

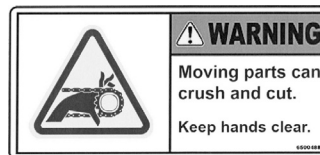

18.

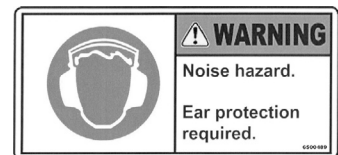

19.



20.

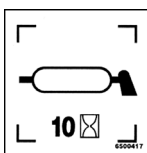

12.

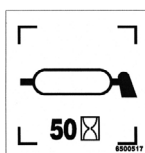

22.



23.



21.

DECALS

ITEM	PART	QTY.	PART DESCRIPTION
1	6500020	2	DECAL\LOGO\HYBSTR\SNBRS\3
2	6500043	1	DECAL\WARN\NO;RIDERS
3	6500085	1	DECAL\DNGR\ROTATING;DR-LNE
4	6500208	1	DECAL\WARN\GENERAL
5	6500220	1	DECAL\WARN\HI;PRESS;FLUID
6	6500253	2	DECAL\INFO\FLUID;LEVEL\
7	6500302	7'-6"	DECAL\LOGO\STRIP\3\RD&BLK
8	6500304	2	DECAL\LOGO\HYBSTR\1-3/4\W/
9	6500339	2	DECAL\WARN\PINCH;POINT
10	6500366	1	DECAL\SMV
11	6500383	2	DECAL\WARN\AUGER\MIXER
12	6500417	1	DECAL\GREASE\10 HRS
13	6500434	2	DECAL\2X9\RED\REFCT
14	6500435	6	DECAL\2X9\AMBER\REFCT
15	6500437	1	DECAL\LOCATOR\DOOR
16	6500440	1	DECAL\CAUT\ADJ_DRWBAR\16&20
17	6500487	1	DECAL\WARN\PPE\EYE
18	6500488	1	DECAL\WARN\PARTS\MOVING
19	6500489	1	DECAL\WARN\PPE\HEARING
20	6500490	1	DECAL\WARN\NO STEP
21	6500507	2	DECAL\LOGO\CMF710
22	6500517	3	DECAL\GREASE\50HRS
23	6500543	1	DECAL\GEARBOX\2SPEED\HNL

6500508

DECAL\KIT\CMF710

7500077	12 OZ	YELLOW SPRAY PAINT
7500092	QUART	YELLOW PAINT
7500091	GALLON	YELLOW PAINT
7500078	12 OZ	RED SPRAY PAINT
7500105	QUART	RED PAINT
7500104	GALLON	RED PAINT

DECAL LOCATIONS

DOGLEG CONVEYOR

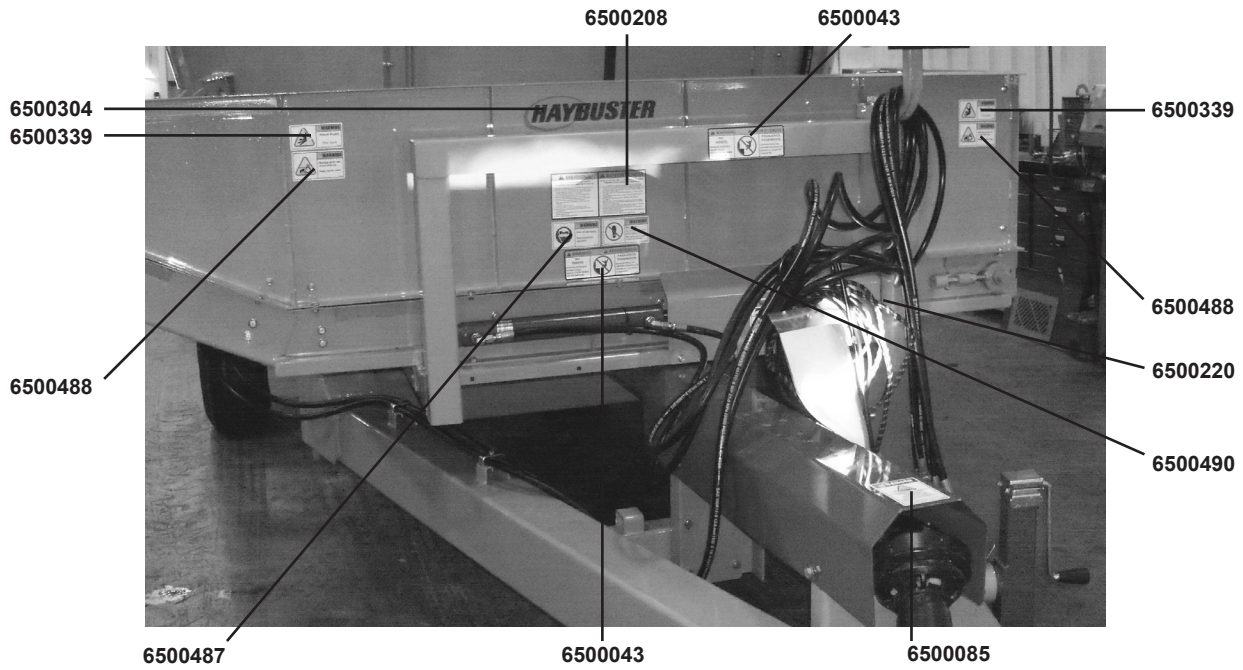

STANDARD CONVEYOR

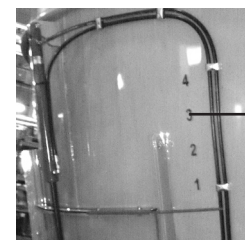
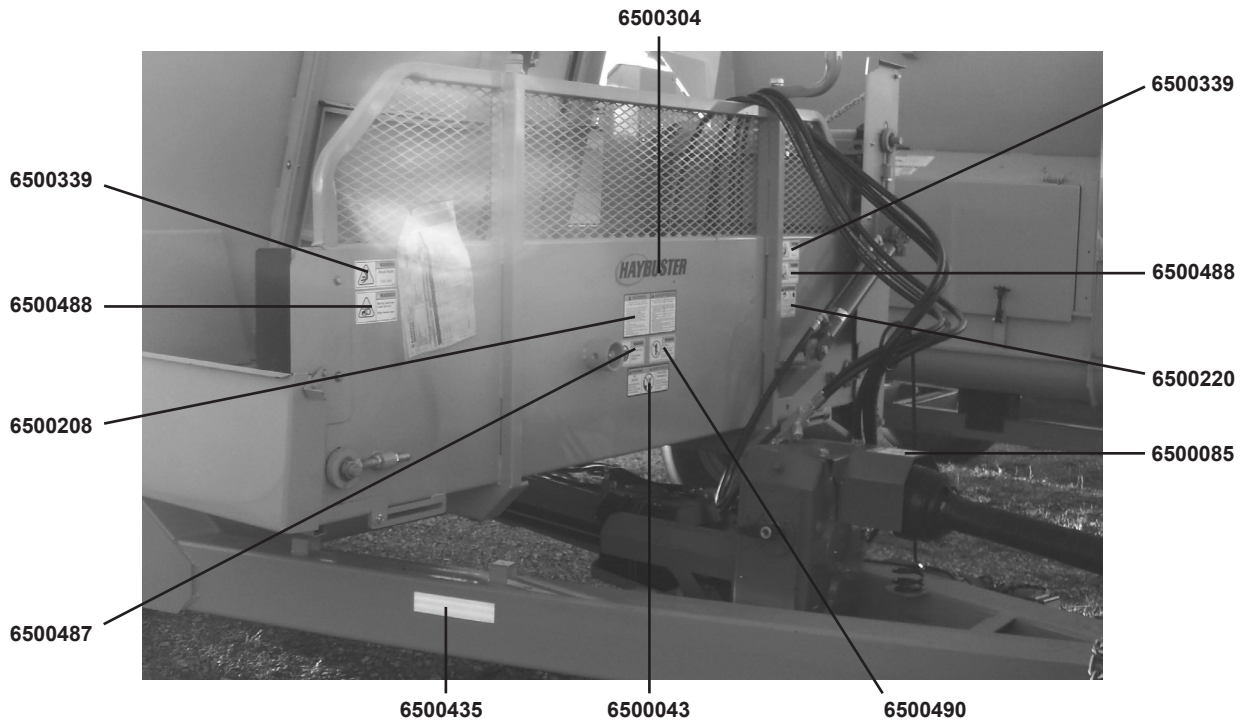

DECAL LOCATIONS

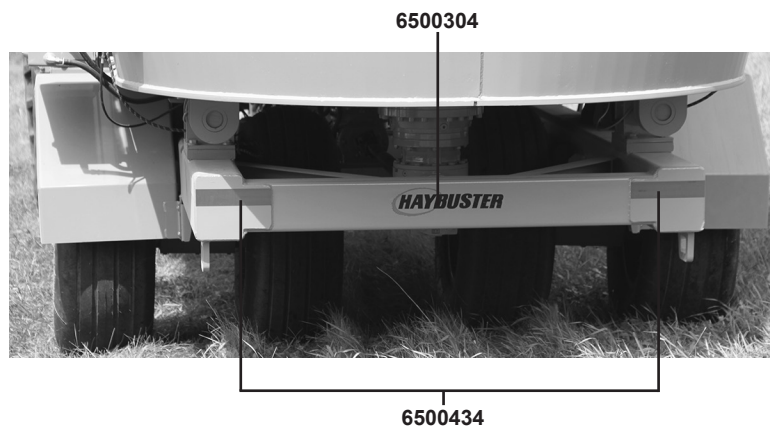
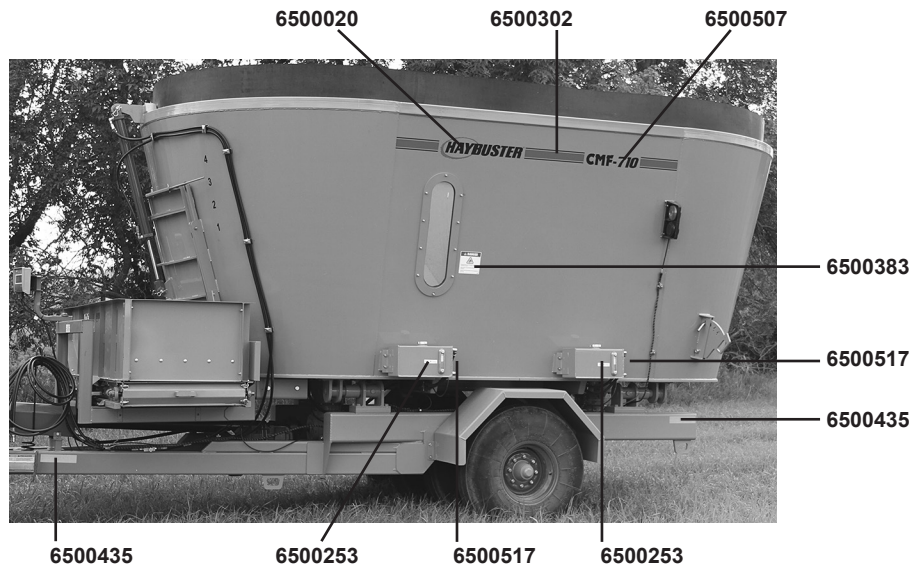

5700713 CMF TAIL LIGHTS

FOR REFERENCE ONLY
1 - GREEN - TAIL OR CLEARANCE
2 - BROWN - BRAKE/AUX
3 - YELLOW - TURN & FLASH
4 - WHITE - GROUND WIRE

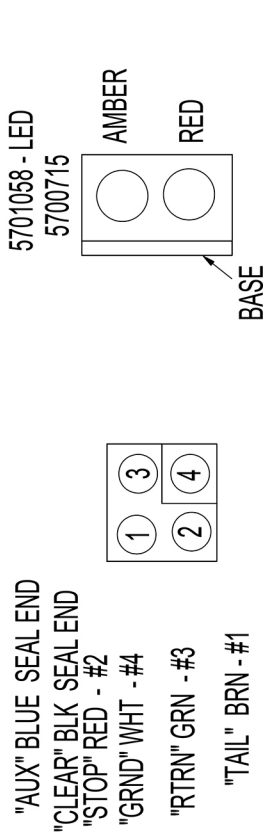

CONNECT THESE TWO WIRES IF NOT USING BATTERY
IF USING BATTERY, DO NOT CONNECT THESE WIRES
"GRND" WHT TO BLACK WIRE IN SCALE WIRING
"STOP" RED TO RED WIRE IN SCALE WIRING

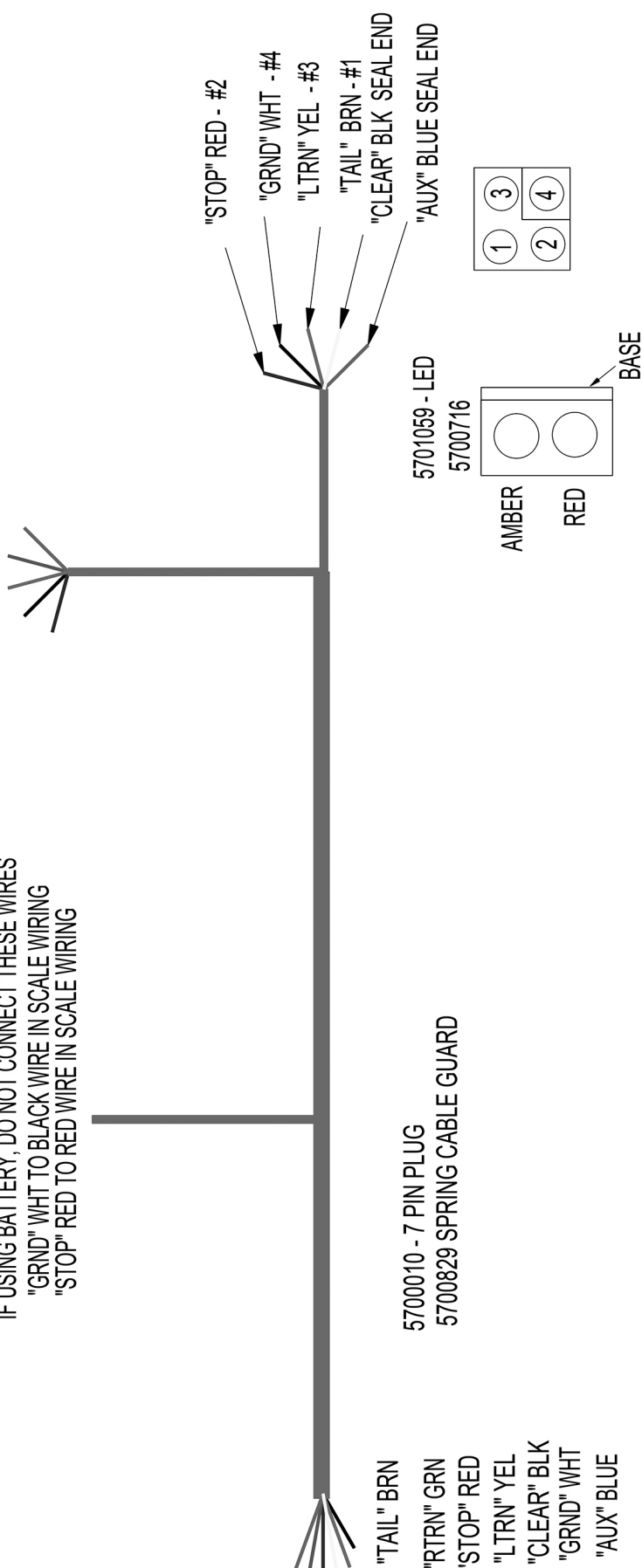

Please fill out the delivery report on the following pages. The white copy is to be returned to:

DuraTech Industries International Inc.
P.O. Box 1940
Jamestown, ND
58402-1940

The yellow copy is the dealer copy; the pink copy is to be retained by the customer.